



548

**Showcase
Merchandiser**

**Field Service Manual
And
Parts Catalog**

Part Number 900-54805 D
Fourth Edition

548 Showcase Merchandiser

Field Service Manual and Parts Catalog

This manual contains all of the necessary information needed to install, operate and perform basic service on the 548 Showcase Merchandiser. The front section contains vendor specifications and a table of contents. The description section reviews the major components of the vendor along with a more detailed discussion on the slide in-slide out refrigeration system. The service mode operation section contains an itemized description of how to program the machine's features. The troubleshooting section contains a preliminary checklist, a power supply light indicator table and two troubleshooting charts and wiring schematics. The parts section has illustrations that call out service and replacement parts for the 548 Showcase Merchandiser.

<p>Part Number 900-54805 D Fourth Edition First Printing March, 1996 Printed in U.S.A.</p>
--

SPECIFICATIONS:

548 Showcase Merchandiser

GENERAL

Depth	35 5/8 in.
Width	41 in.
Height	72 in.
Net Weight	790 lb.
Shipping Weight	840 lb.
Maximum Location Ambient Temperature	110° F

POWER REQUIREMENTS

Voltage	120 VAC	220/240 VAC
Current	16 AMPS	10 AMPS
Frequency	60 HZ	50/60 HZ

VEND CAPACITY

Total Items	154 MAX.
Delivery Doors	11
Delivery Door Dimensions (Nominal)	
9 Doors	4 in Height
2 Doors	5 in Height
11 Doors	6 or 9 in. Width
Compartment Depth (Nominal)	9 1/4 in. Depth
Shelf Configurations Available:	
Over/Under	14 Products Per Shelf
Plain	7 Products Per Shelf
Vertical Split	14 Products Per Shelf
Food Compartment	
Operating Temperatures	38° ± 4° F

COIN MECHANISMS

120V Models-12 or 15 Pin	
MARS	TRC - 6000
COINCO	9300L
24 V Models-15 Pin Only	
MARS	TRC - 6010 - XV
COINCO	9302LF

REFRIGERATION SYSTEM

	<u>120 V</u>	<u>220/240 V</u>
Type	3/4 HP Air Cooled	3/4 HP Air Cooled
Charge	R404a (18oz.)	R404a (510 Grams)
Operating Pressures	@ 75° F	@ 24° C
High Side :	200 - 240 psig	1440-1579 KPA
Low Side :	23 - 25 psig	137-151 KPA
Test Pressures:	300 psig	

CAUTION !

Do not use 24 volt Coin Mech with 12 pin plugs! This will result in permanent damage to the Coin Mech and/or vending machine.

CAUTION !

This system is charged with R404a Refrigerant.

Table Of Contents

Specifications	vi
Coin Mech. Chart	viii
Features	ix

SECTION 1

DESCRIPTION

Introduction	1-1
Major Components	1-1
Refrigeration	1-2
Point of Sale Messages	1-5

SECTION 2

INSTALLATION

Introduction	2-1
Unpacking Instructions	2-1
Set-Up Instructions	2-1
Coin Mech Loading	2-2
Pre-Operation Check	2-3

SECTION 3

SERVICE MODE OPERATION

Introduction	3-1
Blind Operator Feature	3-1
Basic Program Set-Up	3-2
Filling The Turret	3-3
Factory Default Settings	3-4
Quick-Reference Guide	3-5
Mini Menu Flowchart	3-6
Full Menu Flowchart	3-7
Price Menu	3-8
MIS Menu	3-10
Options Menu	3-17
Clock Menu	3-23
Turret Menu	3-24
Auto Price Menu	3-25
Discount Menu	3-27
Diagnostics Menu	3-29
Default Menu	3-30
Blind Operator Feature	3-30

SECTION 4

TROUBLESHOOTING

Check List	4-1
Turret Motor Errors	4-2
Coin Mech Problems	4-2
Initial Power Up	4-3
Power-Up Initialization	4-3
Refrigeration System	4-3
Compressor Circuit Description	4-4
Table 4-1 Component Resistance	4-4
Backup Refrigeration Unit	4-5
Backup Refrigeration Schematic	4-5

Refrigeration System Wiring Diagram (Domestic)	4-6
Refrigeration System Wiring Diagram (European)	4-7
Power Supply Indicator Lights	4-8
Troubleshooting Chart Error Messages	4-10
Troubleshooting Chart Problem / Solution	4-12
Troubleshooting Chart Refrigeration	4-15
System Schematic	4-19
Universal Control Board Schematic	4-21
Power Supply Schematic	4-25
Message Center Display Schematic	4-29

SECTION 5

MAINTENANCE

Introduction	5-1
Adjustments	5-1
Delivery Door Switch	5-1
Lock Bar Switch	5-1
Trans-Motor Interlock Switch	5-2
Repair and Replacement	5-2
Checking Refrigeration System	5-2
Turret Removal	5-3
Delivery Door Removal	5-3
Cleaning	5-3

SECTION 6

PARTS CATALOG

Table of Contents	6-1
Main Door and Trim Panels	6-4
Main Door (Exterior)	6-6
Message Center	6-8
Main Door (Interior)	6-10
Lower Main Door Components	6-12
Coin Mech Compartment	6-14
Door Assembly - Coin Mech Compartment	6-16
Delivery Door Panel Assembly	6-18
Cabinet Final Assembly	6-20
Power Supply Assembly	6-24
Main Panel Switch	6-26
Turret Drive Motor Assembly	6-28
Turret Components - Bottom	6-30
Turret Drive and Roller	6-31
Lock Bar Solenoid	6-32
Refrigeration Unit	6-33
Universal Control Board	6-35
Power Supply Circuit Board Assembly	6-38
Harness List	6-41
European Part Numbers	6-42
Hardware List	6-43

SPECIFICATIONS:

548 Showcase Merchandiser

GENERAL

Depth	35 5/8 in.
Width	41 in.
Height	72 in.
Net Weight	790 lb.
Shipping Weight	840 lb.
Maximum Location Ambient Temperature	110° F

POWER REQUIREMENTS

Voltage	120 VAC	220/240 VAC
Current	16 AMPS	10 AMPS
Frequency	60 HZ	50/60 HZ

VEND CAPACITY

Total Items	154 MAX.
Delivery Doors	11
Delivery Door Dimensions (Nominal)	
9 Doors	4 in Height
2 Doors	5 in Height
11 Doors	6 or 9 in. Width
Compartment Depth (Nominal)	9 1/4 in. Depth
Shelf Configurations Available:	
Over/Under	14 Products Per Shelf
Plain	7 Products Per Shelf
Vertical Split	14 Products Per Shelf
Food Compartment	
Operating Temperatures	38° ± 4° F

COIN MECHANISMS

120V Models-12 or 15 Pin	
MARS	TRC - 6000
COINCO	9300L
24 V Models-15 Pin Only	
MARS	TRC - 6010 - XV
COINCO	9302LF

REFRIGERATION SYSTEM

	<u>120 V</u>	<u>220/240 V</u>
Type	3/4 HP Air Cooled	3/4 HP Air Cooled
Charge	R404a (18oz.)	R404a (510 Grams)
Operating Pressures	@ 75° F	@ 24° C
High Side :	200 - 240 psig	1440-1579 KPA
Low Side :	23 - 25 psig	137-151 KPA
Test Pressures:	300 psig	

CAUTION !

Do not use 24 volt Coin Mech with 12 pin plugs! This will result in permanent damage to the Coin Mech and/or vending machine.

CAUTION !

This system is charged with R404a Refrigerant.

HOW TO USE THIS MANUAL

This manual contains six sections. The front section contains a table of contents, power requirements and operating specifications. Described below is a brief outline of the numbered sections and the information discussed there.

SECTION 1 - DESCRIPTION - Section 1 contains a general introduction to the 548 Showcase Merchandiser. It provides descriptions of the major components and features of the machine and a listing of point of sale messages. Before attempting to unpack or install this vendor, read and familiarize yourself with this section and Section 2 - Installation.

SECTION 2 - INSTALLATION - Section 2 contains unpacking and setup instructions. This section describes how to initialize the machine, load the coin mechanism and perform a pre-operation check. Use this section to install and check out the vendor.

SECTION 3 - PROGRAM OPERATION - Section 3 contains detailed programming information and instructions necessary to perform all of the service mode operations. This section will explain how to enable the functions available on this machine. It provides a detailed explanation of MIS features and operations.

SECTION 4 - TROUBLESHOOTING - Section 4 contains troubleshooting procedures, troubleshooting charts, schematics and wiring diagrams for the entire vendor Main Controller and Refrigeration Unit are also located in this section. Use this section in conjunction with the information in Section 5 - Maintenance, to isolate and repair vendor malfunctions.

SECTION 5 - MAINTENANCE - Section 5 contains instructions for cleaning, adjusting, repairing and replacing components on the 648 Merchandiser. Adjustment, repair and replacement procedures should be performed only as required. Isolate equipment trouble using the information and diagrams in Section 4 before attempting to make adjustments or replace parts. Illustrations detailing the sold out switch actuator adjustment are located in this chapter.

SECTION 6 - PARTS CATALOG - Section 6 contains a view of each assembly with part and section called out. Part numbers under a four digit assembly number are indented to the right if they are shipped as a group when ordering the assembly number. If they are not indented they must be ordered individually.

COIN MECH. CHART

ROWE VENDING MACHINE COIN MECH USAGE													
Coin Acceptors	406				425				448 E2	505	548/ 648	550/ 650	5900
Coinco	6 PUMP		6 PUMP		W.A.D.		W.A.D.						
	WOBA	WBA	WOBA	WBA	W.A.D.	WOBA	WBA	W.A.D.					
9300S <small>Single Price \$12.75 Max 120 VAC</small>	X		X			X							
9340S <small>Single Price \$12.75 Max 120 VAC</small>	X	X	X	X		X	X						
9360S <small>Single Price \$12.75 Max 120 VAC</small>	X	X	X	X		X	X						
S75-9800B-907 <small>Single Price \$3.15 Max 120 VAC</small>	X		X			X							
S75-9400B-977 <small>Single Price \$1.15 Max 120 VAC</small>	X		X			X							
F300E-9210 <small>Four Price \$3.15 Max 120 VAC</small>	3	3	3	3		X	X						
F300-9400 <small>Four Price \$3.15 Max 120 VAC</small>	X		X			X							
S300-9410 <small>Single Price \$3.15 Max 120 VAC</small>	X	X	X	X		X	X						
9300L <small>Microtech 110 VPDC</small>					X			X	X	X	X	X	X
9302LF <small>Microtech 24 VPDC 15 Pin Con.</small>										X	X	X	X
MARS													
Cashflow										X	X	X	X
TRC6010XV <small>Microtech 24 VPDC 15 Pin Con.</small>										X	X	X	X
MC5000 <small>Microtech 117 VPDC \$12.75 Max</small>					X			X	X	X	X	X	X
TRC6000 <small>Microtech 117 VPDC \$12.70 Max</small>					X			X	X	X	X	X	X
TRC6200 <small>120V Single Price \$5.35 Max</small>	X	X	X	X		X	X						
TRC6200H <small>120V Single Price \$5.35 Max</small>	1	4		4			4						
TRC6800 <small>120V Single Price \$10.00 Max</small>	X	X	X	X		X	X						
TRC6800H <small>120V Single Price \$10.00 Max</small>		4		4			4						
MC5802 <small>Single Price 115 VAC</small>	X	X	X	X		X	X						
MC5807 <small>Single Price 115 VAC</small>	X	X	X	X		X	X						
MC5920 <small>Four Price 115 VAC \$5.35 Max</small>	X	2	X	2		X	2						
MC5920H <small>Four Price 115 VAC \$5.35 Max</small>													
MS1600 <small>European 24 VAC 50 Hz</small>									X	X	X	X	X
MS1700 <small>European Tropicalized 24 VAC 50 Hz</small>									X	X	X	X	X
MS1900 <small>European 24 VAC 50 Hz</small>									X	X	X	X	X
NRI <small>National Refractors Inc.</small>													
G-26.4400 <small>European 24 VAC 50 Hz</small>									X	X	X	X	X
Azkoyen													
AN-200										X			X

1= Use with 408-6027 Kit 2= Remove R35 from MC5920 AH when using CBA - 2 B.A. (Also Needs 425-1856 harness)
 3= Needs four price kit 4= B.A. Compatible

548 Features

MESSAGE CENTER

The 548's message center has a 20 character vacuum fluorescent display that can scroll up to 300 characters. It can be programmed to display a custom message or the time and date.

By pressing the following key combinations on the Message Center, the following information can be displayed:

HOT KEYS

<BLANK> <C>	Inside temp. Celsius
<BLANK> <D>	Date and time
<BLANK> <F>	Inside temp. Fahrenheit
<BLANK> <H>	Health control status
<BLANK> <I>	Machine ID number
<BLANK> <K>	*Security Code

*Note: Operates in service mode only.

EASYKEY™ MENU SYSTEM

Programming is simple using four programming keys to navigate through the menus to program the machine:

<UP>	<DOWN>
<SET>	<NEXT>

REAL TIME CLOCK

Keeps track of start and stop times for options and when faults occur.

TURRET LOCKOUT

Up to 6 large sections (12 small sections) can be reserved until a specified time.

RANDOM FREE VEND

The customer can win a free product. Variable odds (1:50 to 1:3000).

DISCOUNTS

Up to three discount schedules can be offered. Each with their own start and stop times by date and time.

PROGRAMMABLE COIN LOADING

Coins can be loaded through the top or side of coin the mech.

MIS(MANAGEMENT INFORMATION SYSTEM)

Keeps track of:

- Sales by shelf
- Sales by product codes
- Number of free vends
- Value of free vends
- Number of random free vends
- Value of random free vends
- Number of discount #1 sales
- Value of discount #1 sales
- Number of discount #2 sales
- Value of discount #2 sales
- Number of discount #3 sales
- Value of discount #3 sales
- Number of schedule #1 vends
- Number of schedule #2 vends
- Number of schedule #3 vends

MIS keeps accurate inventory of money in the Cash Box, Coin Mech, Bill Stacker and Card Credit. It provides resettable and non-resettable sales data.

MULTIVIEW

Rotates the turret 3 sections, every 3 minutes at programmable start and stop times.

NEW TURRET DESIGN

- Can be rotated in either direction.
- Can be easily removed in one piece.
- Removable blower screen at vend door.
- Dynamic non-mechanical brake.

COIN MECHANISM

Can use either 110VDC (12 or 15 pin) or 24VDC (15 pin) Coin mechanisms

NOTE: See Coin Mech Chart page viii.

REFRIGERATION SYSTEM

- Unit easily removable in one piece
- Uses environmental friendly R404a refrigerant.
- Compressor start delayed to prolong compressor lifespan.

OTHER FEATURES

- Debit Card Reader Capability
- Hard Copy Printout Capability
- FIFO or SHOPPER Capability
- Four Shelves for Inside Storage
- Blind Operator Mode

This page intentionally left blank.

Section 1: DESCRIPTION

INTRODUCTION

The 548 Showcase Merchandiser has a maximum capacity of 154 items. It is capable of three level pricing controlled by its own Real Time Clock. Sections of the turret can be locked out of availability until a preset time. The Universal Control Board (UCB) permits individual programming to vend in either the FIFO (First In/First Out) mode or the Shopper mode. For setting prices please refer to page 3-2.

The message center uses point of sale messages to help customers make purchases, while the UCB collects and accumulates MIS (Management Information Systems).

The UCB stores error messages in the event of a system malfunction, which will help to quickly isolate the problem and return the vendor to service. Refer to page 1-5 for Point of Sale messages and page 4-10 for error messages respectively.

MAJOR COMPONENTS

Universal Control Board

The UCB controls and monitors the vendor's performance. Further, it regulates its temperature, stores times and prices, records error messages, accumulates cash totals and interfaces with the message center.

Message Center

Partially seen from the outside of the unit, the message center houses the vacuum fluorescent display, **TURRET ROTATION** keys, **SELECTION** keys, and the **SET, NEXT, UP,** and **DOWN** keys used in programming this unit. These programming keys are used to access the EasyKey™ Menu System described in the Section 3.

Coin Mechanisms

The 548 Showcase Merchandiser provides a 15 Pin Domestic Coin Mechanism Socket. This allows the use of 120 Volt 'Dumb Mechs' with both 12 and 15 pin plugs, and a 24 Volt 'Dumb Mech' with the 15 pin plug.

NOTE:

Do NOT use a 24 Volt Mech with the 12 pin, 120 volt plug. If used, damage to Coin Mech and vendor will occur. (See page viii - Coin Mech Chart - for appropriate Coin Mech use.)

Main Power Switch Assembly

This assembly is located in the bottom left corner of the cabinet. It houses the Main Power ON/OFF switch, along with a switch which opens the refrigeration circuit to prevent frost build up. It also contains two circuit breakers to protect the vendor from a power overload. The vend interlock switch that opens the vend circuit when the door is ajar is located on the inside of the main door near the cash box.

Service Switch

This switch is located in along the edge, on the hinge side, of the Main Door. It is a momentary rocker switch that can be used to single step or continuously rotate the Turret when cleaning and replenishing product.

Shelf Assemblies

A four shelf storage rack is located along the right wall of the cabinet. This rack is intended to store nonperishable precooled products to be used at the next servicing.

Turret

The Turret can be rotated in both directions and programmed to lock out sections until a preset time. Refer to page 3 - 24. At each subsequent power up, the turret will automatically rotate one full revolution to assure proper relationship to the UCB's logic setting.

Electronic Digital Thermometer

The electronic digital thermometer is located on the inside of the main door. This probe is used to monitor the temperature of the cabinet interior for the Universal Control Board, which in turn, controls the unit's Temperature and the Health Control feature.

To read the interior cabinet temperature, press the <BLANK> key on the selection keyboard, followed by the <F> key. The display will show the temperature in degrees Fahrenheit, or press <BLANK> then <C> for the temperature in Celsius.

Health Control

After opening and closing the main door, the compressor has 30 minutes in which to bring the vending compartment temperature down to 45° F.

To display the amount of time remaining in the pulldown period, press the <BLANK> key and then the <H> key. "HEALTH DELAY XX MINS" will appear on the message center.

After the 30 minute pull down period expires, if the <BLANK> key is depressed and then the <H> key is depressed "HEALTH CONTROL ON" will appear on the message center. This indicates that the temperature inside the vending compartment, is being monitored. If the temperature inside the vending compartment rises above 45° F for a one minute period, the machine will go out of service.

To display the time and date the machine went out of service press the <BLANK> key and then the <H> key. "OFF 'TIME' 'DATE'" will be displayed on the message center, where "TIME" and "DATE" are the time and date when the machine went out of service due to a health control error.

To reset a "HEALTH TIME EXPIRED" error, clear the errors and open and shut the main door. Depress the <BLANK> key and then depress the <H> key to display "HEALTH DELAY XX MINS" on the message center. If the message center still displays "OFF 'TIME' 'DATE'", then there is a problem with the main door switch.

REFRIGERATION

Electrical (Domestic)

The self contained refrigeration system is designed to slide in and out of the vendor as one complete assembly. A normal 3 pin AC power cord supplies power to the Compressor, Evaporator Blower, and the Condenser Fan. The evaporator blower runs continuously while AC power is applied, regardless of the temperature inside the machine. The condenser fan runs only when the compressor is running. The compressor and condenser fan are controlled by a relay (P/N 938-8001) located on the power supply chassis.

When the main door is opened, the refrigeration interlock power switch opens, turning off power to the evaporator blower, the compressor and condenser fan. When the main door is closed, the evaporator blower will start immediately but there is a one minute delay before power is applied to the compressor and condenser fan. This delay is used to attain maximum life from the compressor by avoiding rapid ON/OFF cycling.

Health Control Sensor

There is only one temperature probe for both the refrigeration control and the health control. The temperature probe is located on the door at the bottom of the left hand fluorescent lamp reflector.

NOTE:

The compressor control processing runs independently of the health control processing. If the machine goes out of service, the compressor control processing will continue to operate.

The temperature sensor is a solid state temperature measuring device (P/N 548-01818). This temperature sensor converts temperature into a proportional voltage. The Universal Controller Board tracks and displays the temperature of the air and controls the refrigeration and health status. If the temperature probe is disconnected, the temperature reading will go up to 96° F regardless of the true air temperature. Whenever the temperature probe reading is above 80° F the refrigeration control is transferred to the manual backup system. When the temperature falls below 80°, the UCB will again take control of the refrigeration unit. This prevents the machine from becoming too warm if the temperature probe fails. To display the temperature inside the vending compartment, depress the <BLANK> key and then the <F> key. The display will read, "TEMPERATURE = XX F" (BLANK + C = Temperature Celsius)

Compressor Algorithm

The compressor will turn on one minute after closing the main door and will stay on for 20 minutes or until the temperature inside the vending compartment falls below 36° F. If the compressor does not bring the temperature below 36° F within the 20 minute period then the compressor will turn off for a period of two minutes. After two minutes have expired, the compressor will turn back on for another 20 minute period. This 20 minute on and two (2) minute off cycle will continue until the temperature in the vending compartment falls below 36° F.

Once the temperature inside the vending compartment falls below 36° F, the compressor will turn off.

After three minutes, if the temperature inside the vending compartment reaches 40° F the compressor will turn on for at least 80 seconds, but no more than 30 minutes. When the temperature inside the vending compartment falls below 36° F the compressor will turn off for at least 3 minutes.

Vend Cards

The 548 is capable of interfacing with a debit card system without any setup or modifications. The new NAMA MC5000 Interface for Debit Card Systems has been implemented and it is not backward compatible to the old NAMA standards.

If an old NAMA standard debit card system is used, the debit card system will not receive all of the credit signals being used by the 548 and card credit may be lost.

If a Debitek brand debit card system is being used, it is recommended that the system be configured in "Coins to Card Mode". If the "No Coins to Card Mode" is used, there may be discrepancies in the coin MIS displays when credit exists prior to insertion of the card.

The 548 will recognize and support 1 cent credit even though the machine prices are settable in 5 cent increments. Credit acceptance will be disabled once the maximum current machine price is exceeded. Vend card sales information is displayed in the MIS menu and printout. If a vend card is inserted in service mode, the credit transferred can only be viewed in the diagnostic menu. The coin payouts are disabled while vend card credit is established.

Printer

A serial printer may be connected to the UCB to print the MIS information displayed in the MIS Menu. A "PRINTER NOT READY" message will be displayed if a print MIS is attempted and the printer is not connected or off-line.

548 Communication Setting

Baud Rate = 9600 (default)

1200 & 2400 (programmable)

Data Bits = 8

Parity = No

Stop Bit = One

Messages Prior to Credit

SORRY-OUT OF SERVICE This message will appear whenever there is an error condition logged by the software. The display lamps will be out when one or more error conditions exist.

INSERT MONEY This message appears when a Bill Validator is configured and there is sufficient change in the Coin Mechanism.

EXACT CHANGE PLEASE This message appears whenever there is insufficient change in the Coin Mechanism. Users can buy with an over credit and the machine will try to make the correct change.

COINS ONLY PLEASE This message appears only when a Bill Validator is not configured and there is sufficient change.

MAKE FREE SELECTION Machine is in Free Vend. No money is required.

HEALTH CONTROL ON 30 Minute Health Delay expired. Depress <BLANK> Key and then the <H> Key.

ONE MOMENT PLEASE Machine is locating zero position.

11.59PM SUN 12/31/91 Depress <BLANK> Key and then <D> Key. Time - Day of Week - Date.

TEMPERATURE 36° F Depress the <BLANK> Key and then <F> Key. Displays current temperature of Vend Compartment.

TEMPERATURE 4° C Depress the <BLANK> Key and then <C> Key. Displays current temperature of Vend Compartment.

HEALTH DELAY 30 MINS Time remaining during 30 Minute Health Delay, Depress the <BLANK> Key and then the <H> Key.

MAIN DOOR IS OPEN Attempt is made to turn the turret with the keypad when the main door is open.

CLOSE ALL VEND DOORS This message appears when an attempt is made to rotate the turret and the UCB side of the motor interlock switch is open and a delivery door switch is not closed.

Credit Messages

CREDIT - \$ 1.25 Purchaser's current credit, validated by the Coin Mech and/or Bill Validator.

Selection Messages

ITEM IS NOT AT DOOR Turret is positioned for 1/2 compartment vend, when attempting to open a full compartment.

INSUFFICIENT CREDIT Not enough credit to purchase item.

MUST MAKE SELECTION <Coin Return> depressed when vendor has Forced Vend Option in use.

PRESS SELECTOR KEY J Vend attempted at FIFO Door. User must press the <Selector> key corresponding to the desired shelf.

SHELF J NOW READY FIFO Shelf has been positioned to vend.

DOOR D IS OPEN Delivery Door D is open.

YOU ARE A WINNER Random Free Vend Option is on. Customer receives Free Vend.

CAN'T MAKE CHANGE Prohibit Overbuy Option is on, correct change unavailable for vend selected. Forced Vend must be OFF.

ITEM PREVIOUSLY SOLD This message appears when a vend door with a previously purchased compartment is attempted to be opened.

RESERVED SECTION Turret Delay is in use. Can not vend from that section.

OPEN On Column Display when a vend door is open.

Vend Completed

THANK YOU Transaction has been completed successfully.

SOLD On Column Display when an item has been sold.

POINT OF SALES MESSAGES

ENGLISH

THANK YOU
 CREDIT - \$ 1.25
 COINS ONLY PLEASE
 INSERT MONEY
 OPEN
 EXACT CHANGE PLEASE
 KEY D
 SHELF J NOW READY
 MAKE FREE SELECTION
 HEALTH CONTROL ON
 ITEM PREVIOUSLY SOLD
 INSUFFICIENT CREDIT
 MUST MAKE SELECTION
 SORRY-OUT OF SERVICE
 RESERVED SECTION
 ITEM IS NOT AT DOOR
 YOU ARE A WINNER
 CAN'T MAKE CHANGE
 ONE MOMENT PLEASE
 11.59PM SUN 12/31/91
 11.59PM MON 12/31/91
 11.59PM TUE 12/31/91
 11.59PM WED 12/31/91
 11.59PM THU 12/31/91
 11.59PM FRI 12/31/91
 11.59PM SAT 12/31/91
 TEMPERATURE 36 F
 TEMPERATURE 7 C
 HEALTH DELAY 30 MINS
 SOLD
 MACHINE I.D. _____
 CLOSE ALL VEND DOORS

FRENCH

MERCI
 CREDIT - \$ 1.25
 PIECES SEULEMENT SVP
 INTRODUIRE PIECES
 PORTE OUVERTE
 MONTANT EXACT SVP
 APPUYER LA TOUCHE D
 PLATEAU J PRET
 SELECTION GRATUITE
 CONTROLE EN COURS
 ARTICLE VENDU
 MONNAIE INSUFFISANTE
 DOIT FAIRE UN CHOIX
 HORS SERVICE
 SECTION RESERVEE
 ARTICLE NON-ALIGNE
 VOUS AVEZ GAGNE
 CAN'T MAKE CHANGE
 UN MOMENT SVP
 11.59PM DIM 12/31/91
 11.59PM LUN 12/31/91
 11.59PM MAR 12/31/91
 11.59PM MER 12/31/91
 11.59PM JEU 12/31/91
 11.59PM VEN 12/31/91
 11.59PM SAM 12/31/91
 TEMPERATURE 36 F
 TEMPERATURE 7 C
 DELAI DE TEMP 30 MIN
 SOLD
 MACHINE I.D. _____
 CLOSE ALL VEND DOORS

SPANISH

GRACIAS
 CREDITO - \$ 1.25
 SOLO MONEDAS
 INTRODUCZA MONEDASDOOR A IS
 PUERTA A ABIERTA
 CAMBIO EXACTOPRESS SELECTOR
 SELECCIONE TECLA D
 REPISA J PREPARADA
 SELECCIONE
 REVISANDO PRODUCTO
 ARTICULOS AGOTADOS
 CREDITO INSUFICIENTE
 SELECCIONE OPCION
 FUERA DE SERVICIO
 PRODUCTO ELEGIDO
 ARTICULO AGOTADO
 HAS GANADO
 CAN'T MAKE CHANGE
 UN MOMENTO POR FAVOR
 11.59PM DOM 12/31/91
 11.59PM LUN 12/31/91
 11.59PM MAR 12/31/91
 11.59PM MIE 12/31/91
 11.59PM JUE 12/31/91
 11.59PM VIE 12/31/91
 11.59PM SAB 12/31/91
 TEMPERATURA 36 F
 TEMPERATURA 7 C
 REVISION 30 MINS
 SOLD
 MACHINE I.D. _____
 CLOSE ALL VEND DOORS

TABLE 1 - 1 POINT OF SALES MESSAGE

This page intentionally left blank.

Section 2

INSTALLATION

INTRODUCTION

This section contains instructions for unpacking the 548 Showcase Merchandiser and installing it on location. Installation is quick and easily accomplished.

UNPACKING INSTRUCTIONS

The merchandiser is shipped in one carton with all major assemblies in place, ready for installation. The shipping carton should be opened carefully to prevent the merchandiser from being scratched or damaged. Inspect the exterior and interior of the cabinet for evidence of damage. If evidence of damage exists, notify the delivering carrier at once to examine the vendor regardless of the external condition of the carton. Under U.S. regulations, damage claims must be collected from the consignee. Do not return shipping-damaged merchandise until after your claim has been established. Once your claim has been established, damaged merchandise may be returned to an authorized distributor for repair. The invoice for repair charges may then be collected from the carrier. Do not destroy packing material or boxes until the carrier's agent has examined them.

CAUTION !

Pushing or sliding the merchandiser (by hand) on the floor can result in considerable damage to the machine and/or personal injury. Always use appropriate material handling equipment and adequate protective padding to protect the merchandiser.

SET-UP INSTRUCTIONS

1. Place the unit in a well ventilated location with a minimum of **SIX INCHES** between unit and back wall.
2. Remove all tape and packing material from cabinet.
3. The unit must be leveled. Perform level adjustment by using the following illustration:

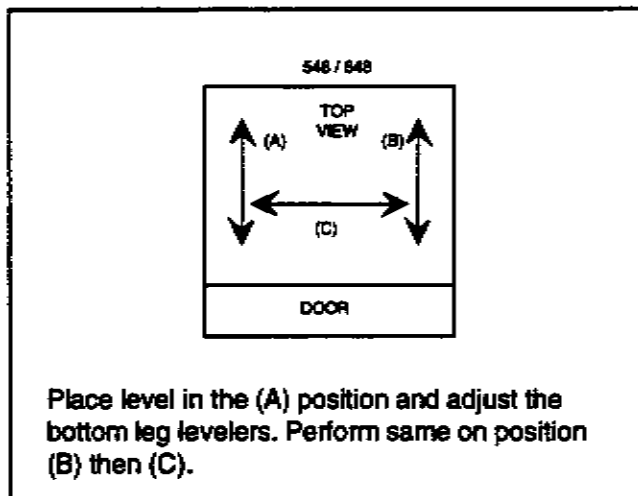

Figure 2-1. Level Adjustment

CAUTION !

If unit is not leveled correctly the refrigerator evaporator may freeze up, causing unit shutdown.

4. Ensure that circuit breakers are firmly in place and that fluorescent lamps are secure in their sockets.
5. Ensure that the Main Power Switch is in the OFF position.
6. Plug the line cord into a dedicated, positively grounded receptacle, capable of delivering the required power as stated on page vi.

7. Install a recommended Coin Mech (See Specification Sheet page viii).
 - a) Check coin chute alignment.
 - b) Check coin return lever operation.
 - c) Adjust if necessary.
8. Install letter labels (Enclosed in plastic envelope) in the corresponding vend doors. ("A" on top to "K" on bottom).
9. Check and insure that all electrical connections are seated properly, especially at the circuit boards.
10. Turn the Main Power Switch ON.
11. Upon Power-up the following sequence of displays should occur:
 - A. The Lock Bar Solenoid energizes.
 - B. The Price Display Boards shall read from top to bottom:

a. "11111"	b. "99.95"	"599.95"
"22222"	"99.95"	"599.95"
"33333"	"99.95"	"599.95"
"44444"	"99.95"	"599.95"
"55555"	"99.95"	"599.95"
"66666"	{THEN} "99.95" OR	"599.95"
"77777"	"99.95"	"599.95"
"99999"	"99.95"	"599.95"
"AAAAA"	"99.95"	"599.95"
"BBBBB"	"99.95"	"599.95"
"CCCC"	"99.95"	"599.95"
 - C. The Message Center should display:
 - a. "KEYPAD-DISPLAY VX.X"
(X.X = latest version of Message Center Display)
 {Then}
 - b. "ROWE 648/548 VX.X"
(X.X = latest revision EPROM on UCB)
 {Then}
 - c. "SERVICE MENU" or "ERROR MESSAGE"
12. Check that all Fluorescent lamps are illuminated.
13. Ensure that the following LEDs on the Universal Control Board are illuminated:

+5 VDC	(Logic Voltage)
VFD	(Vacuum Fluorescent Display Voltage)
- VSRC (Device Source voltage)
- TEST *Blinking* (Control Board Operating Heartbeat)
14. Check the service switch operation by rotating the Turret one full rotation. (See page 6 - 10 (item 11) of Parts Section for location of switch)
15. Perform a full initialization to program the machine to factory default settings.
 - A. In the Service Mode depress the <NEXT> key until the Message Center displays "DEFAULT MENU"
 - B. Depress the <SET> key; "MACHINE INIT - NONE" displays.
 - C. Depress the <UP> key until "MACHINE INIT - FULL" displays.
 - D. Depress the <SET> key; "TURN UNTIL ZERO POS" or "SERVICE MENU" displays.
 - E. With the outside transport switch, rotate the turret until "SERVICE MENU" displays.

NOTE:

Main Door must be closed or "Main Door is Open" Message will be generated.

COIN MECH LOADING

16. This unit must be set up for total cash accountability to operate correctly. You may use one of these two methods to load the coin mechanism.
 - A. In the Service Mode (with coin mech door open) all coin denominations may be loaded through the top flight deck of the coin mech.
 - B. Programming Method: You must keep count and load all the coin denominations through the side loading tubes. In the coin level of the MIS MENU section, the inserted amounts can be keyed into the program. (Refer to page 3-10 of the MIS MENU Section, and perform detailed instructions in the Set Coin Tubes section).

PRE-OPERATION CHECK

1. Perform the Basic Program Set-up routine located in the Service Mode Operation, Section - 3.
2. Close all machine doors. "INSERT MONEY" or other vending mode messages should display if all parameters were set correctly and no errors exist (See Point of Sale Messages Table 1-1, page 1-5.)
3. Rotate the turret one full revolution to the left with transport rocker switch.
4. Rotate the turret one full revolution to the right with transport rocker switch.
5. Insert Coins (5¢, 10¢, 25¢) and make a vend.
6. Check and verify the coin return amount.
7. (If equipped with Bill Acceptor) Insert bill(s). Make a vend.
8. Check and verify the coin return amount.
9. Test vend each door, rotating the turret one space between vends.
10. Close and latch the main door to reset electronic count down timer. The vendor now has 30 minutes to reach 45° F (7.2° C) interior cabinet temperature. The vending circuit will be interrupted by the UCB if temperature requirement is not satisfied, placing the machine out of service.

NOTE:

On initial start up in high ambient temperature it is normal to experience a shut down after the first 30 minutes. Simply open the coin mech door and clear the "Health Time Expired" error. Open and then re-shut the main door (This resets 30 minute health timer). No further shutdown should occur.

11. Unit is now ready.

This page intentionally left blank.

Section 3

SERVICE MODE

INTRODUCTION

The Universal Control Board uses a menu driven interface to configure the merchandiser, choose from available options, access the MIS information, and troubleshoot the merchandiser. Opening the Coin Mech compartment door will automatically bring you into the **SERVICE MENU**. There are nine menu items which are available for programming and/or servicing the 548 Showcase Merchandiser. The message center has ten service keys, four of which are used to access the Easy Key™ Menu System. All messages that will appear on the display will be shown in all upper case letters enclosed with quotation marks.

To move from one menu to another menu, press the **<NEXT>** key. To scroll through the options within that menu, press the **<SET>** key. The first attribute of each option will be displayed. The value or setting of that option may be changed by using the **<UP>** or **<DOWN>** keys. Pressing the **<SET>** key will move to the next option within the menu. Pressing the **<NEXT>** key will move to the next menu.

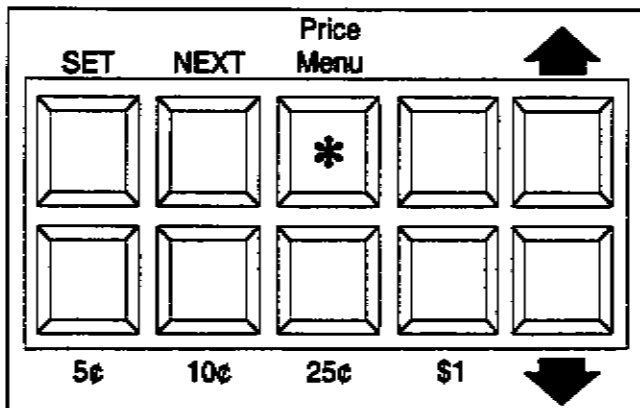

Figure 3-1. Keypad

The **<5c>**, **<10c>**, and **<25c>** keys are used to dispense coins from the coin mech. The **<\$1>** key will be used for the dollar coin when it becomes available.

ERROR MESSAGES

When the coin mech door is opened, the display will show ****** SERVICE MENU ******. If there were any error conditions recorded since the last time the door was opened, the display will show **"ERROR MESSAGES"**.

Press the **<SET>** key and the display will list the error(s) that have been recorded. Continue pressing the **<SET>** key to see all the errors. After all error messages have been shown, the display will show **"CLEAR ERRORS - NO"**. Use the **<UP>** or **<DOWN>** key to select **"YES"** or **"NO"**, then press the **<SET>** key.

If you select **"NO"**, the errors will still be logged the next time the coin mech door is opened.

Note:

If you select **"YES"**, all the error messages will be cleared. This does not correct any problems. It only clears the messages.

If you do not want to see each individual error message press the key to display **"CLEAR ERRORS - NO"**. Use the or keys to select **"YES"**, then press the key.

BLIND OPERATOR FEATURE

When dip switch #1 is set to **ON** the Price Menu key (indicated by the asterisk in the illustration at left) becomes a price menu key for blind operators.

BASIC PROGRAM SET-UP

This section covers a quick set-up for customers not interested in utilizing special features.

Open the Coin Mech Door to display and enter the "SERVICE MODE".

If "ERROR MESSAGE" displays, refer to the Troubleshooting Section of the manual for correction.

1. SET PRICE

Perform the following:

<u>Depress Key</u>	<u>Displays</u>
A. <NEXT>	"PRICE MENU"
B. <SET>	"PRICE SCHED - 1 ACTIVE"
C. <SET>	"SET PRICE 1 - \$X.XX"
D. <UP> or <DOWN>	"SET PRICE 1 - \$X.50"

Upon setting the desired price (Step D), click applicable vend door(s) to the right for this price setting. Repeat Step D for different prices.

2. COIN MECH

Load all coin denominations through the coin mech's top flight deck

NOTE:

If coins are loaded through the side tubes, there is no accountability unless the amount inserted is programmed in the MIS Menu.

3. SET SHELF SIZE

Perform following:

<u>Depress Key</u>	<u>Displays</u>
A. <SET>	"SHELF SIZE - HALF"
B. <UP> or <DOWN>	"SHELF SIZE - FULL"

Toggle (Step B) to desired shelf size and click applicable vend door(s) to the right.

4. SET SHOPPER/FIRST IN FIRST OUT

Perform following:

<u>Depress Key</u>	<u>Displays</u>
A. <SET>	"VENDMODE - SHOP"
B. <Up> or <DOWN>	"VEND MODE - FIFO"

Toggle (Step B) to desired shelf mode and click applicable vend door(s) to the right.

5. ENABLE BILL ACCEPTOR

If unit is equipped with Bill Acceptor, perform the following:

- A. Depress the <NEXT> key until "OPTION MENU" displays.
- B. Depress the <SET> key until "BILL ACCEPTOR OFF" displays.
- C. Depress <UP> or <DOWN> key to toggle Bill Acceptor Enable to OFF or ON, then press the <SET> key.
- D. Depress the <NEXT> key to exit OPTION MENU.
- E. Repeat steps B, C & D for \$1 Accept / Reject, \$2 Accept/Reject and \$5 Accept / Reject.

Security Code

If the Security Code feature is enabled, the display will show "SECURITY CODE - ****". Use the <UP> or <DOWN> keys to display the first character in the security code. When the first character is displayed, press the <SET> key. Continue this procedure for the remaining characters in the security code.

After entering the correct security code and pressing the <SET> key for the last character, the message center will display, "FULL ACCESS GRANTED".

If the security code is unknown the operator may press the <NEXT> key which will enable him to have access to the PRICE, MIS, AUTO PRICE, and DIAGNOSTIC menus.

NOTE:

If the operator has enabled the security feature, selected menus will not be accessible without entering the security code. DO NOT lose the security code.

Sold Out Check Feature

This feature is used to verify if a compartment has been refilled with tampered food.

When the coin mech door is opened, the display will show "*** SERVICE MENU ***". When the sold out feature is enabled and if no error conditions exist, the display will show "CHECK SOLD OUT DOORS".

The price display at each door will show "SOLD" if that compartment should be empty. Open the compartment door and the display will show "NONE". If there is product in a compartment that says "SOLD", discard it. Rotate the turret with the outside transport switch and check the compartments that say "SOLD". Once all the compartments have been cleared, the machine will automatically go into the Service Mode and the display will show "***SERVICE MENU***".

FILLING THE TURRET

Since the Universal Control Board keeps track of the compartment states, it needs to be notified when the machine is being filled. If the main door is opened and the service switch is turned on without touching any message center keys in between, the 548 assumes it is being filled and a "FILLING MACHINE" message is displayed and all compartment solds are reset. If any key is touched before turning on the service switch, the machine assumes it is being serviced, and a "SERVICING MACHINE" message is displayed and the compartment states remain unchanged.

Exact Change Mode

The 548 is in exact change mode and "EXACT CHANGE ONLY" will be displayed on the message center, unless one of the following conditions is met.

1. 2 dimes and a nickel, or 5 nickels are in the coin tubes, then "COINS ONLY PLEASE" will be displayed on the message center (when B/A is disabled).
2. If the bill acceptor is enabled and 3 quarters 2 dimes and a nickel, or 3 quarters and 5 nickels are in the coin tubes, then "INSERT MONEY" will be displayed on the message center.

**Table 3-1
Factory Default Settings**

The following program settings are factory default settings and will be obtained upon operation of the DEFAULT MENU / INITIALIZE FULL routine.

Price Menu		RAND VENDS -	0	Discount Menu	
PRICE SCHED - 1	ACTIVE	FREE VENDS -	0	SET DISCOUNT 1 -	NO
(Price Display all 99.95)		DISC 1 VENDS -	0	SET DISCOUNT 2 -	NO
PRICE SCHED - 2	ACTIVE	DISC 2 VENDS -	0	SET DISCOUNT 3 -	NO
(Price Display .05 through .55)		DISC 3 VENDS -	0		
PRICE SCHED - 3	ACTIVE	MIS CLEAR COUNT -	X *	Diagnostic Menu	
(Price Display .60 through 1.10)		POWER LOSSES -	NO *	HEALTH TEST -	NO
SET PRICE 1 - \$.50	(5n to \$99.95)	PRICE CHANGED -	NO *	CARD CREDIT -	\$.00
SHELF SIZE - HALF	(FULL)	OUT OF SERVICE -	NO *	ZERO POS -	NO
SET VEND MODE - SHOP	(FIFO)	TIME OVER HEALTH -	NO		
MULTICODES - OFF	(ON)	MAX TEMPERATURE -	NO	Default Menu	
SET PROD CODE - 0	(0 to 99)	MIN TEMPERATURE -	NO	MACHINE INIT -	NONE
		CLOCK CHANGES -	0 *	PRINT BAUD RATE -	9600
MIS Menu		Options Menu			
SET COIN TUBES -	NONE	MULTIVIEW -	OFF		
BILL ACPT EMPTY -	NO	FORCED VEND -	OFF		
CASH BOX EMPTY -	NO	BILL ACCEPTOR -	OFF		
PRINT MIS DATA -	NO	SOLD OUT CHECK -	OFF		
CLEAR MIS DATA -	NO	FREE VEND -	OFF		
SALES (R) -	\$.00	RNDM FREE VEND -	OFF		
SALES (N) -	\$.00 *	DISPLAY TIME -	OFF		
BAG TOTAL -	\$.00	SET MACHINE ID -	NO		
CASHBOX -	\$.00	SECURITY CODE -	OFF		
CARD SALES -	\$.00	SET MESSAGE -	OFF		
BILL TOTALS -	\$.00	COLUMN DISPLAY -	SOLD		
ONES -	\$.00	PROHIBIT VENDING -	NO		
TWOS -	\$.00	LANGUAGE -	ENGLISH		
FIVES - \$.00		PROHIBIT OVERBUY -	NO		
COIN TOTALS -	\$.00				
\$1 COINS -	\$.00	Clock Menu *			
QUARTERS -	\$.00	DATE -	1/17/92		
DIMES -	\$.00	SET TIME -	NO		
NICKELS -	\$.00	TIME -	11.32		
RAND VEND -	\$.00	SET TIME -	NO		
FREE VEND	\$.00				
DISC 1 -	\$.00	Turret Menu			
DISC 2 -	\$.00	TURRET DELAY -	OFF		
DISC 3 -	\$.00				
TOTAL VENDS -	0	Auto Price Menu			
SCHED 1 VENDS -	0	ENABLE SCHED 2 -	NO		
SCHED 2 VENDS -	0	ENABLE SCHED 3 -	NO		
SCHED 3 VENDS -	0				
VENDS PER SHELF -	0				

* Denotes Non-resettable Values

QUICK-REFERENCE GUIDE

To check inside cabinet temperature (without opening Coin Mech. Door):

1. Press <Blank> key on keypad
2. Press <F> key (F is for Fahrenheit)
3. Press <C> key (C is for Celsius)

To check Health Control time delay (without opening Coin Mech. Door):

1. Press <Blank> key on keypad
2. Press <H> key (H is for Health Control Status and for time left in initial 30 min. health delay check).

To check Machine ID:

1. Press <Blank> then I key.

To set prices:

1. Press <NEXT> key on Message Center to reach (PRICE MENU)
2. Press <SET> key to reach (PRICE 0.00)
3. Change price shown by using <up> or <down> keys
4. Toggle doors you wish to change to that price

To payout change from coin mech (manually):

1. Press coin switch (5¢, 10¢, or 25¢) on Message center.

To extract MIS data:

1. Press <NEXT> key on Message Center to reach (MIS MENU)
2. Press <SET> to advance through each MIS category
3. (SALES <N>) is Non-resettable (cumulative) cash meter
4. (SALES <R>) is Resettable cash meter

To print MIS data:

1. Connect compatible printer using proper interface cable
2. Press <NEXT> key on Message Center to reach (MIS MENU)
3. Press <SET> key to reach (PRINT MIS DATA -NO)
4. Press <UP> or <DOWN> key to select (PRINT MIS DATA -YES)
5. Press <SET> key to automatically print data

To clear SOLD-out doors:

1. Open Main Cabinet Door. (Do NOT press keys on Message Center)
2. Rotate turret with Service Switch, not outside switches

To clear an error (if lights go out, but prices remain lit):

1. Error descriptions will appear when the coin mech door is opened
2. Press the <SET> key each time an error message displays.
3. (CLEAR ERRORS -NO) will appear
4. Press <UP> or <DOWN> key to select (CLEAR ERRORS -YES)
5. Press <SET> key again, to clear the error

NOTE:

If the recorded error is a Health Time Expired error, the error must be cleared, then the main door must be opened and shut again to reset. It will now have 30 minutes to cool down.

If the recorded error is a Main Door Open error, make sure the main door is securely latched before attempting to clear the error.

Table 3-2. Miscellaneous Information

Maximum price:	\$99.95
Number of price schedules:	3
Number of discounts:	3
Maximum product code:	99
Free vend odds range:	50-3000
Maximum scrollable message length:	300 chars
Maximum fixed message length:	20 chars
Maximum machine ID length:	12 chars
Maximum security code length:	4 chars
Multiview time period:	3 minutes
Compressor turn on temperature:	40 degrees F
Compressor turn off temperature:	34 degrees F
Compressor minimum on time:	80 seconds
Compressor minimum off time:	3 minutes
Maximum health control temperature:	45 degrees F
Maximum time over health control temperature:	5 minutes
Health Control pull down delay:	30 minutes
Health test delay time:	20 seconds

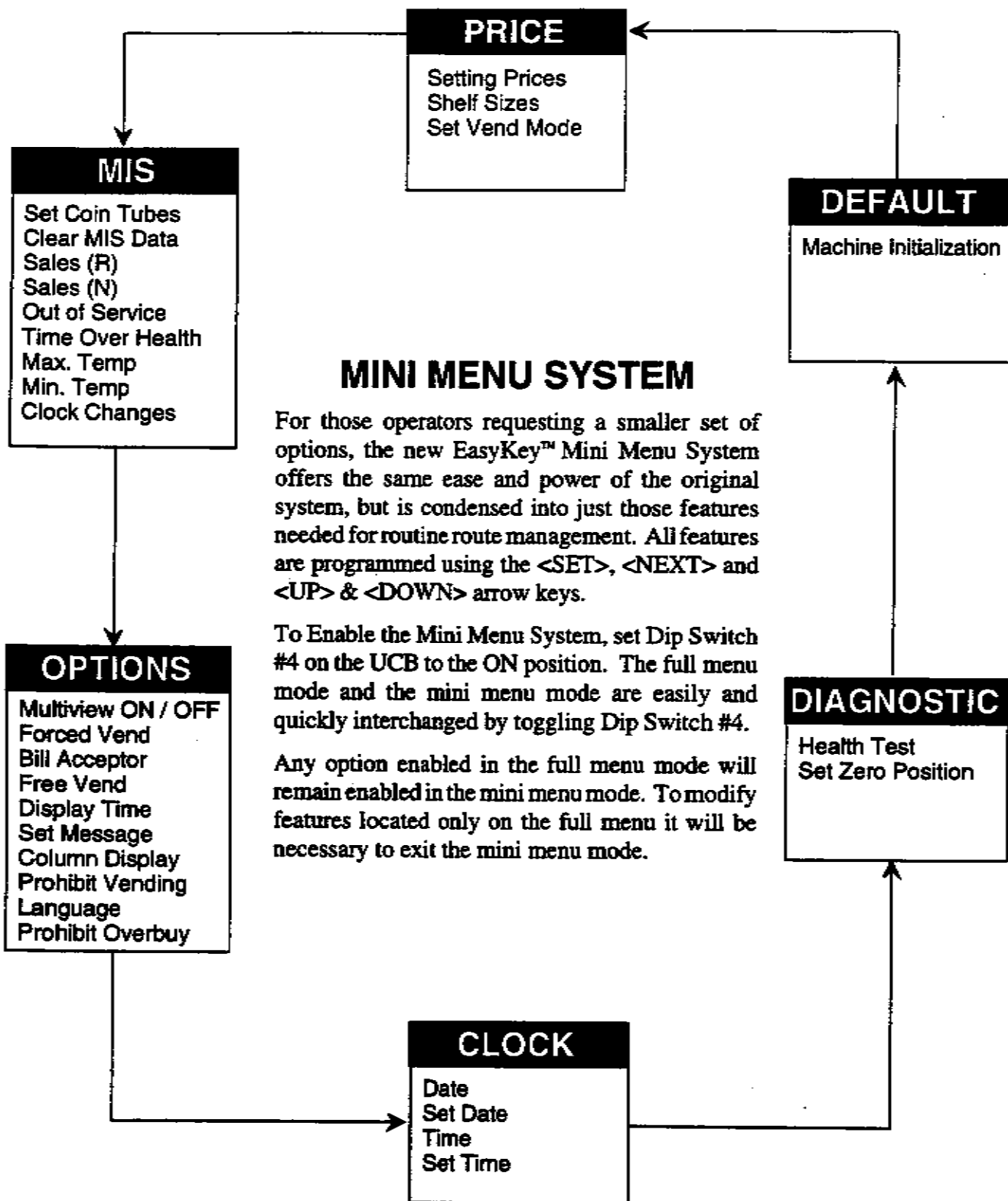

MINI MENU SYSTEM

For those operators requesting a smaller set of options, the new EasyKey™ Mini Menu System offers the same ease and power of the original system, but is condensed into just those features needed for routine route management. All features are programmed using the <SET>, <NEXT> and <UP> & <DOWN> arrow keys.

To Enable the Mini Menu System, set Dip Switch #4 on the UCB to the ON position. The full menu mode and the mini menu mode are easily and quickly interchanged by toggling Dip Switch #4.

Any option enabled in the full menu mode will remain enabled in the mini menu mode. To modify features located only on the full menu it will be necessary to exit the mini menu mode.

Figure 3-2. Mini Menu System

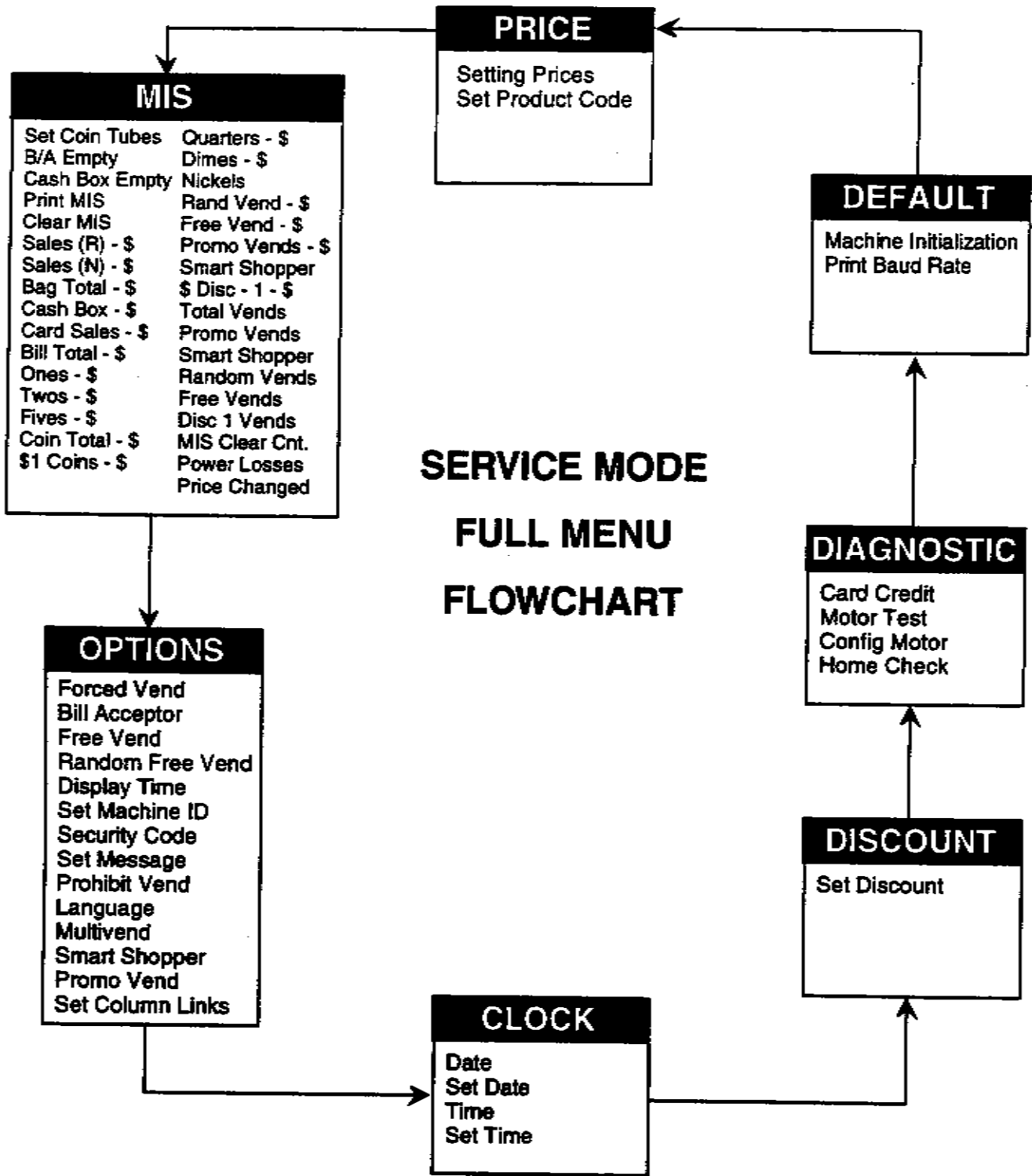

Figure 3-3. Service Mode Full Menu Flowchart

PRICE MENU

The **PRICE** menu contains the menu items used to set prices, shelf sizes, vending modes and product codes.

Price Sched

The purpose of **PRICE SCHED** is to select an active Price Schedule. (See **SET PRICE** section).

There are three Price Schedules that may be activated either manually or automatically by time and day. (See **AUTO PRICE MENU** section).

To select a price schedule:

- 1) Press the <SET> key until "PRICE SCHED-N ACTIVE" is displayed on the message center. (Where N = 1, 2, or 3.)
- 2) Use the <UP> or <DOWN> key to select schedule "1", "2", "3", or "AUTO N". The schedule that is selected will determine what prices the machine will use in vend operation.
- 3) If "AUTO" is selected, the active schedule number (N) is determined by the active **AUTO PRICE** times (See **AUTO PRICE MENU** section). (Times are displayed also). If no times have been set up or the **AUTO PRICE** schedules are disabled, Schedule 1 is used.

Set Price

The purpose of the **SET PRICE** option is to set each shelf to a specific price.

To set prices:

- 1) Press the <SET> key until "SET PRICE N-\$.XX" is displayed on the message center. (N = 1, 2, or 3, XX = .05 to 99.95).
- 2) Use the <UP> or <DOWN> key to select the desired price, then toggle the corresponding vend door to set the price. (Notice the column display will reflect the desired price for that shelf).

Shelf Size

The purpose of the **SHELF SIZE** option is to set a compartment to either "HALF" size or "FULL" size.

If the shelf sizes are set to "HALF", then there are 14 compartments to a shelf. If they are set to "FULL", then there are 7 compartments to a shelf. The default for all shelves is "HALF" size.

To set the size of a shelf:

- 1) Press the <SET> key until the message center displays "SHELF SIZE - HALF".
- 2) Use the <UP> or <DOWN> key to change the setting to either "HALF" or "FULL".
- 3) Toggle the door corresponding to the desired shelf and notice the column display will reflect the size configuration of the shelf. (i.e., "HALF" or "FULL").

Set Vend Mode

The purpose of the **SET VEND MODE** option is to set a shelf's vend mode to either "SHOP" or "FIFO" mode.

If a shelf is set to "FIFO" mode, the machine dispenses items in the order they were loaded. In other words, the First In is the First Out ("FIFO"). If this mode is to be implemented, it should be done after initialization, or after the shelves have been filled using the **SERVICE/FILLING SWITCH**, and before any vends have been made.

If the shelf is set to "SHOP" mode, the machine allows the customer to choose any product on a shelf provided that the compartment has not been sold. "SHOP" mode may be implemented at any time and is the default setting.

If "FIFO" mode is chosen, the machine will allow vends starting from the first compartment or zero position, incrementing up to compartment 14 if "HALF" size shelf, or compartment 7 if "FULL" size shelves.

NOTE:

If TURRET DELAY is active no shelves are allowed to be in "FIFO" mode. (See section TURRET DELAY).

To set "FIFO" or "SHOP" mode:

- 1) Press the <SET> key until the message center displays "SET VEND MODE - SHOP".
- 2) Use the <UP> or <DOWN> key to change the setting to either "FIFO" or "SHOP".
- 3) Toggle the door at the desired shelf and notice the column display will reflect the status of that shelf. (i.e., "FIFO" or "SHOP").

Multi Codes

The purpose of **MULTI CODES** is to set individual product codes for each shelf.

To set multicodes mode:

- 1) Press the <SET> key until the message center displays "MULTI CODES - OFF".
- 2) Use the <UP> or <DOWN> key to change the setting to either "ON" or "OFF".
- 3) Toggle the door at the desired shelf and notice the column display will reflect the status of that shelf. (i.e., "ON" or "OFF").

Set Product Code

The purpose of the **SET PROD CODE** is to set each shelf to a specific product code. (See **MULTI CODES** section).

To set product codes:

- 1) Press the <SET> key until the message center displays "SET PROD CODE - 0".
- 2) Use the <UP> or <DOWN> key to select the desired product code.
- 3) Toggle the door at the desired shelf and notice the column display will display the product code.
- 4) To set a different product code simply change the product code with the <UP> or <DOWN> keys and toggle any door to set the shelf to the new product code. The product codes range from 0 to 99.

NOTE:

Pressing the [NEXT] key at any time will advance to the following menu. All changes that have been set will automatically be saved.

MIS MENU

The MIS menu contains the menu items that are used to display and print the MIS data collected by the 548. This menu also contains items used to adjust the number of coins in the coin mech.

Set Coin Tubes

The purpose of the **SET COIN TUBES** option is empty the coin tubes or adjust the number of coins in the coin tubes.

Empty Tubes

- 1) *To empty the coin tubes:*
 - a) Press the <SET> key until "SET COIN TUBES - NONE" appears on the message center.
 - b) To empty the coin tubes completely, use the <UP> or <DOWN> keys until "SET COIN TUBES-EMPTY" is displayed on the message center.
 - c) Press the <SET> key.
 - d) To stop emptying coins, press any key.

NOTE:

The controller will dispense the number of coins recorded in the MIS coin count regardless of the physical coin count.

- 2) *To fill the coin tubes from the side of the coin mechanism:*
 - a) Use the <UP> or <DOWN> keys until "SET COIN TUBES - LOAD" is displayed on the message center.
 - b) Press the <SET> key.
- 3) Loading the coin tubes can also be performed by loading the coins through the top flight deck of the Coin Mech. at anytime during service mode.

\$1 Coins Added

- 1) "\$1 COINS ADDED - 0" appears on the message center.

- 2) Use the <UP> or <DOWN> keys to display the number of dollar coins that are being added through the side of the coin tube.
- 3) Press the <SET> key.

Quarters Added

- 1) "QUARTERS ADDED - 0" appears on the message center.
- 2) Use the <UP> or <DOWN> keys to display the number of quarters that are being added through the side of the coin tube.
- 3) Press the <SET> key.

Dimes Added

- 1) "DIMES ADDED - 0" appears on the message center.
- 2) Use the <UP> or <DOWN> keys to display the number of dimes that are being added through the side of the coin tube.
- 3) Press the <SET> key.

Nickels Added

- 1) "NICKELS ADDED - 0" appears on the message center.
- 2) Use the <UP> or <DOWN> keys to display the number of nickels that are being added through the side of the coin tube.
- 3) Press the <SET> key.

NOTE:

If the "EMPTY" option is used, the coin amounts that the coin mechanism delivers are recorded in the BAG TOTAL. (See BAG TOTAL section). If the "LOAD" option is used, the new coin totals will be reflected in the tube totals. (See COIN TOTAL, \$1 COINS, QUARTERS, DIMES, and NICKELS sections).

Bill Accept Empty

The purpose of **BILL ACCEPT EMPTY** is to clear the bill tallies after the bill stacker is emptied. The bill tallies are added to the **BAG TOTAL**.

To use the BILL ACCEPT EMPTY feature:

- 1) After the bill stacker is emptied, Press the <SET> key until "BILL ACCEPT EMPTY - NO" appears on the message center.
- 2) Use the <UP> or <DOWN> keys, display "YES" on the message center.
- 3) Press the <SET> key. (See **BAG TOTAL** section).

Cash Box Empty

The purpose of **CASH BOX EMPTY** is to clear the cash box tallies after it is emptied. The cash box tallies are added to the **BAG TOTAL**.

To use the CASH BOX EMPTY feature:

- 1) After the cash box is emptied, Press the <SET> key until "CASH BOX EMPTIED - NO" appears on the message center.
- 2) Use the <UP> or <DOWN> keys to display "YES" on the message center.
- 3) Press the <SET> key. (See **BAG TOTAL** section).

Print MIS

The **PRINT MIS** menu item sends the MIS data to the RS-232 port to be printed. The MIS menu data, software version, time and date, machine ID and audit number will be included.

NOTE:

To print MIS data use the Seiko DPU-411-21BU hand held printer and the CPC Vending printer harness. P/N 593-1800. available from CPC parts suppliers.

To send the MIS information:

- 1) Press the <SET> key until "PRINT MIS DATA - NO" appears on the message center.
- 2) Use the <UP> or <DOWN> keys to display "YES" on the message center.
- 3) Press the <SET> key.

Clear MIS Data

The purpose of the **CLEAR MIS DATA** function is to perform a MIS Reset, which will zero all totals except for the non-resettable information.

To clear the MIS information:

- 1) Press the <SET> key until "CLEAR MIS DATA - NO" appears on the message center.
- 2) Use the <UP> or <DOWN> keys, display "YES" on the message center.
- 3) Press the <SET> key. (See **MIS CLEAR COUNT** section).

Sales (R)

The purpose of **SALES (R)** is to display the total amount of sales that the machine has made since the last initialization or MIS Reset. "SALES (R)-\$.XX" will appear on the message center, where XX is the dollar amount. When the amount exceeds \$99999.95 it will restart at \$.00.

To display the resettable sales:

Press the <SET> key until "SALES (R)-\$.XX" appears on the message center. (Where XX is the dollar amount).

Sales (N)

The purpose of **SALES (N)** is to display the total amount of sales that the machine has made. It can never be reset. "SALES (N)-\$.XX" will appear on the message center, where XX is the dollar amount. When the amount exceeds \$99999.95 it will restart at \$.00.

To display the non-resettable sales:

Press the <SET> key until "SALES (N)-\$.XX" appears on the message center. (Where XX is the dollar amount).

Bag Total

The purpose of **BAG TOTAL** is to display the total amount of money that has been emptied from the bill acceptor and the coin box. When the amount exceeds \$99999.95 it will restart at \$.00.

To display the bag total:

Press the <SET> key until "BAG TOTAL-\$.XX" appears on the message center. (Where XX is the dollar amount).

Cash Box

The purpose of **CASH BOX** is to display the total amount of money in the cash box. When the amount exceeds \$99999.95 it will restart at \$.00.

To display the cash box total:

Press the <SET> key until "CASH BOX-\$XX" appears on the message center. (Where XX is the dollar amount).

Card Sales

The purpose of **CARD SALES** is to display the total amount of vend card sales. When the amount exceeds \$99999.95 it will restart at \$.00.

To display the card sales:

Press the <SET> key until "CARD SALES-\$ XX" appears on the message center. (Where XX is the dollar amount).

Bill Total

The purpose of **BILL TOTAL** is to display the total value of the bills held in the bill stacker. When the amount of bills exceeds 999 it will restart at \$.00.

To display the bill total:

Press the <SET> key until "BILL TOTAL- XX" appears on the message center. (Where XX is the dollar amount).

Ones

The purpose of **ONES** is to display the total number and value of one dollar bills held in the bill stacker. When the bills count exceeds 999 it will restart at 1.

To display the one dollar bill total:

Press the <SET> key until "ONES-N \$.XX" appears on the message center. (Where N is the number of bills and XX is the dollar amount).

Twos

The purpose of **TWOS** is to display the total number and value of two dollar bills held in the bill stacker. When the bill count exceeds 999 it will restart at 1.

To display the two dollar bill total:

Press the <SET> key until "TWOS-N \$.XX" appears on the message center. (Where N is the number of bills and XX is the dollar amount).

Fives

The purpose of **FIVES** is to display the total number and value of five dollar bills held in the bill stacker. When the bill count exceeds 999 it will restart at 1.

To display the five dollar bill total:

Press the <SET> key until "FIVES-N \$.XX" appears on the message center. (Where N is the number of bills and XX is the dollar amount).

Coin Total

The purpose of **COIN TOTAL** is to display the total value of the coins held in the coin tubes. When the value of the coins exceeds \$999.00 it will restart at \$.00.

To display the coin total:

Press the <SET> key until "COINS TOTAL-\$.XX" appears on the message center. (Where XX is the dollar amount).

\$1 Coins

The purpose of **\$1 COINS** is to display the total number and value of \$1 coins held in the coin mech tubes.

To display the \$1 coin total:

Press the <SET> key until "\$1 COINS-N \$.XX" appears on the message center. (Where N is the number of coins and XX is the dollar amount).

Quarters

The purpose of **QUARTERS** is to display the total number and value of quarters held in the coin mech tubes.

To display the quarter coin total:

Press the <SET> key until "QUARTERS-N \$.XX" appears on the message center. (Where N is the number of coins and XX is the dollar amount).

Dimes

The purpose of **DIMES** is to display the total number and value of dimes held in the coin mech tubes.

To display the dime coin total:

Press the <SET> key until "DIMES-N \$.XX" appears on the message center. (Where N is the number of coins and XX is the dollar amount).

Nickels

The purpose of **NICKELS** is to display the total number and value of nickels held in the coin mech tubes.

To display the nickels coin total:

Press the <SET> key until "NICKELS-N \$.XX" appears on the message center. (Where N is the number of coins and XX is the dollar amount).

Rand Vends-\$

The purpose of **RAND VENDS-\$** is to display the total monetary amount of random free vend sales that have occurred. When the number of random free vends exceeds 9999, random free vend value will restart at \$.00.

To display the random vend monetary total:

Press the <SET> key until "RAND VEND-\$.XX" appears on the message center. (Where XX is the dollar amount).

Free Vends-\$

The purpose of **FREE VENDS** is to display the total monetary amount of free vend sales that have occurred. When the number of free vends exceeds 9999, free vend value will restart at \$.00.

To display the free vend monetary total:

Press the <SET> key until "FREE VEND-\$.XX" appears on the message center. (Where XX is the dollar amount).

Disc 1- \$

The purpose of **DISC 1- \$** is to display the amount of money discounted from the scheduled prices while Discount 1 was active. When the number of Discount 1 exceeds 9999, the Discount 1 vend value will restart at \$.00.

To display the Discount 1 monetary total:

Press the <SET> key until "DISC 1 - \$.XX" appears on the message center. (Where XX is the dollar amount).

Disc 2 - \$

The purpose of **DISC 2 - \$** is to display the amount of money discounted from the scheduled prices while Discount 2 was active. When the number of Discount 2 exceeds 9999, the Discount 2 vend value will restart at \$.00.

To display the Discount 2 monetary total:

Press the <SET> key until "DISC 2 - \$.XX" appears on the message center. (Where XX is the dollar amount).

Disc 3 - \$

The purpose of **DISC 3 - \$** is to display the amount of money discounted from the scheduled prices while Discount 3 was active. When the number of Discount 3 exceeds 9999, the Discount 3 vend value will restart at \$.00.

To display the Discount 3 monetary total:

Press the <SET> key until "DISC 3 - \$.XX" appears on the message center. (Where XX is the dollar amount).

Total Vends

The purpose of **TOTAL VENDS** is to display the total number of vends that have occurred. When the amount of total vends exceeds 9999 it will restart at 1.

To display the total number of vends:

Press the <SET> key until "TOTAL VENDS - N" appears on the message center. (Where N is the number of vends.)

Sched 1 Vends

The purpose of **SCHED 1 VENDS** is to display the total number of vends that have occurred while Schedule 1 prices were active. Schedule 1 is the default schedule. When the amount of Schedule 1 vends exceeds 9999 it will restart at 1.

To display the number of vends during Price Schedule 1:

Press the <SET> key until "SCHED 1 VENDS - N" appears on the message center. (Where N is the number of vends).

Sched 2 Vends

The purpose of **SCHED 2 VENDS** is to display the total number of vends that have occurred while Schedule 2 prices were active. When the amount of Schedule 2 vends exceeds 9999 it will restart at 1.

To display the number of vends during Price Schedule 2:

Press the <SET> key until "SCHED 2 VENDS - N" appears on the message center. (Where N is the number of vends).

Sched 3 Vends

The purpose of **SCHED 3 VENDS** is to display the total number of vends that have occurred while Schedule 3 prices were active. When the amount of Schedule 3 vends exceeds 9999 it will restart at 1.

To display the number of vends during Price Schedule 3:

Press the <SET> key until "SCHED 3 VENDS - N" appears on the message center. (Where N is the number of vends).

Vends per Shelf

The purpose of **VENDS PER SHELF** is to display on the column display the total number of vends that have occurred on each of the shelves. When the number of vends per shelf exceeds 9999 it will restart at 1.

To display the vends per shelf:

Press the <SET> key until "VENDS PER SHELF" appears on the message center. The number of vends per shelf will appear in the price displays.

Random Vends

The purpose of **RANDOM VENDS** is to display the total number of random free vends that have occurred (See RNDM FREE VEND Section). When the amount of random vends exceeds 9999 it will restart at 1.

To display the total number of random free vends:

Press the <SET> key until "RANDOM VENDS - N" appears on the message center. (Where N is the number of vends).

Free Vends

The purpose of **FREE VENDS** is to display the total number of free vends that have occurred. When the amount of free vends exceeds 9999 it will restart at 1.

To display the total number of free vends:

Press the <SET> key until "FREE VENDS - N" appears on the message center. (Where N is the number of vends).

Disc 1 Vends

The purpose of **DISC 1 VENDS** is to display the total number of discounted vends while Discount 1 was active. When the amount of Discount 1 vends exceeds 9999 it will restart at 1.

To display the total number of vends while discount 1 was active:

Press the <SET> key until "DISC 1 VENDS - N" appears on the message center. (Where N is the number of vends).

Disc 2 Vends

The purpose of **DISC 2 VENDS** is to display the total number of discounted vends while Discount 2 was active. When the amount of Discount 2 vends exceeds 9999 it will restart at 1.

To display the total number of vends while discount 2 was active:

Press the <SET> key until "DISC 2 VENDS - N" appears on the message center. (Where N is the number of vends).

Disc 3 Vends

The purpose of **DISC 3 VENDS** is to display the total number of discounted vends while Discount 3 was active. When the amount of Discount 3 vends exceeds 9999 it will restart at 1.

To display the total number of vends while discount 3 was active:

Press the <SET> key until "DISC 3 VENDS - N" appears on the message center. (Where N is the number of vends).

MIS Clear Count

The purpose of **MIS CLEAR COUNT** is to display the number of times that the MIS has been cleared via the MIS CLEAR menu item or "FULL" machine initialization. (See CLEAR MIS DATA and MACHINE INIT sections). This data is non-resettable.

To display the number of times the MIS has been cleared:

Press the <SET> key until "MIS CLEAR COUNT-N" appears on the message center. (Where N is the number of clears).

Power Losses

The purpose of **POWER LOSSES** is to display the last time and date that the machine lost power. If the machine has never lost power, "NOT APPLICABLE" will be displayed. This data is non-resettable.

To display the last time the machine lost power:

- 1) Press the <SET> key until "POWERLOSSES - NO" appears on the message center.
- 2) By using the <UP> or <DOWN> keys, displaying "YES" on the message center and Pressing the <SET> key, will display the last time, day and date the power to the machine had been off.

Price Changed

The purpose of **PRICE CHANGED** is to display the last time and date that a price was changed. If the prices have never been changed, then "NOT APPLICABLE" will be displayed. This data is non-resettable.

To display the last time a price changed:

- 1) Press the <SET> key until "PRICE CHANGED - NO" appears on the message center.
- 2) By using the <UP> or <DOWN> keys, displaying "YES" on the message center and Pressing the <SET> key, will display the last time, day and date a price had changed. (To set or change prices see SET PRICE section).

Out of Service

The purpose of **OUT OF SERVICE** is to display the last time and date that the machine went out of service. If the machine has never gone out of service then "NOT APPLICABLE" will be displayed. This data is non-resettable.

To display the last time the machine went out of service:

- 1) Press the <SET> key until "OUT OF SERVICE - NO" appears on the message center.
- 2) By using the <UP> or <DOWN> keys, displaying "YES" on the message center and Pressing the <SET> key, will display the last time, day and date the machine went out of service.

Time Over Health

The purpose of **TIME OVER HEALTH** is to display the amount of time the refrigerated compartment has been over the health temperature. If the compartment has not exceeded the health temperature after the Pull Down period then "NOT APPLICABLE" will be displayed, otherwise the length of time the compartment has been over the health temperature and the maximum temperature that the compartment has reached will be displayed.

To display Time Over Health:

- 1) Press the <SET> key until "TIME OVER HEALTH - NO" appears on the message center.
- 2) Use the or <UP> or <DOWN> keys to display "YES"
- 3) Press the <SET> key.
- 4) "HH.MM.SS XX F MAX" will appear on the message center. If the temperature in the refrigerated compartment did not exceed the

maximum health temperature then "NOT APPLICABLE" will appear on the message center. (Where HH is hours, MM is minutes, SS is seconds, and XX is degrees Fahrenheit).

Max Temperature

The purpose of **MAX TEMPERATURE** is to allow the operator to display the maximum temperature that the refrigerated compartment has achieved after the machine has reached the pull down temperature.

The message center will display the maximum temperature along with the date and time the maximum temperature was achieved.

If the temperature inside the refrigerated compartment has not reached the pull down temperature then "MIN TEMP NOT REACHED" will appear on the message center.

To display the maximum temperature:

- 1) Press the <SET> key until "MAX TEMPERATURE-NO" appears on the message center.
- 2) Use the <UP> or <DOWN> keys to display "YES".
- 3) Press the <SET> key. "TTF MM/DD/YY HH.NNXM" will appear on the message center. (Where TT is the maximum temperature in Fahrenheit, MM is the month, DD is the day, YY is the year, HH is the hour, NN is the minute, and XM is either AM or PM). If the temperature inside the refrigerated compartment has not reached the pull down temperature then "MIN TEMP NOT REACHED" will appear on the message center.

Min Temperature

The purpose of **MIN TEMPERATURE** is to allow the operator to display the minimum temperature that the refrigerated compartment has achieved after the machine has reached the pull down temperature.

The message center will display the minimum temperature along with the date and time the minimum temperature was achieved.

If the temperature inside the refrigerated compartment has not reached the pull down temperature then "MIN TEMP NOT REACHED" will appear on the message center.

To display the minimum temperature:

- 1) Press the <SET> key until "MIN TEMPERATURE-NO" appears on the message center.
- 2) Use the <UP> or <DOWN> keys to display "YES"
- 3) Press the <SET> key. "TTF MM/DD/YY HH.NNXM" will appear on the message center. (Where TT is the minimum temperature in Fahrenheit, MM is the month, DD is the day, YY is the year, HH is the hour, NN is the minute, and XM is either for AM or PM.) If the temperature inside the refrigerated compartment has not reached the pull down temperature, "MIN TEMP NOT REACHED" will appear on the message center.

Clock Changes

The purpose of **CLOCK CHANGES** is to display the number of times the clock has been changed. If the clock has never been changed then "NOT APPLICABLE" will be displayed. This data is non-resettable.

To display the number of times the clock has been changed:

- 1) Press the <SET> key until "CLOCK CHANGES - NO" appears on the message center.
- 2) By using the <UP> or <DOWN> keys, displaying "YES" on the message center and pressing the <SET> key, "TIMES CHANGED - N" will appear. (Where N is the number of times the clock has changed. To change or set the date, time, or day see section SET DATE, SET TIME, or SET DAY).

NOTE:

Pressing the <NEXT> key at any time will advance to the following menu. All changes that have been set will automatically be saved.

OPTIONS MENU

The **OPTIONS** menu contains the menu items used to enable/disable the Multiview, Forced Vend, Sold Out Check, Free Vend, Random Free Vend, Display Time, Column Display and Prohibit Overbuy options. In this menu the Bill Acceptor can be enabled, the display language selected and the Security Code, Machine ID and Point of Sale message programmed.

Multiview

The purpose of **MULTIVIEW** is to rotate the turret three sections every three minutes. The turret will not rotate if there is credit pending in the machine or if a vend or turret rotation had occurred 15 seconds prior to the scheduled **MULTIVIEW** rotation.

If **MULTIVIEW** is selected, the active time period must be specified. A time period is described by start and end times between and including the start and end days.

For example: If **MULTIVIEW** should be in effect from 9:00AM to 5:00PM on Monday through Friday, set the **START TIME** to "9:00AM", the **STOP TIME** to 5:00PM, the **START DAY** to "MONDAY" and the **END DAY** to "FRIDAY".

To describe a complete 24 hour time period, set the **START TIME** to some time, 9:00AM for example. Then set the **END TIME** to 1 minute less than that time, 8:59AM in this case.

To describe a complete week time period, set the **START DAY** to some day, Monday for example. Then set the **END DAY** to the previous day, Sunday in this case.

*To use the **MULTIVIEW** option:*

- 1) Press the <SET> key until "MULTIVIEW - OFF" appears on the message center. Use the <UP> or <DOWN> keys to display "ON".
- 2) Press the <SET> key.

START TIME

"START TIME - HH:MM XM" will appear on the message center. This is the time of day that **MULTIVIEW** will become active. To continue, Press the <SET> key.

Set Start Time

"SET START TIME - NO" appears on the message center.

To set the start time:

- 1) Use the <UP> or <DOWN> keys to display "YES" on the message center.
- 2) Press the <SET> key.

Set Hours

"SET HOURS - HH XM" will appear on the message center.

To change the hour:

- 1) Use the **UP** or **DOWN** keys to display the correct hour.
- 2) Press the **<SET>** key.

Set Mins

"SET MINS - MM" will appear on the message center.

To change the minutes:

- 1) Use the **UP** or **DOWN** keys to display the correct minutes.
- 2) Press the **<SET>** key.

STOP TIME

"STOP TIME - HH.MM XM" will appear on the message center. This shows the time of day that **MULTIVIEW** will become inactive. To continue, Press the **<SET>** key.

Set Stop Time

"SET STOP TIME - NO" appears on the message center.

To set the stop time:

- 1) Use the **UP** or **DOWN** keys to display "YES" on the message center
- 2) Press the **<SET>** key.

Set Hours

"SET HOURS - HH XM" will appear on the message center.

To change the hour:

- 1) Use the **UP** or **DOWN** keys to display the correct hour.
- 2) Press the **<SET>** key.

Set Mins

"SET MINS - MM" will appear on the message center.

To change the minutes:

- 1) Use the **<UP>** or **<DOWN>** keys to display the correct minutes
- 2) Press the **<SET>** key.

START DAY

"START DAY-WWWDAY" will appear on the message center. This shows the day of the week that **MULTIVIEW** will become active. To continue, Press the **<SET>** key.

Set Start Day

"SET START DAY-NO" appears on the message center.

To set the start day:

- 1) Use the **<UP>** or **<DOWN>** keys to display "YES" on the message center.
- 2) Press the **<SET>** key.

Set Day

"SET DAY - WWWDAY" will appear on the message center.

To change the day:

- 1) Use the **<UP>** or **<DOWN>** keys to display the day.
- 2) Press the **<SET>** key.

END DAY

"END DAY-WWWDAY" will appear on the message center. This shows the day of the week that **MULTIVIEW** will become inactive. To continue, Press the **<SET>** key.

Set End Day

"SET END DAY-NO" appears on the message center.

To set the end day:

- 1) Use the **<UP>** or **<DOWN>** keys to display "YES" on the message center.
- 2) Press the **<SET>** key.

Set Day

"SET DAY - WWWDAY" will appear on the message center.

To change the day:

- 1) Use the <UP> or <DOWN> keys to display the day.
- 2) Press the <SET> key.

NOTE:

HH is hours, MM is minutes, XM is AM or PM, and WWW is the day of the week, i.e. SUN, MON, TUES, etc.)

Forced Vend

The purpose of **FORCED VEND** is to prevent the 548 from being used as a change machine. If credit is established in vend mode and the coin return is Pressed, "MUST MAKE SELECTION" is displayed if the **FORCED VEND** option is active. **FORCED VEND - OFF** is the default.

To set the FORCED VEND option:

- 1) Press the <SET> key until "FORCED VEND - OFF" appears on the message center.
- 2) Use the <UP> or <DOWN> keys to display "ON".
- 3) Press the <SET> key.

Bill Acceptor

The purpose of **BILL ACCEPTOR** is to enable the bill acceptor and the type of bills that the bill acceptor will accept.

To enable the bill acceptor:

- 1) Press the <SET> key until "BILL ACCEPTOR - OFF" appears on the message center.
- 2) Use the <UP> or <DOWN> keys to display "ON".
- 3) Press the <SET> key.

\$1 Bills

"\$1 BILLS - REJECT" will appear on the message center.

To accept one dollar bills:

- 1) Use the <UP> or <DOWN> keys to display "ACCEPT".
- 2) Press the <SET> key.

\$2 Bills

"\$2 BILLS - REJECT" will appear on the message center.

To accept two dollar bills:

- 1) Use the <UP> or <DOWN> keys to display "ACCEPT".
- 2) Press the <SET> key.

\$5 Bills

"\$5 BILLS - REJECT" will appear on the message center.

To accept five dollar bills:

- 1) Use the <UP> or <DOWN> keys to display "ACCEPT".
- 2) Press the <SET> key.

Sold Out Check

The purpose of **SOLD OUT CHECK** is to assist in the detection of possible product tampering. When this option is active, "SOLD" will be indicated on the column display for each compartment selected and "CHECK SOLD OUT DOORS" will appear on the message center at the start of the service menu.

For each compartment that displays a "SOLD" message on the column display, the door should be opened. Any product found in a sold compartment should be discarded. The column display will change to "NONE". When all the "SOLD" compartments have been toggled to "NONE", the column display will display the current prices and the message center will display "**** SERVICE MENU ****".

After filling the machine and closing the main door, "SET FIRST EMPTY" will be displayed. The turret should be turned to the first empty compartment on each shelf (starting from Section 1) and the door toggled. The compartments from that Section to Section 7 will be set to "NOT FILLED". Any shelf not set will be considered completely full once the <SET> key has been pressed.

To use the **SOLD OUT CHECK** option:

- 1) Press the <SET> key until "SOLD OUT CHECK OFF" appears on the message center.
- 2) Use the <UP> or <DOWN> keys to display "ON".
- 3) Press the <SET> Free Vend

The purpose of **FREE VEND** is to put the machine in free vend mode. When this option is active, the column display will show .00, and "MAKE FREE SELECTION" will be displayed in Vend Mode unless a point of sale message is invoked. (See **SET MESSAGE** section).

To use the **FREE VEND** option:

- 1) Press the <SET> key until "FREE VEND - OFF" appears on the message center.
- 2) Use the <UP> or <DOWN> keys to display "ON".
- 3) Press the <SET> key.

Random Free Vend

The purpose of **RNDM FREE VEND** is to randomly give a free vend. The occurrence of a free vend can be set from 1 in 50 to 1 in 3000. When a random free vend occurs, the vend price will be returned and the message center will display "YOU ARE A WINNER".

To use the **RNDM FREE VEND** option:

- 1) Press the <SET> key until "RNDM FREE VEND - OFF" appears on the message center.
- 2) Use the <UP> or <DOWN> arrow keys to display "ON".
- 3) Press the <SET> key.

Odds

"ODDS - 1 IN N" will appear on the message center.

To increment or decrement the odds:

- 1) Use the <UP> or <DOWN> keys.
- 2) Press the <SET> key. (N = 50 to 3000.)

Display Time

The purpose of **DISPLAY TIME** is to display on the message center during vend mode the time, day and date in vend mode providing that no point of sale message is active, the machine is not **OUT OF SERVICE**, and the machine is not in **EXACT CHANGE MODE**.

To use the **DISPLAY TIME** option:

- 1) Press the <SET> key until "DISPLAY TIME - OFF" appears on the message center.
- 2) Use the <UP> or <DOWN> keys to display "ON".
- 3) Press the <SET> key.

Set Machine ID

The purpose of **SET MACHINE ID** is to set a machine ID of up to 12 letters, numbers, or characters.

To set the **MACHINE ID**:

- 1) Press the <SET> key until "SET MACHINE ID - NO" appears on the message center.
- 2) Use the <UP> or <DOWN> keys to display "YES".
- 3) Press the <SET> key.
- 4) "MACH ID- _____" will appear on the screen.
- 5) Use the <UP> or <DOWN> keys to change the character that is being displayed.
- 6) When the desired character is displayed press the <SET> key.
- 7) The flashing " ^ " character signifies the current character.
- 8) If less than 12 characters, use the end bracket "] " to signify the end of message routine.
- 9) When all the characters in the ID are set or an end bracket character is used, the message center will again display "SET MACHINE ID - NO".
- 10) Press the <SET> key for the next menu item.

NOTE:

The machine ID can be displayed temporarily by Pressing the black <BLANK> key and then the <I> key on the key pad at any time.

Security Code

The purpose of the **SECURITY CODE** option, is to prevent access to certain features of the 548.

If the security code option is active, the only menus that would be accessible without the correct security code are: **PRICE, MIS, AUTOPRICE, and DIAGNOSTICS.**

When the security code option is active, "SECURITY CODE - _ _ _ _" will be displayed in the Service Mode after clearing all error messages (if applicable) and "CHECK SOLD OUT DOORS" (if applicable) appears.

The operator must then enter the security code. If the code is correct, "FULL ACCESS GRANTED" will be temporarily displayed and all the service menus are available. If the code is incorrect, only the menus listed above will be available.

To set the SECURITY CODE:

- 1) Press the <SET> key until "SECURITY CODE - OFF" appears on the message center.
- 2) Use the <UP> or <DOWN> keys to display "ON"
- 3) Press the <SET> key. "EDIT SEC CODE - NO" appears on the message center.
- 4) Use the <UP> or <DOWN> arrow keys to display "YES" and Press the <SET> key.
- 5) "SECURITY CODE _ _ _ _" will appear on the screen.
- 6) Use the <UP> or <DOWN> keys to change the character that is being displayed.
- 7) When the desired character is displayed Press the <SET> key.
- 8) The flashing "^" character signifies the current character. If less than 4 characters use the end bracket "]" to signify the end of message routine.
- 9) When all the characters in the security code are set or an end bracket character is used, the message center will again display "EDIT SEC CODE - NO".
- 10) Depress the <SET> key for the next menu item.

Set Message

The **SET MESSAGE** option is used to set a user definable Point of Sale Message.

The Point of Sale Message may be a fixed length message, which can be up to 20 characters long or a scrolling message, which can be up to 300 characters long. Either type of message will be displayed on the message center provided that the machine is in Vend Mode, not **OUT OF SERVICE**, and not in **EXACT CHANGE MODE.**

To set the Point of Sale Message:

- 1) Press the <SET> key until "SET MESSAGE - NO" appears on the message center.
- 2) Use the <UP> or <DOWN> keys to display "FIXED" or "SCROLL"
- 3) Press the <SET> key.
- 4) "EDIT MESSAGE - NO" will appear on the Message Center.
- 5) Use the <UP> or <DOWN> keys to display "YES".
- 6) Press the <SET> key. " _ _ _ _ _ _ _ _ _ _" will appear on the screen.
- 7) Use the <UP> or <DOWN> keys to change the character that is being displayed.
- 8) When the desired character is displayed Press the <SET> key.
- 9) The flashing "^" character signifies the current character. The end bracket "]" signifies the end of message character.
- 10) When all the characters in the ID are set or an end bracket character is used, the message center will again display "SET MESSAGE - NO".
- 11) Depress the <SET> key for the next menu item.

Column Display

The purpose of **COLUMN DISPLAY** is to eliminate the "Sold" messages on the column display when a compartment has been sold.

If "COLUMN DISPLAY-PRICE" is selected, the column will continue to display the price of each sold compartment. If "COLUMN DISPLAY-SOLD" is set, then "Sold" will be displayed on the column for each sold compartment. In either case, each compartment can only be sold one time. "ITEM PREVIOUSLY SOLD" will be displayed on the message center when attempting to open a sold compartment.

To set the column display after a vend:

- 1) Press the <SET> key until "COLUMN DISPLAY-SOLD" is displayed on the message center.
- 2) Use the <UP> or <DOWN> keys to display "PRICE".
- 3) Press the <SET> key for the price to be displayed after a vend, otherwise Press the <SET> key for the next menu item. (The default is "SOLD").

Prohibit Vending

The purpose of **PROHIBIT VENDING** is to allow the operator to put the machine **OUT OF SERVICE** without an error. When the service door is closed, the machine will be out of service, but there will be no error messages shown when service mode is entered.

To set the machine out of order:

- 1) Press the <SET> key until "PROHIBIT VENDING-NO" is displayed on the message center.
- 2) Use the <UP> or <DOWN> arrow keys to display "YES".
- 3) Press the <SET> key.

Language

The purpose of **LANGUAGE** is to allow the operator to display the vend message in either **ENGLISH**, **FRENCH**, or **SPANISH**. The default language is English.

To set the vend messages to a language:

- 1) Press the <SET> key until "LANGUAGE - ENGLISH" appears on the message center.
- 2) Use the <UP> or <DOWN> keys to display either "ENGLISH", "FRENCH", or "SPANISH"
- 3) Press the <SET> key.

Prohibit Overbuy

The purpose of **PROHIBIT OVERBUY** is to not allow an attempted buy when the correct change is unavailable in the coin tubes. Forced Vend option must be OFF to enable this feature.

To set the PROHIBIT OVERBUY option:

- 1) Press the <SET> key until "PROHIBIT OVERBUY-NO" is displayed on the message center.
- 2) Use the <UP> or <DOWN> keys to display "YES"
- 3) Press the <SET> key.

NOTE:

Pressing the [NEXT] key at any time will advance to the following menu. All changes that have been set will automatically be saved.

CLOCK MENU

The **CLOCK** menu contains the menu items that set the internal clock. Depress the black <BLANK> key on the key pad and then the <D> key to temporarily display the time, date and day of week.

DATE

"DATE - MM/DD/YY" will appear on the message center. This shows the current date. To continue, press the <SET> key.

Set Date

"SET DATE - NO" appears on the message center.

To change the date:

- 1) Use the <UP> or <DOWN> keys to display "YES" on the message center.
- 2) Press the <SET> key.

Set Day of Month

"SET DAY OF MONTH - DD" will appear on the message center. To change the day of the month:

- 1) Use the <UP> or <DOWN> keys to display the day of the month.
- 2) Press the <SET> key.

Set Month

"SET MONTH - MM" will appear on the message center.

To change the month:

- 1) Use the <UP> or <DOWN> keys to display the correct month
- 2) Press the <SET> key.

Set Year

"SET YEAR - YY" will appear on the message center.

To change the year:

- 1) Use the <UP> or <DOWN> keys to display the correct year.
- 2) Press the <SET> key.

TIME

"TIME - HH.MM XM WWW"* will appear on the message center. This is the current time. To continue, press the <SET> key.

Set Time

"SET TIME - NO" appears on the message center.

To change the time:

- 1) Use the <UP> or <DOWN> keys to display "YES" on the message center.
- 2) Press the <SET> key.

Set Hours

"SET HOURS - HH XM" will appear on the message center.

To change the hour:

- 1) Use the <UP> or <DOWN> keys to display the correct hour.
- 2) Press the <SET> key.

Set Mins

"SET MINS - MM" will appear on the message center.

To change the minutes:

- 1) Use the <UP> or <DOWN> keys to display the correct minutes.
- 2) Press the <SET> key.

Set Day

"SET DAY - WWWDAY" will appear on the message center.

To change the day:

- 1) Use the <UP> or <DOWN> keys to display the day.
- 2) Press the <SET> key.

(* HH is hours, MM is minutes, XM is AM or PM, and WWW is the day of the week, i.e. SUN, MON, TUES, etc.)

TURRET MENU

The **TURRET** menu contains the menu items used to reserve turret sections in the machine for vending at a later time.

TURRET DELAY

The purpose of **TURRET DELAY** is to prohibit vending in certain sections of the turret. Sections 2-7 may be reserved until some later time.

If **TURRET DELAY** is active and the turret is rotated into a reserved section, the machine will continue to rotate into the first vendible section, the message center will display "RESERVED SECTION" and the column display will show "— —" in place of the prices.

When the delay end time has been reached, the delay is disabled until the machine is refilled. Turret delay is active for only 24 hours. It must be reset every 24 hours.

NOTE:

To make **TURRET DELAY** active, no shelves can be in "FIFO" mode. (See section SET VEND MODE)

To use the **TURRET DELAY** option:

- 1) Press the <SET> key until "TURRET DELAY - OFF" appears on the message center.
- 2) Use the <UP> or <DOWN> keys to display "ON"
- 3) Press the <SET> key.

Delay Sections

"DELAY SECTIONS N - 7" will appear on the message center, where N is the starting "jocked out" section, that is reserved for later vending.

- 1) Use the <UP> or <DOWN> keys to display the desired starting reserved turret section.
- 2) Press the <SET> key.

Stop Time

"STOP TIME - HH.MM XM" will appear on the message center. This is the time of day that the turret delay will end. To continue, press the <SET> key.

Set Stop Time

"SET STOP TIME - NO" appears on the message center.

To change stop time:

- 1) Use the <UP> or <DOWN> keys to display "YES" on the message center.
- 2) Press the <SET> key.

Set Hours

"SET HOURS - HH XM" will appear on the message center.

To change the hour:

- 1) Use the <UP> or <DOWN> keys to display the correct hour.
- 2) Press the <SET> key.

Set Mins

"SET MINS - MM" will appear on the message center.

To change the minutes:

- 1) Use the <UP> or <DOWN> keys to display the correct minutes
- 2) Press the <SET> key.

NOTE:

Pressing the [NEXT] key at any time will advance to the following menu. All changes that have been set will automatically be saved.

AUTO PRICE MENU

The **AUTO PRICE** menu contains the menu items that set the time periods during which the different price schedules will become active when **AUTO PRICE** is enabled.

A time period is described by start and end times between and including the start and end days. For example if price schedule 2 should be in effect from 9:00AM to 5:00PM on Monday through Friday, set the **START TIME** to 9:00AM, the **STOPTIME** to 5:00PM, the **START DAY** to **MONDAY** and the **END DAY** to **FRIDAY**.

To describe a complete 24 hour time period, set the **START TIME** to some time, 9:00AM for example. Then set the **END TIME** to 1 minute less than that time, 8:59AM in this case.

To describe a complete week time period, set the **START DAY** to some day, Monday for example. Then set the **END DAY** to the previous day, Sunday in this case. Setting the prices in the schedules is done in the **PRICE MENU**.

The following instructions can be used for both Schedule 2 and 3.

NOTE:

In order to activate an **AUTO PRICE** Schedule, the **PRICE SCHED-AUTO N** in the **PRICE MENU** must be selected after setting the time periods (See **PRICE SCHED-N ACTIVE** section).

ENABLE SCHED N

The purpose of **ENABLE SCHED N** is to set the time period that price schedule N will be active.

To enable schedule N:

- 1) Press the <SET> key until "ENABLE SCHED N - NO" appears on the message center.
- 2) Use the <UP> or <DOWN> keys to display "YES"
- 3) Press the <SET> key.

START TIME

"START TIME - HH.MM XM" will appear on the message center. This shows the time of day that the schedule N prices will become active. To continue, press the <SET> key.

Set Start Time

"SET START TIME - NO" appears on the message center.

To set the start time:

- 1) Use the <UP> or <DOWN> keys to display "YES" on the message center.
- 2) Press the <SET> key.

Set Hours

"SET HOURS - HH XM" will appear on the message center.

To change the hour:

- 1) Use the <UP> or <DOWN> keys to display the correct hour
- 2) Press the <SET> key.

Set Mins

"SET MINS - MM" will appear on the message center.

To change the minutes:

- 1) Use the <UP> or <DOWN> keys to display the correct minutes
- 2) Press the <SET> key.

STOP TIME

"STOP TIME - HH.MM XM" will appear on the message center. This shows the time of day that the schedule N prices will become inactive. To continue, Press the <SET> key.

Set Stop Time

"SET STOP TIME - NO" appears on the message center.

To set the stop time:

- 1) Use the <UP> or <DOWN> keys to display "YES" on the message center.
- 2) Press the <SET> key.

Set Hours

"SET HOURS - HH XM" will appear on the message center.

To change the hour:

- 1) Use the <UP> or <DOWN> keys to display the correct hour
- 2) Press the <SET> key.

Set Mins

"SET MINS - MM" will appear on the message center.

To change the minutes:

- 1) Use the <UP> or <DOWN> keys to display the correct minutes.
- 2) Press the <SET> key.

START DAY

"START DAY-WWWDAY" will appear on the message center. This shows the day of the week that the schedule N prices will become active. To continue, press the <SET> key.

Set Start Day

"SET START DAY-NO" appears on the message center.

To set the start day:

- 1) Use the <UP> or <DOWN> keys to display "YES" on the message center.
- 2) Press the <SET> key.

Set Day

"SET DAY - WWWDAY" will appear on the message center.

To change the day:

- 1) Use the <UP> or <DOWN> keys to display the day.
- 2) Press the <SET> key.

END DAY

"END DAY-WWWDAY" will appear on the message center. This shows the day of the week that the schedule N prices will become inactive. To continue, press the <SET> key.

Set End Day

"SET END DAY-NO" appears on the message center.

To set the end day:

- 1) Use the <UP> or <DOWN> keys to display "YES" on the message center.
- 2) Press the <SET> key.

Set Day

"SET DAY - WWWDAY" will appear on the message center.

To change the day:

- 1) Use the <UP> or <DOWN> keys to display the day.
- 2) Press the <SET> key.

DISCOUNT MENU

The **DISCOUNT** menu contains the menu items that set the time periods during which the discounts will become active.

A time period is described by start and end times between and including the start and end days.

For example: If a discount is desired from 9:00AM to 5:00PM on Monday through Friday, set the **START TIME** to 9:00AM, the **STOP TIME** to 5:00PM, the **START DAY** to **MONDAY** and the **END DAY** to **FRIDAY**.

To describe a complete 24 hour time period, set the **START TIME** to some time, 9:00AM for example. Then set the **END TIME** to 1 minute less than that time, 8:59AM in this case.

To describe a complete week time period, set the **START DAY** to some day, Monday for example. Then set the **END DAY** to the previous day, Sunday in this case.

The following instructions apply to all three discounts.

SET DISCOUNT N

The purpose of **SET DISCOUNT N** is to set the time period that **DISCOUNT N** will be active.

To enable DISCOUNT N:

- 1) Press the <SET> key until "SET DISCOUNT N- NO" appears on the message center.
- 2) Use the <UP> or <DOWN> keys to display "YES".
- 3) Press the <SET> key.

Discount

This menu item sets the amount that will be deducted from all prices in the active schedule when the discount is active.

If the discount is greater than or equal to the price of an item, the price will become \$.00.

To set the DISCOUNT:

- 1) Press the <SET> key until "DISCOUNT - \$

.XX" is displayed on the message center. (XX = .05 to 99.95.)

- 2) Use the <UP> or <DOWN> key to select the desired discount.
- 3) Press the <SET> key.

START TIME

"START TIME - HH.MM XM" will appear on the message center. This shows the time of day that Discount N will become active. To continue, press the <SET> key.

Set Start Time

"SET STARTTIME - NO" appears on the message center.

To set the start time:

- 1) Use the <UP> or <DOWN> keys to display "YES" on the message center
- 2) Press the <SET> key.

Set Hours

"SET HOURS - HH XM" will appear on the message center.

To change the hours:

- 1) Use the <UP> or <DOWN> keys to display the correct hour.
- 2) Press the <SET> key.

Set Mins

"SET MINS - MM" will appear on the message center.

To change the minutes:

- 1) Use the <UP> or <DOWN> keys to display the correct minutes.
- 2) Press the <SET> key.

STOP TIME

"STOP TIME - HH.MM XM" will appear on the message center. This shows the time of day that Discount N will become inactive. To continue, press the <SET> key. "SET STOP TIME - NO" appears on the message center.

To set the stop time:

- 1) Use the <UP> or <DOWN> keys to display "YES" on the message center.
- 2) Press the <SET> key.

Set Hours

"SET HOURS - HH XM" will appear on the message center.

To change the hours:

- 1) Use the <UP> or <DOWN> keys to display the correct hour.
- 2) Press the <SET> key.

Set Mins

"SET MINS - MM" will appear on the message center.

To change the minutes:

- 1) Use the <UP> or <DOWN> keys to display the correct minutes
- 2) Press the <SET> key.

START DAY

"START DAY-WWWDAY" will appear on the message center. This shows the day of the week that Discount N will become active. To continue, press the <SET> key.

Set Start Day

"SET START DAY-NO" appears on the message center.

To set the start day:

- 1) Use the <UP> or <DOWN> keys to display "YES" on the message center.
- 2) Press the <SET> key.

Set Day

"SET DAY - WWWDAY" will appear on the message center.

To change the day:

- 1) Use the <UP> or <DOWN> keys to display the day
- 2) Press the <SET> key.

End Day

"END DAY-WWWDAY" will appear on the message center. This shows the day of the week that Discount N will become inactive. To continue, press the <SET> key.

Set End Day

"SET END DAY-NO" appears on the message center.

To set the end day:

- 1) Use the <UP> or <DOWN> keys to display "YES" on the message center.
- 2) Press the <SET> key.

Set Day

"SET DAY - WWWDAY" will appear on the message center.

To change the day:

- 1) Use the <UP> or <DOWN> keys to display the day.
- 2) Press the <SET> key.

DIAGNOSTICS MENU

The **DIAGNOSTICS** menu contains the menu items that perform system diagnostics.

Health Test

The purpose of the **HEALTH TEST** is to test the health control system.

*To perform a **HEALTH TEST**:*

- 1) Open the service door and the large main door.
- 2) Locate the temperature probe on the inside bottom portion of the large main door near the fluorescent light.
- 3) Place a hand on the probe to raise the temperature above 45° F.
- 4) Check the temperature by depressing on the key pad the black <BLANK> key and then the <F> key.
- 5) The message center will temporarily display the "TEMPERATURE = XX F", where XX is the temperature being read by the probe.
- 6) When the temperature rises above 45° F, close the main door.
- 7) Use the <UP> or <DOWN> arrow keys to display "YES".
- 8) Press the <SET> key.
- 9) Close the Service door.
- 10) Press the black <BLANK> key and then the <H> key to display the health control status on the message center. The display should temporarily read "HEALTHCONTROL ON".
- 11) Wait approximately 20 seconds for the machine to go out of service.

Card Credit

The purpose of the **CARD CREDIT** menu item is to test the Debit Card System (if installed).

The **CARD CREDIT** menu item shows the amount of Debit Card credit currently established when a Debit Card is inserted into the Debit Card reader. The machine will accept as much credit as the debit card system is programmed to transfer.

Depress the escrow return button on the Debit Card System to return the credit to the card. The **CARD CREDIT** display should then return to "CARD CREDIT - \$.00".

Set Zero Pos

The purpose of the **SET ZERO POSITION** menu item is to locate the zero position on the turret.

To locate zero pos:

- 1) Use the <UP> or <DOWN> arrow keys to display "YES".
- 2) Press the <SET> key.
- 3) The message center will then display "TURN UNTIL ZERO POS" unless the turret is already located on the zero position switch.
- 4) If the turret is not on the zero position switch, turn the turret by depressing the <ROTATE LEFT TURRET> or <ROTATE RIGHT TURRET> key until the "TURN UNTIL ZERO POS" message disappears from the message center.

DEFAULT MENU

The **DEFAULT** menu contains menu items that perform machine initializations.

Machine Init

MACHINE INIT allows the machine to be initialized to a default setting.

There are two types of machine initializations; **FULL** and **OPTIONS**.

The **OPTIONS** initialization resets only the 548 options to default states. This type of initialization will turn off all the options that can be set in the **OPTIONS MENU**. (See **OPTIONS MENU** section).

*To perform an **OPTIONS** initialization:*

- 1) Use the <UP> or <DOWN> key to display "MACHINE INIT - OPTIONS" on the message center.
- 2) Press the <SET> key.

The **FULL** initialization resets the 548 to default states. This type of initialization will initialize the entire machine: **PRICES**, **MIS** totals (except for the non-resettables), **OPTIONS**, **TURRET DELAYS**, **AUTO PRICES**, and **DISCOUNTS**.

*To perform a **FULL** initialization:*

- 1) Use the <UP> or <DOWN> key to display "MACHINE INIT - FULL" on the message center.
- 2) Press the <SET> key.

Print Baud Rate

The purpose of **PRINT BAUD RATE** is to set the baud rate of the printer. There are three baud rates that may be chosen. They are 9600, 2400, or 1200.

The Default baud rate is 9600.

To set the baud rate:

- 1) Press the <SET> key until "PRINT BAUD RATE-BBBB" appears on the message center.
- 2) Use the <UP> or <DOWN> keys to choose between 9600, 2400, or 1200 depending on the particular printer in use. (Check printer manual for printer baud rate).
- 3) Press the <SET> key.

BLIND OPERATOR FEATURE

This feature will help assist blind operators in servicing the machine in the pricing menu.

- 1) Set the Universal Control Board DIP switch 1 to the ON position to enable the Blind Operator Feature.
- 2) Close the service door momentarily to restart the **SERVICE MENU**.
- 3) The **SET PRICE MENU** will now initialize to .00 cent each time. It will stop at .00 and \$99.95 while decrementing and incrementing.
- 4) The **PRICE MENU** will now be accessible directly by pressing the middle top gray service key before trying to access the **SERVICE MENUS**.

Section 4

TROUBLESHOOTING

INTRODUCTION

This section contains a preliminary check list, a Power Supply Indicator Light Identification Table and three troubleshooting charts. The first chart lists possible problems and suggested solutions. The second lists Error Messages which will be shown on the Message Display Center when in the Service Mode. And the third lists possible malfunctions with the Refrigeration unit.

When a problem occurs, always look for the obvious solution first. Check the following before attempting to make any adjustment or replace any parts:



Check List

- ✓ Check that the merchandiser is connected to a live power source with a good ground.
- ✓ Check that the main power switch is ON.
- ✓ Check the condition of both circuit breakers on the main power switch assembly, the four circuit breakers on the power supply cover, and the one on the power supply unit behind the center panel of cabinet.
- ✓ Check to insure both interlock switches are actuated when cabinet door is closed and latched.
- ✓ Check that all plugs are seated in their receptacles.
- ✓ Check that connector pins are not bent, broken or pushed through the back of the connector housing when mated.
- ✓ Check that wires are not broken at connector pins.
- ✓ Check all indicator LED's on the UCB and Power Supply Asm.

Indicator Lights

Voltage source problems are indicated by LED indicator lights located on the power supply. A representation of the Power Supply Cover showing the approximate location of these lights is described on page 4 - 8. Below it is a table describing what the indicator lights are monitoring. This will help you quickly isolate most voltage source problems.

Troubleshooting Charts

Each time the Universal Control Board is powered up it performs a series of tests to determine if specific components are functioning properly. As the machine goes through its various cycles during vending there are a number of routines which monitor the machine's performance and record any malfunctions. If a problem is encountered an Error Message indicating the type of problem is stored in the Universal Control Board's memory. The memory is battery backed and will not be affected by routine power outages.

If an error code occurs the machine will attempt to continue to operate normally. It should be noted however, that certain errors will make it necessary to disable some functions.

For example: If the lock bar solenoid fails to lock the doors it would be necessary not to allow the turret to rotate. This would prevent someone from taking out items through the unlocked doors which haven't been paid for.

Error Messages

For a listing of the Error Messages see the *Troubleshooting Chart - Error Messages*, pages 4 - 10 & 4 - 11. To view and clear Error Messages see Service Mode Operation, page 3 - 1.

The 548 has self diagnosing software to identify problem conditions. The operator is alerted using error messages rather than error codes.

If the error occurs while the coin mech door is open (service mode), an immediate temporary descriptive message is displayed. If the error occurs while the coin mech door is closed (vend mode), the error message is added to an error queue. If there are any error messages in the error queue at the start of service mode, they will be displayed in the order in which they occurred. The <SET> key is used to advance to the next message.

After all the messages have been viewed, the operator will be given the option of clearing the message queue. If the queue is not cleared, the error messages will continue to appear each time the coin mech door is opened to start the service mode.

OUT OF SERVICE

When a serious error condition occurs or exists while in vend mode, the machine will be put out of service. If there was credit established at that time, it will be returned. All of the money handling devices will be disabled. The Message Center will display "SORRY-OUT OF SERVICE" and the fluorescent lights will be turned off.

Turret Motor Errors

Upon full initialization, the turret motor zero position is reset and needs to be located. The zero position is indicated via the activation of a magnetic switch mounted on the main door by a magnet mounted on the turret. The main door must be closed to find zero position. The zero position will also need to be found if any motor error occurs either in vend mode or service mode.

NOTE:

Each time the machine is turned ON, the turret will rotate until zero position is located. An error message will be generated if the zero position cannot be located.

If the error occurred in vend mode, the machine will be put out of service, the motor will be disabled and the error message will be inserted into the error queue.

If the error happens while in service mode a temporary error message will be displayed. Another temporary error message will appear each time the turret motor is turned until zero position is located again. This can be done in the Diagnostic Menu.

If a motor error occurred while the service switch is on, the temporary message will be displayed and the motor will be stopped. To restart the motor, the service switch must be turned off and then on again.

COIN MECH PROBLEMS

The coin mech is required for machine operation in vend mode except when free vend is active. Upon power up and each time the coin mech door is closed, the reset line on the coin mech is toggled which results in the coin mech sending a power-up message to the UCB. If that message is not received in the specified time period, the "COIN MECHNO REPLY" message will be displayed. The machine will be put out of service if this occurs in vend mode. The probable cause of this error is that the coin mech is not plugged in. During service mode, the coin mech is enabled at all times and coins should be accepted. If coins are not being accepted, make sure the coin mech is receiving power from the power supply by pressing the coin payout buttons and listening for the solenoids energizing. If no solenoids are energized, then examine the power connections in the coin mech harness. If the solenoids do energize but the coin mech is not accepting coins in service mode, examine the accept-enable connections in the coin mech harness.

INITIAL POWER UP

Upon power up, the column display should show:

11111
 22222
 33333
 44444
 55555
 66666
 77777
 99999
 AAAAA
 bbbbb
 CCCCC

The displays will remain unchanged until the Universal Control Board sends them messages. If any of the column display tubes fail to "light up" the column display harness should be tested to ensure that power is being supplied.

The Message Center will display a "KEYPAD-DISPLAYVX.X" message upon power up. The display will remain unchanged until the Universal Control Board sends it a message. If the Message Center fails to "light up" the Message Center harness should be tested to ensure that power is being supplied.

When the UCB software starts up, it sends a 548 software revision identification message to the Message Center for a few seconds. The display should then change to service menu, assuming that the coin mech door is still open. The column display will then receive the compartment prices.

The Test LED on the Universal Control Board will begin to flash indicating that the processor is running. In general, the LED should always be flashing; though there are times when it will stop flashing momentarily during certain normal processing.

If the power up message of either display remains after the UCB Test LED begins flashing, then there is no communication between the UCB and that display and the harness should be examined.

Power-Up Initialization

The UCB features 8 Kbytes of battery backed up RAM enabling the software to "remember" the state of the 548 if power is interrupted for any amount of time.

The advertised approximate life of this battery is 10 years. When power to the machine is restored, the prices, options, MIS information etc. are the same as when the power was lost.

Each time the UCB is powered up, two tests are executed to determine if initialization is necessary. One test examines two memory locations for a specific test pattern. The other test performs a memory checksum calculation on most of the code section of UCB EPROM. If either test fails, a full software initialization will take place. This should occur each time a new EPROM is installed.

After initialization, all options are disabled, MIS information is cleared, the prices are set back to default etc. The default prices for schedule one are \$99.95 for all shelves. The prices for schedules two and three start at 5 cents and increment by 5 cents starting at shelf A, schedule two and ending at shelf K schedule three.

The operator may also manually initialize the machine via the Default service menu. There are two selectable types of initialization available; options and full. The options initialization will initialize all the options found in the Options menu to their default state. **The full initialization will work as described above except that the nonresettable MIS totals will not be cleared.**

REFRIGERATION SYSTEM

If the refrigeration system compressor is inoperative, perform the following checks before replacing the unit. Be sure to hold the Refrigeration Interlock Switch closed when making the operational checks.

NOTE:

When the refrigeration door interlock switch is depressed, a one minute power up delay to the compressor circuit will occur.

1. Measure the line voltage. If line voltage is below 105 volts, the compressor may fail to start, or run hot.
2. If line voltage is correct, check automatic control thermostat operation by connecting a jumper wire across the terminal with power disconnected.
3. The Start Capacitor, Run Capacitor, and Start Relay are best tested by substituting them with known good components. This way there can be no doubt of test results.
4. Check Thermal Overload for continuity.
5. With motor leads disconnected from circuits, check compressor motor windings with Volt/Ohm meter set on R x 1 scale.

(Readings +/- 10%)

Common to Start 5 Ohms
 Common to Run 1 Ohm
 Start to Run 6 Ohms

6. Check for grounded winding with Volt/Ohm meter from Start Capacitor to metal casing and Run Capacitor to metal casing. There should be no continuity, if there is, replace compressor.

COMPRESSOR CIRCUIT DESCRIPTION

The Compressor Motor is a Two Value Capacitor Motor. This is very similar to a Permanent Split Capacitor Motor except for the addition of a Running Capacitor. During start-up, both the Running and Starting Capacitors are in the circuit. This makes the total Capacitance during start between

98 FD and 113 FD. Once the Motor is running the capacitance is reduced to 25 FD.

The overall effects of a Running Capacitor are:

- Increases break down torque 30%
- Reduces full-load current
- Reduces full-load noise
- Increases locked rotor torque 20%
- Increases overall efficiency

The Start Relay contact is normally closed. The Start Relay has a voltage sensitive coil that remains de-energized until the voltage across its coil, caused by the voltage across the Start Winding, exceeds 162-175 VAC. At this time the compressor has broken away from the load and is near its nominal running speed. As the Compressor shaft speed increases, the voltage on the Start Winding also increases. When the Start Winding voltage reaches the proper level the Start Relay coil will energize. This opens the contacts to the Start Capacitor, disconnecting it from the circuit. With the Start Capacitor disconnected, the current through the Start Winding will drop 70%. The Bleeder Resistor provides a safe discharge path for any stored charge in the Start Capacitor. Failure to return the Start Relay and the Control Box to their correct mounting position will cause the motor starting voltages to be altered. This could result in start-up problems at low line voltages.

Always secure the Control Box before returning the unit to service.

The table below lists the DC resistance of components used in this merchandiser. If the troubleshooting chart indicates a motor or a solenoid malfunction, test the coil with an ohmmeter as instructed below.

TABLE 4 - 1 Component Resistance

Description	Resistance (OHM +/- 10%)	Part No.
Door Latch Solenoid	9 Ohms Reverse meter leads for approximately .2 Ohms difference	548-1857
Lock Bar Solenoid	4.8 (Diode in place) Reverse meter leads for approximately .2 Ohms difference	548-1854
Transport Motor	10 Ohms	548-1815

CAUTION!

This is a HIGH Energy Circuit. DO NOT use less than 16 gauge wire or switches rated less than 15 amps. DO NOT connect the jumper wire or switch while power is ON.

When power is applied to the black wire, the Evaporator Blower should run immediately. Connecting the black wire to the YL/BK wire closes the refrigeration circuit. When the YL/BK wire is made hot, the condenser fan and compressor will start to run. Until the compressor rotor shaft reaches a minimum running speed, the start relay contact (Terminal 1 & 2) will remain closed. This allows the start capacitor to draw high current through the

start winding. This creates a high torque at the rotor shaft in order to accelerate the Compressor under load. As the rotor comes up to speed, the voltage on the start relay coil (Terminals 2 & 5) will rise. When the minimum running speed is attained, the Start Relay coil will energize and open the circuit to the Start Capacitor. When repairing the refrigeration unit only use EXACT replacement parts for the Start Relay, Run and Start Capacitors. Failure to do so will void the warranty. Please note the placement of the Start Relay and the Control Box. Both must be returned to the proper orientation. Altering the mounting position for either of these parts will change the starting voltage. Relay, Run and Start Capacitors.

Backup Refrigeration Unit

Normal Operation:

1. The UCB provides a pulse output at J11 pin 2 when controller is OK.
2. The UCB sends out a PULSE signal along with VRTN and +24VDC to be monitored by the DM TIMER circuit board.

If all outputs are healthy, the backup relay is held energized. This keeps the refrigeration system operated by the UCB which controls the refrigeration relay with outputs VRTN and VREFRIG.

Backup Operation:

If one of the following symptoms occur, the DM TIMER will drop out causing transfer of the refrigeration circuit through the Cold Control Thermostat.

1. If missing PULSE from the UCB for approximately 10 minutes.
2. If missing +24VDC or VRTN, the DM TIMER would immediately loose its +24 and RNSNK outputs..
3. If temperature in the cabinet is above 80° F, the UCB will stop sending pulses until the teperature drops below 80° F.

When the DM TIMER has dropped out, the backup relay coil will de-energize, and transfer the refrigeration circuit through the Cold Control Thermostat.

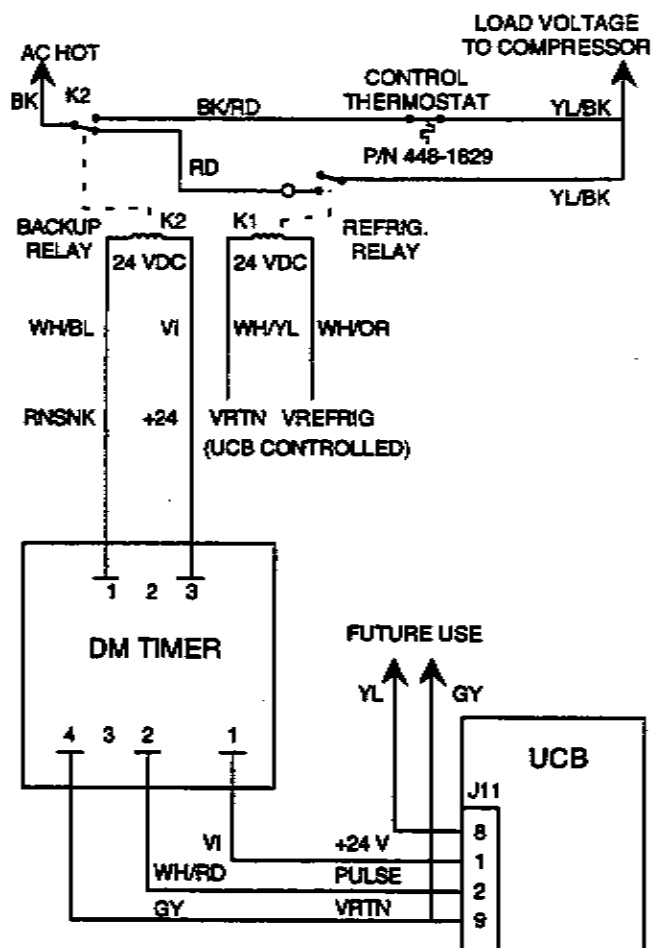

Figure 4-1
Backup Refrigeration Schematic

Refrigeration System Wiring Diagram (Domestic)

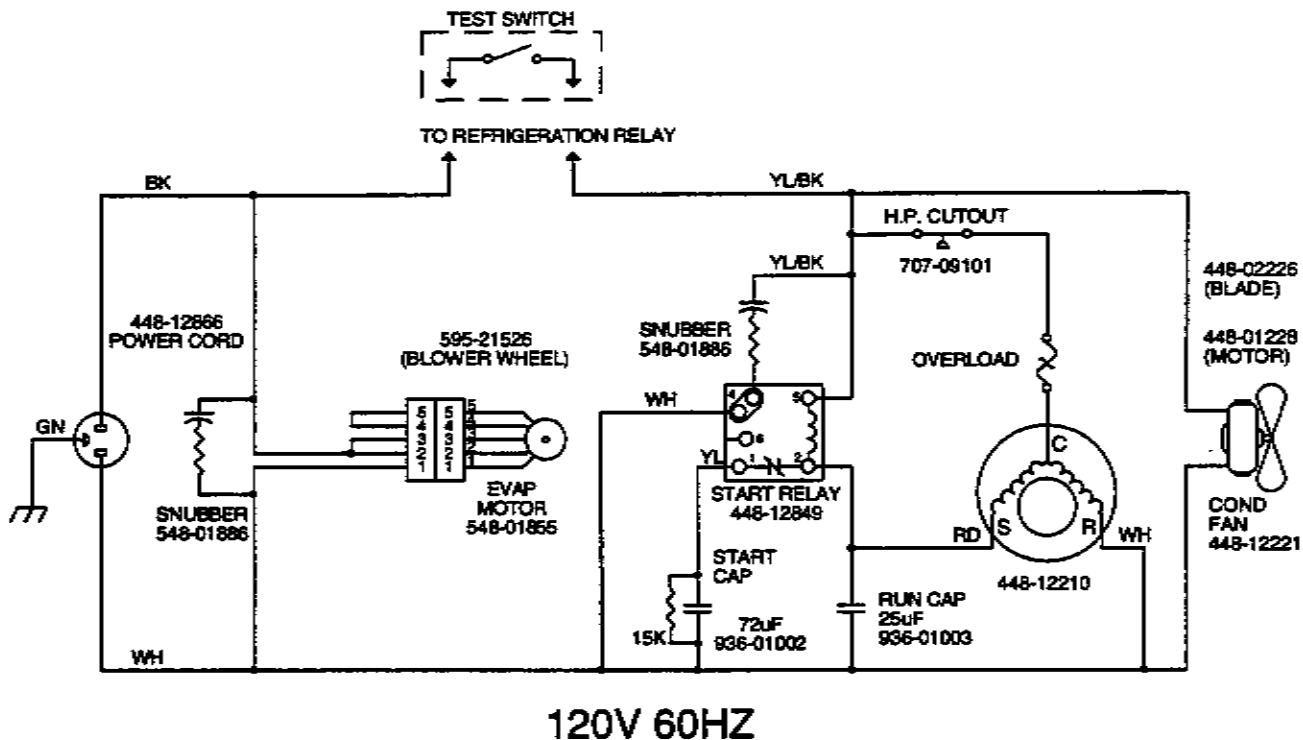

Figure 4-2. Refrigeration Wiring Diagram (Domestic)

NOTE:

The entire Refrigeration Unit may be removed from the vendor and run on the bench to troubleshoot. Install a jumper wire capable of handling 10A (16 gauge) in the Refrigeration Relay harness connector and plug the power cord into 120V grounded receptacle. Do not allow unit to run for extended periods of time without the Cold Control. It could cause the Evaporator to freeze.

CAUTION !

Protective eye wear must be worn when testing refrigeration systems. This system is charged with 18oz. of 404a refrigerant. Repair should only be performed by technicians trained and experienced in refrigeration troubleshooting and safety procedures. Never introduce other refrigerants into this system. Operating temperature/pressure will be affected and the unit will not function properly and could be destroyed.

Refrigeration System Wiring Diagram (European)

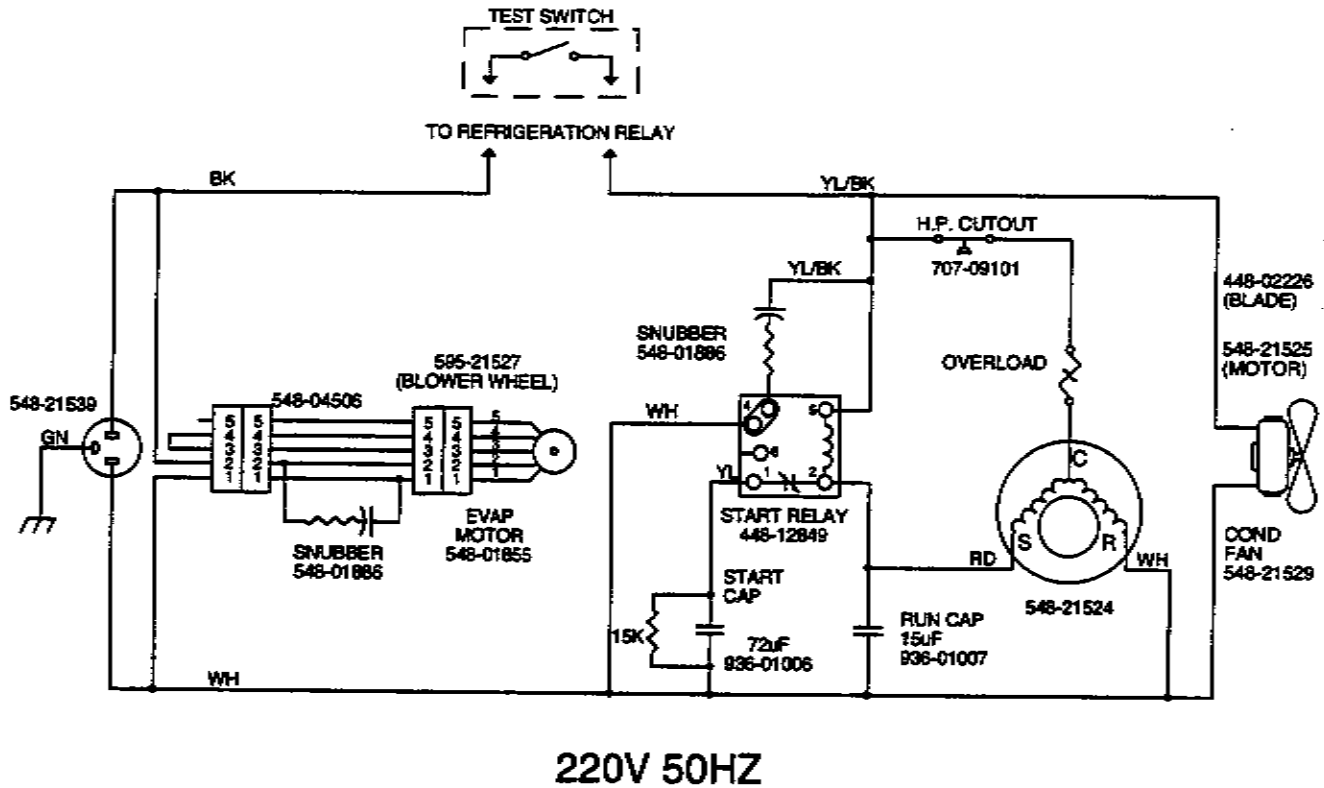

Figure 4-2. Refrigeration Wiring Diagram (European)

NOTE:

The entire Refrigeration Unit may be removed from the vendor and run on the bench to troubleshoot. Install a jumper wire capable of handling 10A (16 gauge) in the Refrigeration Relay harness connector and plug the power cord into 220/240V grounded receptacle. Do not allow unit to run for extended periods of time without the Cold Control. It could cause the Evaporator to freeze.

CAUTION !

Protective eye wear must be worn when testing refrigeration systems. This system is charged with 18oz. of R404a refrigerant. Repair should only be performed by technicians trained and experienced in refrigeration troubleshooting and safety procedures. Never introduce other refrigerants into this system. Operating temperature/pressure will be affected and the unit will not function properly and could be destroyed.

Power Supply Indicator Lights

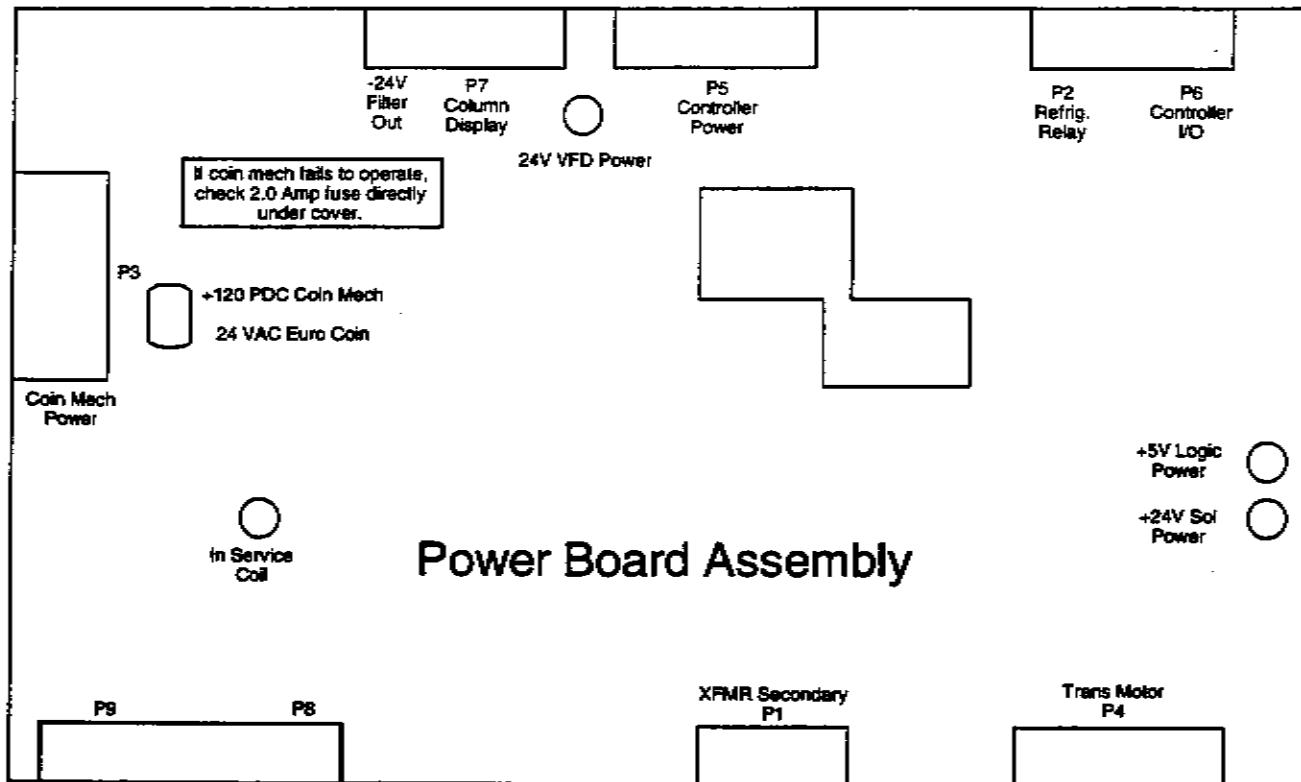

Figure 4-4. Power Board Assembly Indicator Lights

Name	Color	Description
+120 V PDC Coin Mech	Neon	120 V Pulse DC for Coin Mech
27 VAC Euro Coin	Yellow LED	27 VAC for European Executive Coin Mechs and Card Systems.
In Service Coil	Red LED	ON Indicates that the Fluorescent Lamp Relay Coil is energized.
-24V Fil. Out	Red LED	On indicates that the Column Display Filament Voltage is present.
+24V VFD Power	Red LED	On indicates that the -24V Cathode Supply is present. This is used to power the Column Display Message Center.
+5V Logic Power	Red LED	ON Indicates the presence of the +5 VDC Logic Supply.
+24V Solenoid Power	Red LED	ON Indicates the presence of the +24V Solenoid Supply.
Refrig Relay	Red LED	ON indicates power output to energize the refrigeration relay.

Coin Mechanisms

120V Models - 12 or 15 Pin

MARS TRC - 6000

COINCO 9300L

24V Models - 15 Pin Only

MARS TRC - 6010 - XV

COINCO 9302LF

CAUTION !
Do not use a 24 volt Coin Mech with a 12 pin plug. This will result in permanent damage to the Coin Mech and / or the vendor.

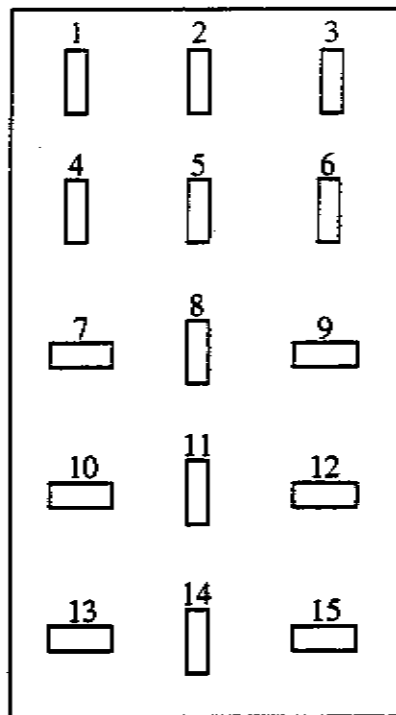

- 1. +5 VDC
- 2. 5V RTN
- 3. Send
- 4. Int.
- 5. Data
- 6. Accept Enable
- 7. Dis \$.25
- 8. Dis \$.10
- 9. Dis \$.05
- 10. -120V PDC
- 11. Reset
- 12. +120V PDC
- 13. -24V PDC
- 14. Dis \$1
- 15. +24V PDC

**15 Pin
Coin Mech Socket**

Figure 4-5. 15 Pin Coin Mech Socket

Troubleshooting Chart Error Messages

ERROR MESSAGE	PROBABLE CAUSE	SOLUTION
"MOTOR MALFUNCTION"	Turret Motor jammed error, return to zero position	Clear jam, clear motor
	Turret overloaded	Same as above
	Shorted motor leads	Remove short, clear error, turn to zero position
	Bad driver circuit on Power Supply	Replace power supply
	Bad detection circuit on Power Supply	Replace power supply
"HEALTH TIME EXPIRED"	Refrigeration unit not plugged in	Check and replug
	Refrigeration screen on condenser clogged	Check and clean
	Refrigeration relay disconnected or defective	Check and/or replace
	Machine too close to the wall	Move away from wall at least 6"
	Main door not closed tightly	Check and readjust latches
	High ambient temperature	Vendor not designed to operate outside
	Temperature reads 96° F continuously	Temperature Sensor not plugged in, or defective
Faulty refrigeration system	See pages 4 - 3, 4 - 4, 4 - 5, 4 - 15 and 4 - 16	
"MAIN DOOR OPEN"	Switch not activated	Check Main Door and switch adjustment
	Switch broken or defective	Replace switch
	Switch disconnected	Check wiring

Troubleshooting Chart Error Messages Continued

ERROR MESSAGE	PROBABLE CAUSE	SOLUTION
"HALF CYCLE SWITCH"	Half Cycle Switch disconnected or defective	Check wiring at Half Cycle Switch Replace Switch
	Motor Interlock Switch disconnected or defective	Check wiring at Motor Interlock Switch Replace Switch
	Half Cycle signal to Controller disconnected or defective	Check I/O Cable between Power Supply P6 to Controller board P6
	Logic circuit on Power Supply defective	Replace Power Supply Asm.
	Inline fuse to motor opened	Replace Fuse Check F4 (PICO fuse) on P/S (P/S 548-1860 Only)
"ZERO POSITION ERROR"	Unable to locate zero position	Check Zero Position Switch, wiring, and magnet
	Machine initialized, no zero position located	Same as above
	Possible Motor Error	Check Motor wiring connections
	UCB unable to monitor turret movement	Check Half Cycle Switch on motor
"LOCKBAR SOL ERROR"	Defective Driver on UCB	Replace UCB
	Defective Power Supply	Check power supply for 24 VSOL lamp
	Bad lockbar solenoid wiring	Check wiring for lockbar solenoid
	Defective Solenoid	Replace Lockbar Solenoid
"LOCKBAR SWITCH ERROR"	Bad lockbar switch	Check lockbar switch wiring Replace Switch
"DEFECTIVE SENSOR MSG"	Defective coin tube sensor	Check Coin Mech Replace Coin Mech
"COIN JAM MSG"	Coin lodged between acceptance gates.	Check and clear jam Clean Flight Deck Replace Coin Mech
"NO STROBE MSG"	Valid coin has been recognized but not detected passing through to the inventory tubes or to the cash box.	Check for blockage in Coin Mech Replace Coin Mech Check payout switches for operation. If not operating, Check P/S 120VPDC LED. If out replace F1 fuse on power supply board.
"COIN MECH NO REPLY"	Coin mech unplugged or defective coin mech	Check Coin Mech Connection Replace Coin Mech
"BAD TEMP PROBE"	5VDC line to temp probe open	Check red wire connection at probe and P9 of the UCB. Check continuity between P9 pin 2 (red wire) to interconnect of temp. probe. If Okay, replace probe.

Troubleshooting Chart (Problem / Solution)

PROBLEM	PROBABLE CAUSE	SOLUTION
Message Center does not light	No power to the Message Center	Check for +5 VDC Check for VRTN Above voltages are required for the Message Center to light. There is only one cable to the Message Center. This comes from the Controller Board. If the Controller dies but power is still on the Message Center, the Message Center will default to the built in message "KEYPAD-DISPLAY VX.X"
	Price Column display does not light	Missing Power Harness/Connector Problem Defective Column Display
Does not accept coins	Missing Power	Check Power Supply 120 PDC Light Indicator
	Harness/Connector Problem	Check Coin Mech Socket, UCB (P8) and P/S (P3)
	Defective Coin Mech	Replace
Does not attempt acceptance	Missing Power	Check power light on Power Supply
	Coin Mech change level low	Add change to Coin Mech
	Improper coin loading technique	See Coin Loading routine page 2 - 2
	Harness/Connector Problem	Check I/O UCB (P5) to B/A (P2 - P3)
	Bill Acceptor not enabled	Check Options Menu program on page 3 - 19 to see if B/A is enabled
	Defective Bill Acceptor	Replace

Troubleshooting Chart (Problem / Solution)

PROBLEM	PROBABLE CAUSE	SOLUTION								
Does not register credit	Credit messages not received from Coin Mech	No continuity between J8 pin 9 of UCB and pin 5 of Coin Mech plug								
	Coin Mech defective	Replace Coin Mech								
	Service Door switch not closed	Check for defective actuator								
Does not give change	Coin Mech mis-programmed	Reload Coin Mech. See page 3 - 10 Set Coin Tubes								
	Dispense lines to Coin Mech disconnected	Check continuity between: <u>Controller J8</u> <u>Coin Mech</u>								
		<table style="margin-left: auto; margin-right: auto;"> <tr> <td>pin 3</td> <td>pin 9</td> </tr> <tr> <td>pin 4</td> <td>pin 8</td> </tr> <tr> <td>pin 5</td> <td>pin 7</td> </tr> <tr> <td>pin 7</td> <td>pin 14</td> </tr> </table>	pin 3	pin 9	pin 4	pin 8	pin 5	pin 7	pin 7	pin 14
	pin 3	pin 9								
pin 4	pin 8									
pin 5	pin 7									
pin 7	pin 14									
Defective controller board	Replace controller board									
Dollar coins in MIS	Empty dollar coins									
Turret does not rotate	Harness/Connector problems	Check terminals on Motor Check P/S (P4) BK/OR & BL/OR wires to motor terminals Check UCB (P6) to P/S (P6) Check UCB (P2) to Message Center								
	No signal from Message Center	Replace defective Message Center								
	UCB ON/OFF output signal missing	Measure P/S (P6 pin 11) to (P5 pin 2 ground) for 12 VDC with Service Switch ON Replace UCB if missing voltage								
	Turret overload or jammed	Replace P/S if voltage is present								
	DC Motor defective	Remove obstruction Check for 24VDC across motor, if present, replace. If not, check in-line fuse. Check F4 (PICO Fuse) on P/S. (P/S 548-1868 Only)								
Turret only turns one direction	Key Stuck on Message Center	Disconnect harness. If turret stops replace Message Center								
	Service Switch defective or shorted to door	Check Switch Perform continuity test between switch and door chassis for wire short								

Troubleshooting Chart (Problem / Solution)

PROBLEM	PROBABLE CAUSE	SOLUTION
Turret only turns one direction	UCB Dir output signal missing	Measure across P/S (P6 pin 9) to (P5 pin 2 ground) for 12 VDC Replace UCB if missing voltage Replace P/S if voltage is present
	Harness/Connector problems	Check UCB P6 to P/S P6, BL/BK wire for continuity
	Message Center Rocker Sw. defective	Replace message Center
Turret stops between lobes on cam	Defective power supply	Replace power supply
Turret Rotates constantly	Key stuck on Message Center	Disconnect harness from Message Center, if turret stops replace Message Center
	Service Switch defective or shorted to door	Check Switch Perform continuity test between switch and door chassis for wire short
	Half cycle switch defective, or wiring defective or unplugged.	Check switch for adjustment and wiring for continuity
Vend Door does not open	Turret out of position and/or in FIFO Mode	Check Turret position Set Zero Position routine in the Diagnostic Menu. Reprogram Shelf Mode
	Compartments in sold condition	Rotate the Turret one full revolution with inside Service Switch Check the Sold Out Check program in Options Menu. See page 3 - 19
	Invalid section lockout	Check the Prohibit Vend Program in Options Menu. See page 3 - 22 Check Solenoid resistance Table 4 - 1. See page 4 - 4

Troubleshooting Chart Refrigeration

PROBLEM	PROBABLE CAUSE	SOLUTION
Vend Door does not open	Defective solenoid	Replace Solenoid
	Defective door switch	Replace Switch
	Missing VSOL from Power Supply	Check P/S +24 VSOL POWER indicator light. Replace Power Supply
	Defective solenoid driver on UCB	Replace UCB
Health Control shutdown	Temperature Probe defective	Press the <BLANK> then <F> key to display temperature. If actual temperature is different from display, replace Temperature Probe
	Evaporator Freeze up	Make sure unit is level
	Refrigeration problem	See following Troubleshooting problems
Refrigeration inoperative	Refrigeration unplugged or no power	Check and replug
	Refrigeration relay unplugged	Connect Refrigeration relay
	Refrigeration overload	Clean screen and condenser coils
	Relay (control) defective	Perform the following: Power Unit OFF. Short together the (blk) and (blk/y) wire on the Refrig. Relay Power Unit ON If (A & B) hold true, replace the Refrigeration Relay: A. (Power Supply Asm.) Refrig. Relay lamp is lit. B. Refrigeration Unit now powers up.

Troubleshooting Chart Refrigeration

PROBLEM	PROBABLE CAUSE	SOLUTION
Compressor does not start	No voltage on (bk) wire with Evaporator/Blower not running	Defective Refrigeration Unit line cord
	No voltage on (yl/bk) wire	Check and/or replace Refrig. Relay
	Low line voltage	Check voltage. It should be 105V minimum with Compressor running
	Start Relay contacts defective	Replace Start Relay
	Motor overload defective	Check and replace
	Start Capacitor defective	Check and replace
	Compressor Head load too high	Allow 3 minutes off time for pressure equalization before restarting and performing pressure checks
Compressor runs hot, trips overload	Compressor Start winding defective	Perform Compressor Ohm test. See page 4 - 3 of (Refrigeration System), if fails test, replace Compressor, Start Relay, Start Cap and Run Cap
	NOTE: Motor will start with Run Capacitor removed or open.	
	Air intake screen clogged or obstructed	Clean as necessary
	Condenser coils blocked	Clean as necessary
	Condenser fan not running	Remove obstruction or replace
	Start Relay not opening, defective	Check and replace
	Run Capacitor not in circuit	Check and install
	Run Capacitor defective	Check and replace
	Low line voltage	Check voltage. It should be 105V minimum with compressor running.
	Low refrigerant charge	Allow 3 minutes off time for pressure equalization before performing pressure checks.

This page intentionally left blank.

548 Showcase Merchandiser

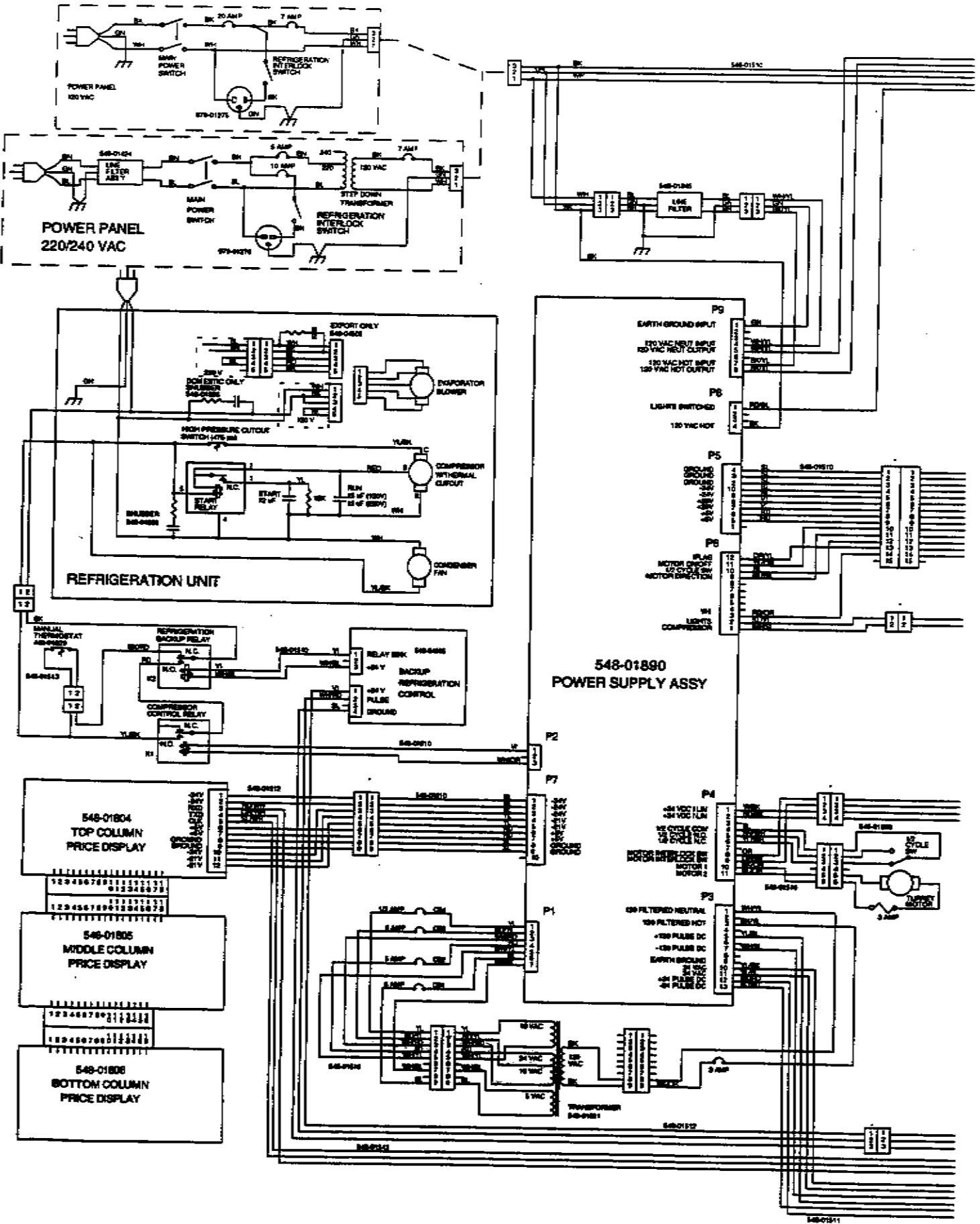

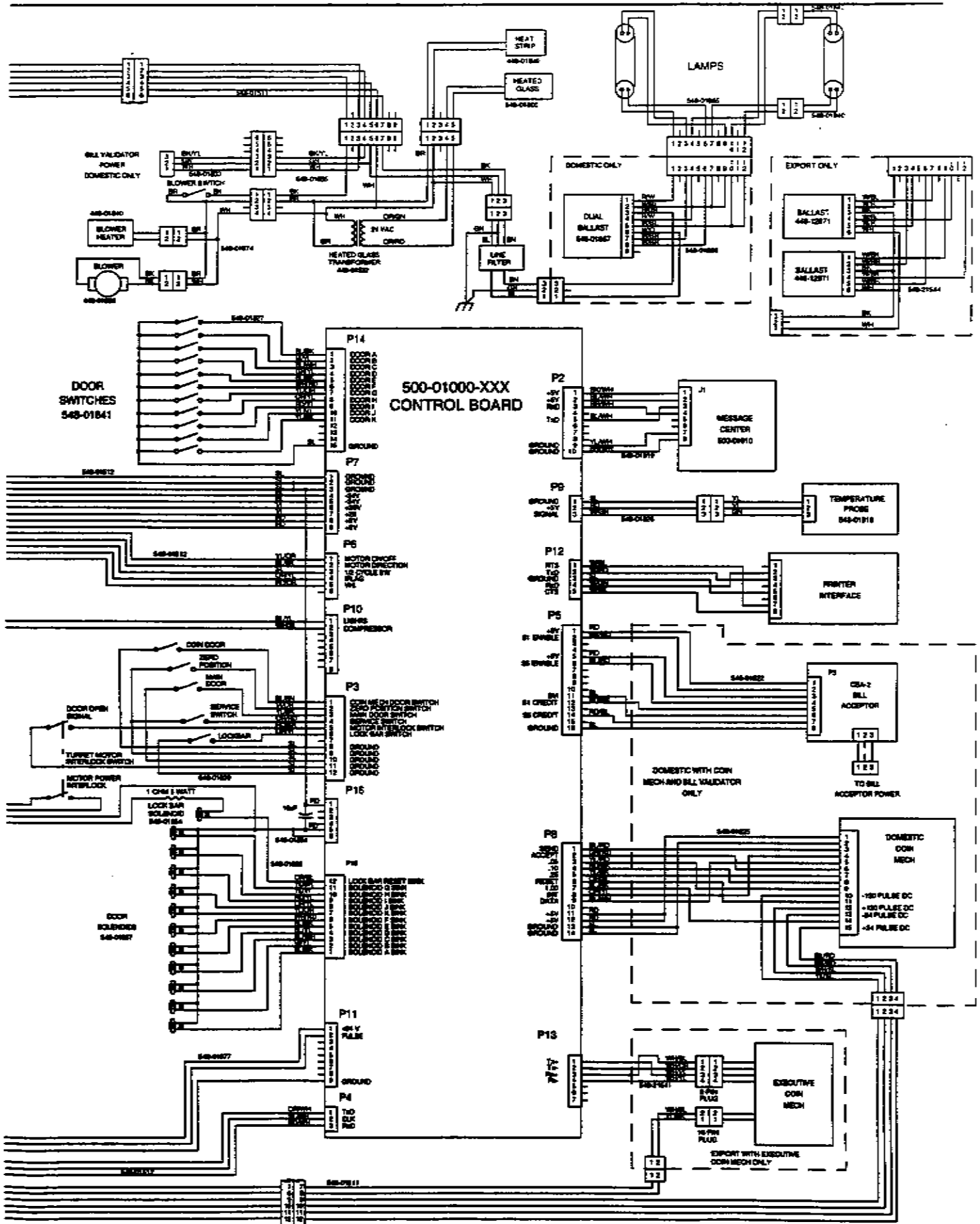

NOTE: * Denotes door interface connector

For Equivalent Engineering Drawing, See 900-54821
Figure 4-6. 548 System Schematic

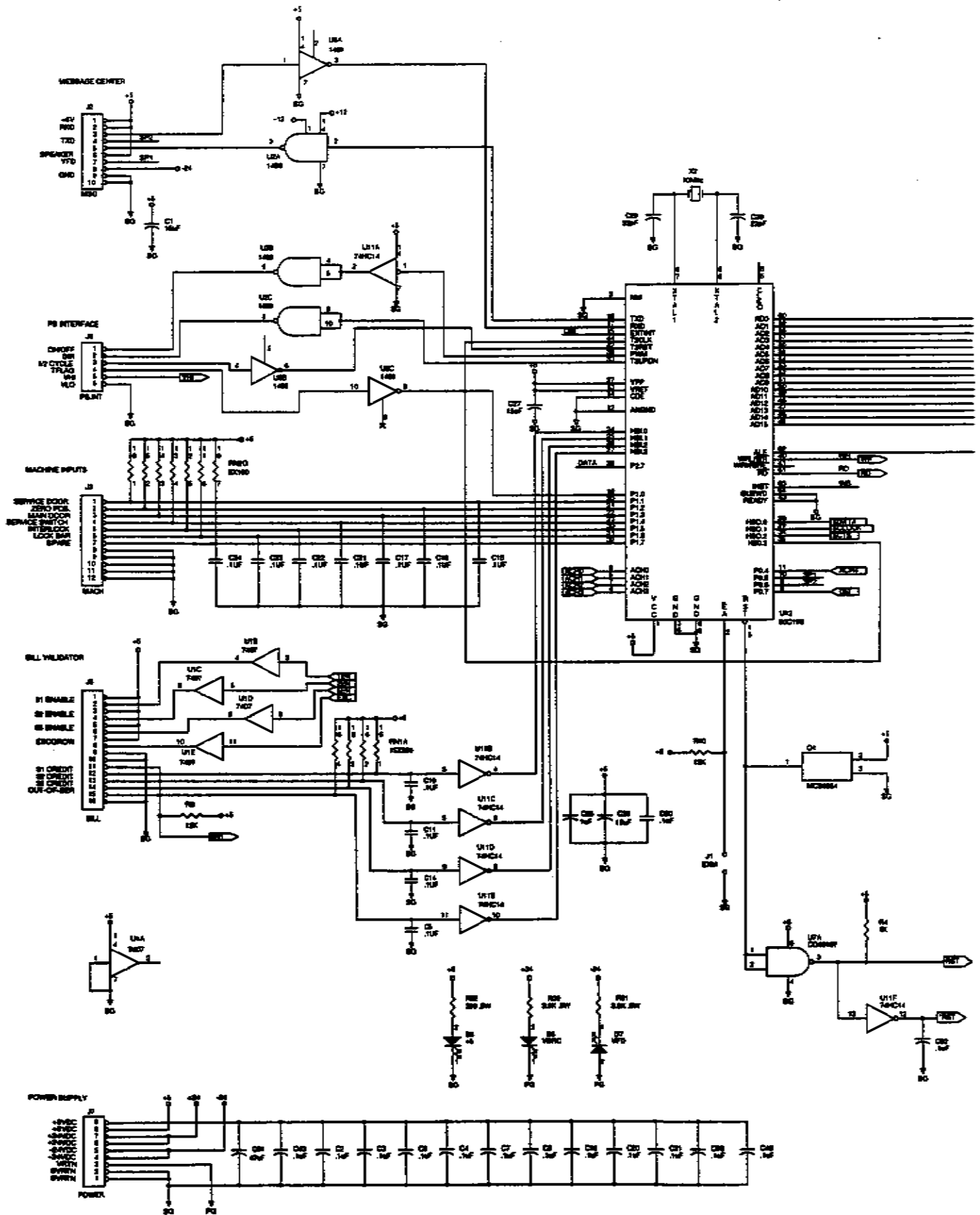

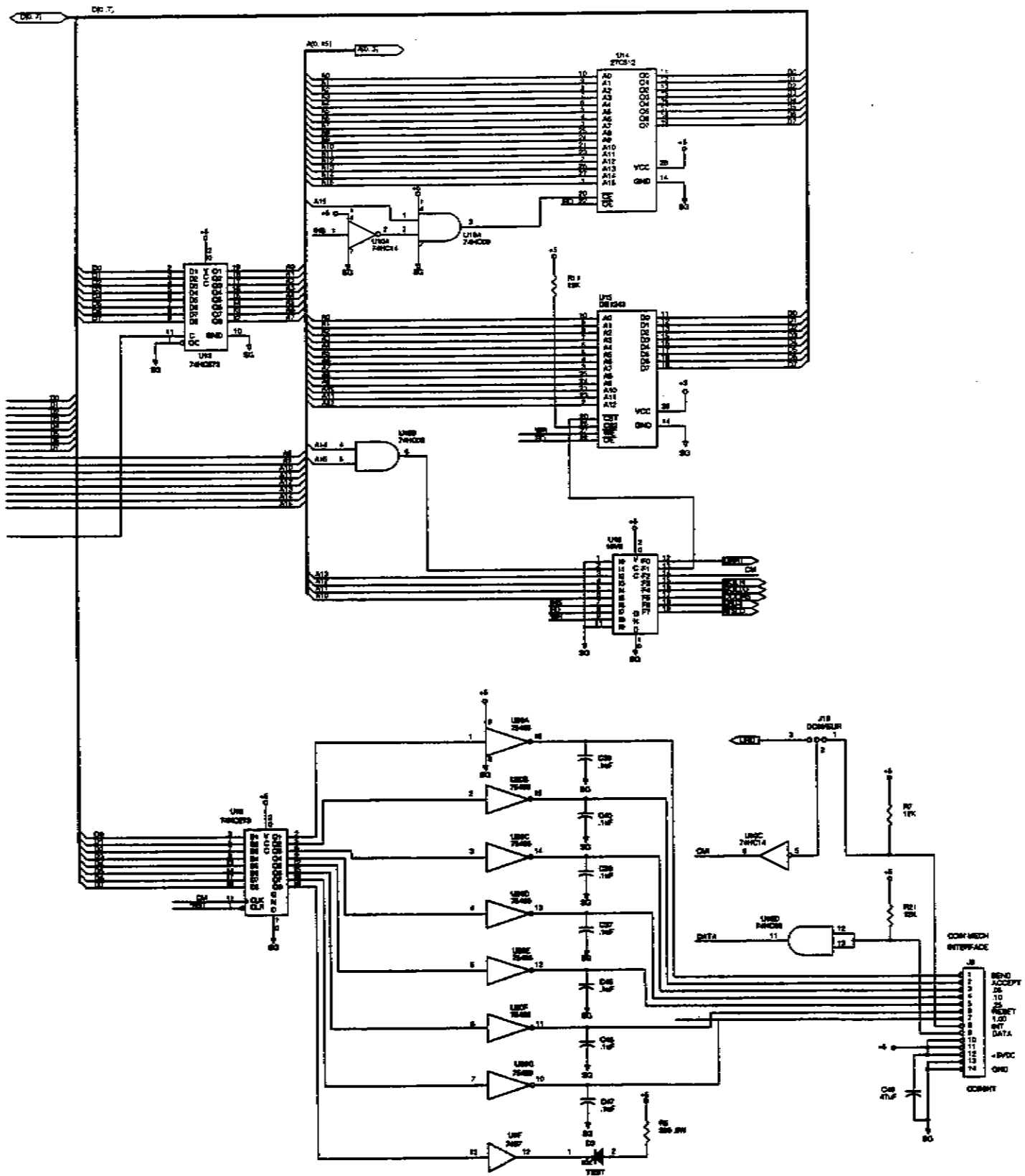

For Equivalent Engineering Drawing, See 28029500 D
Figure 4-7A. Controller Board Schematic, Sheet 1

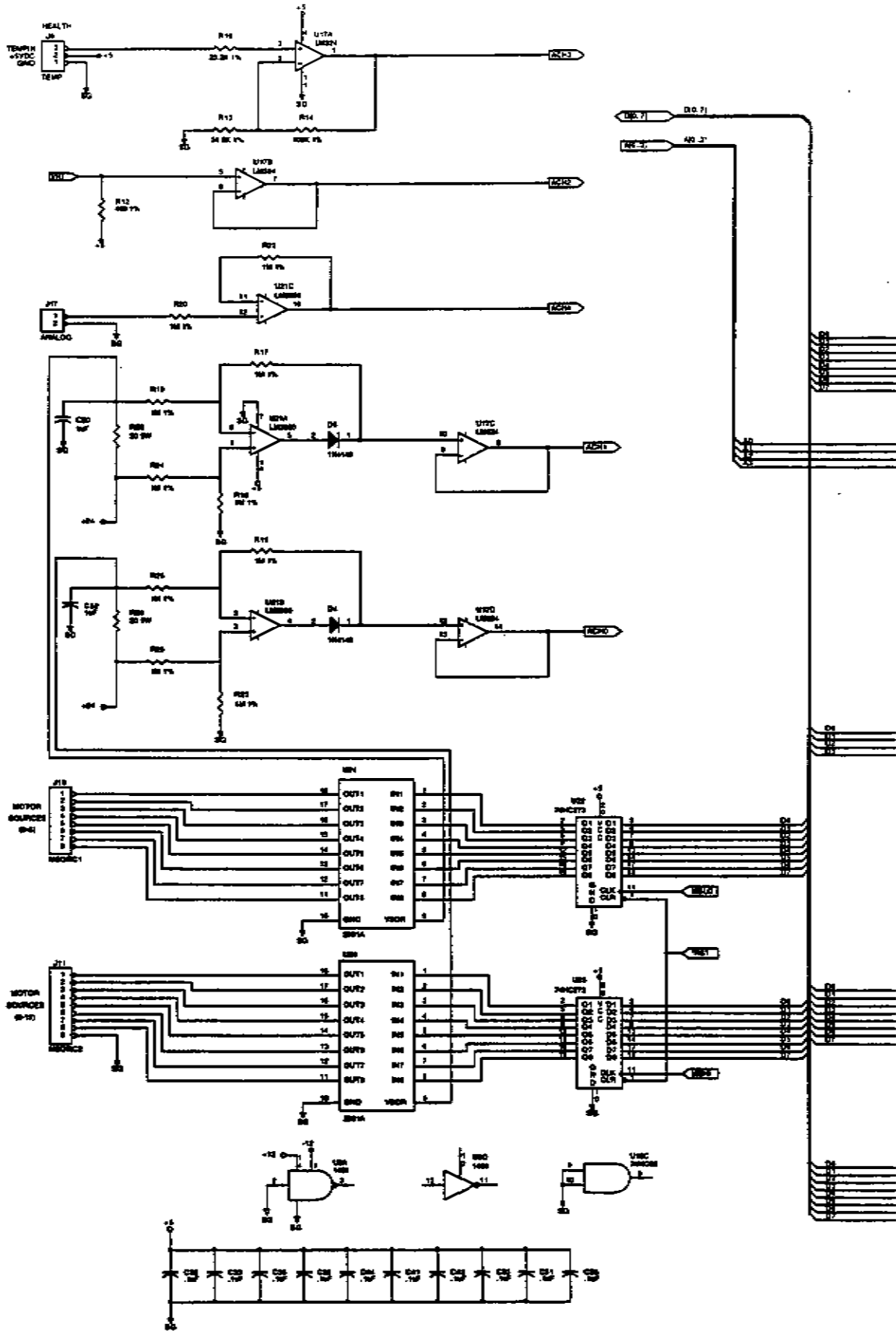

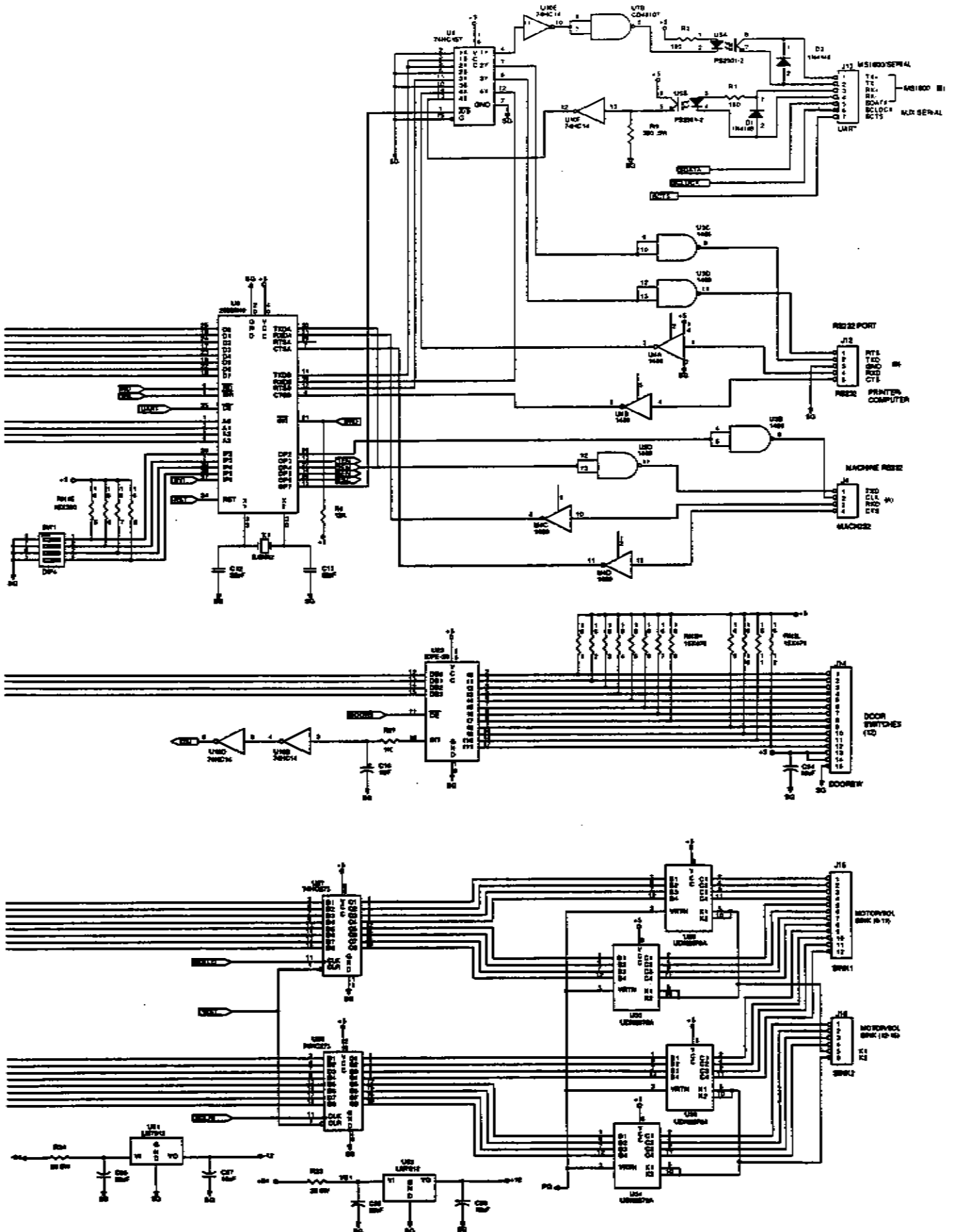

For Equivalent Engineering Drawing, See 28029500 D
Figure 4-7B. Controller Board Schematic, Sheet 2

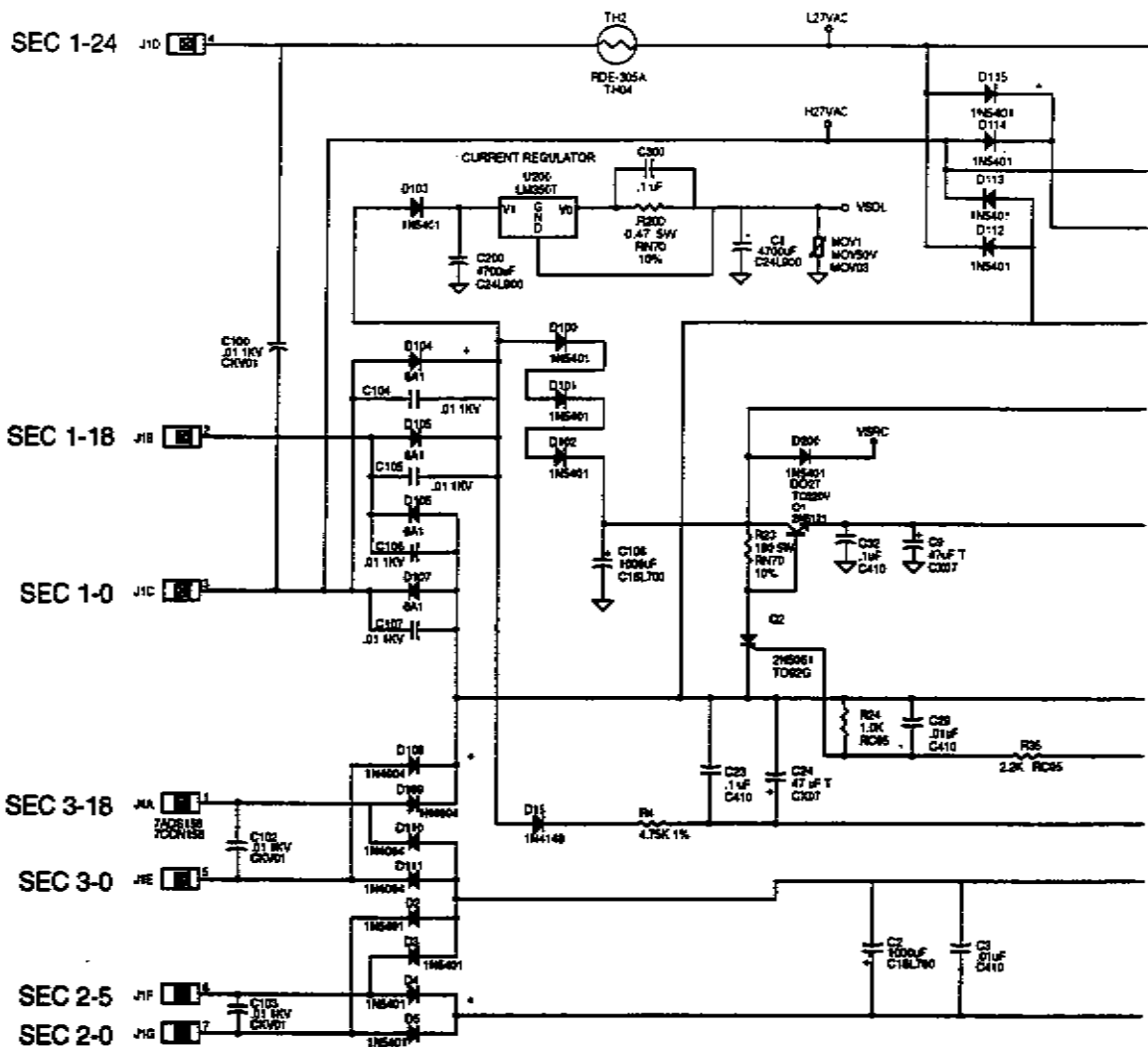

TO XMFR

REFRIG RELAY

VRTN

TO MOTOR

MOTOR 1

MOTOR 2

DOOR INT NC
DOOR INT COM

TO DOOR

1/2 CYCLE NC
1/2 CYCLE NO
1/2 CYCLE COM

VSOL

VLOCK

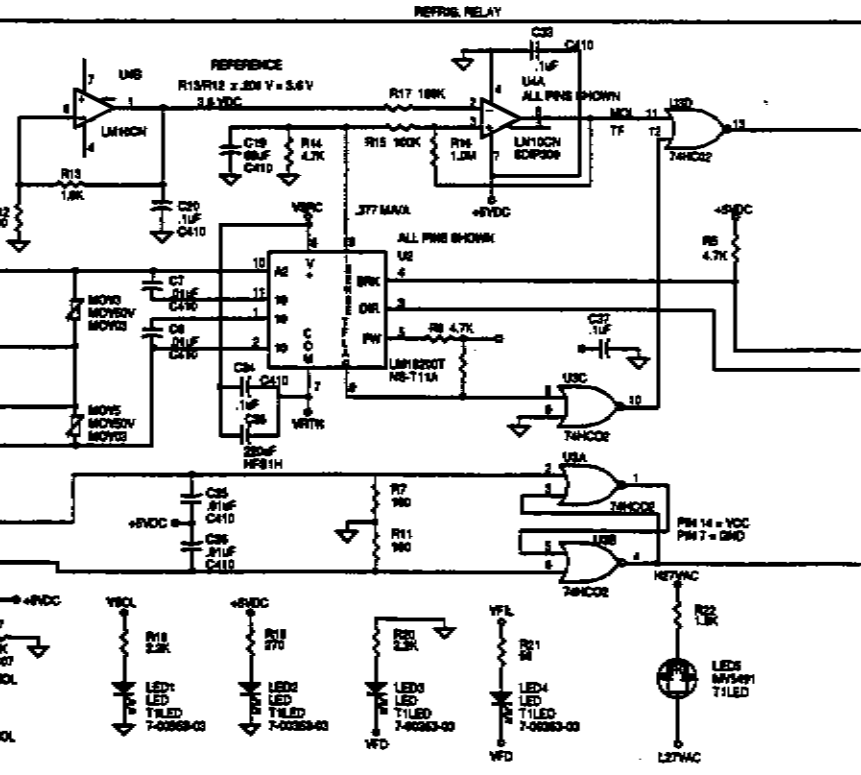

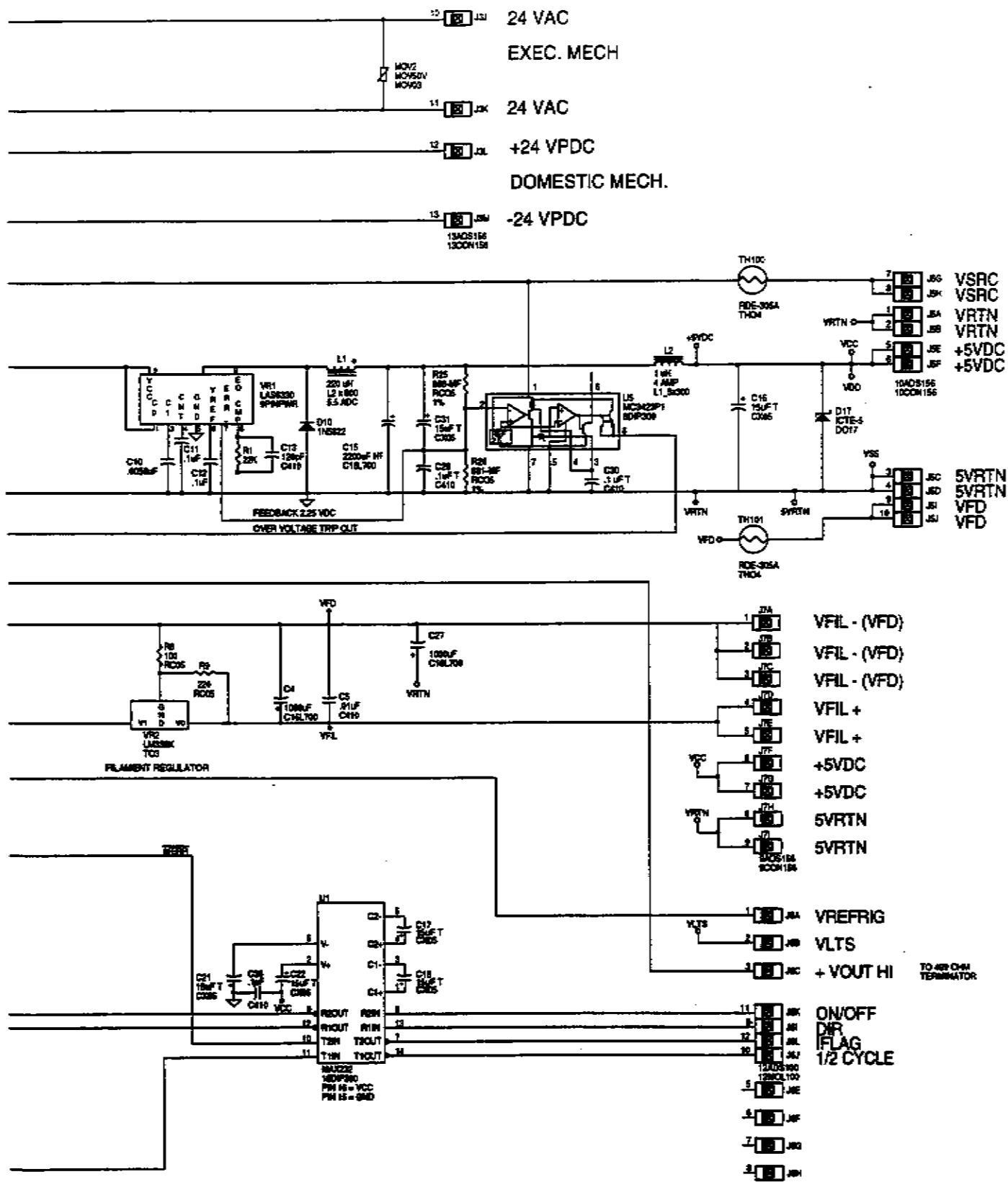

For Equivalent Engineering Drawing, See 28044700 B
Figure 4-8A. 548 Power Supply Schematic, Sheet 1

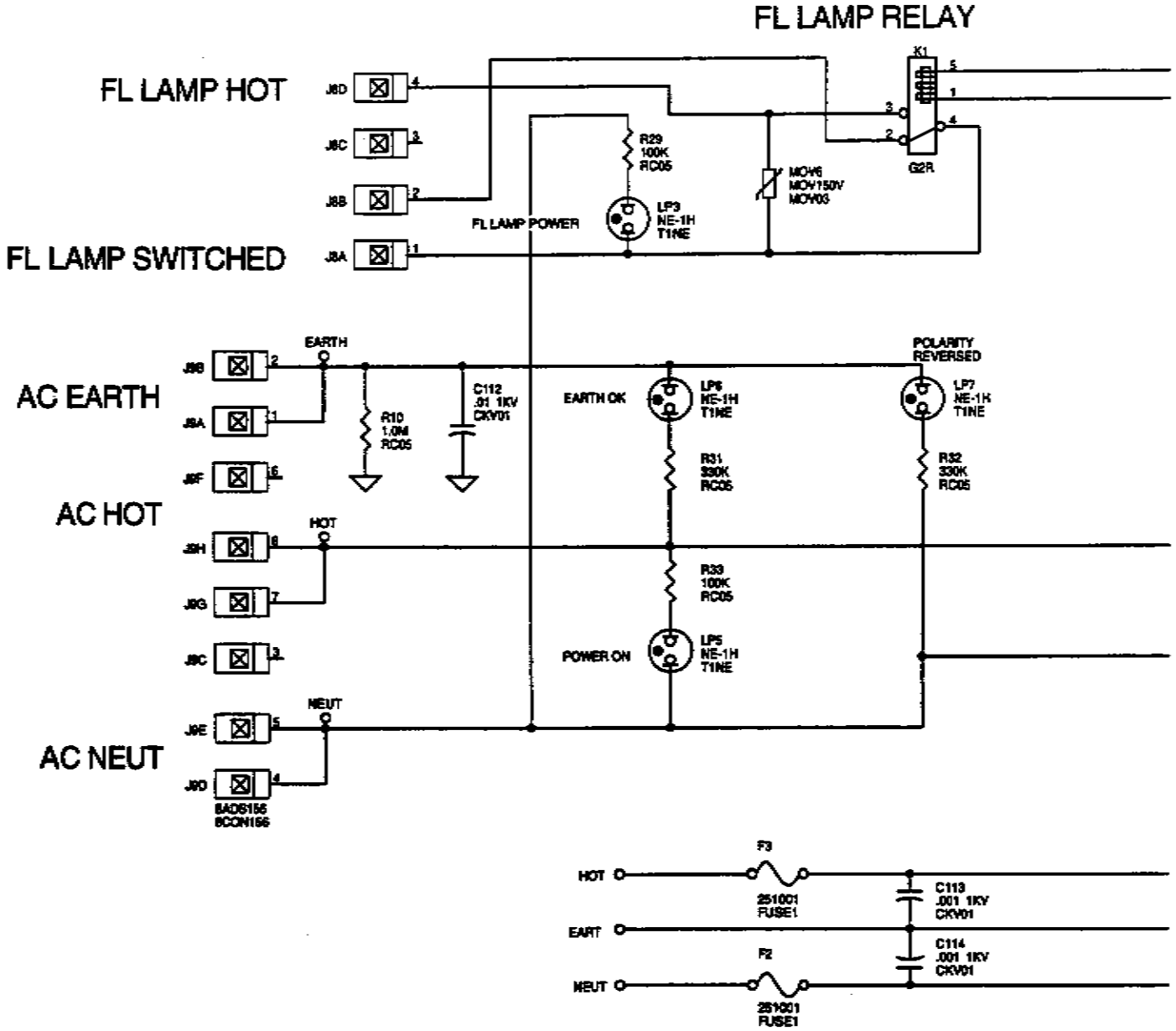

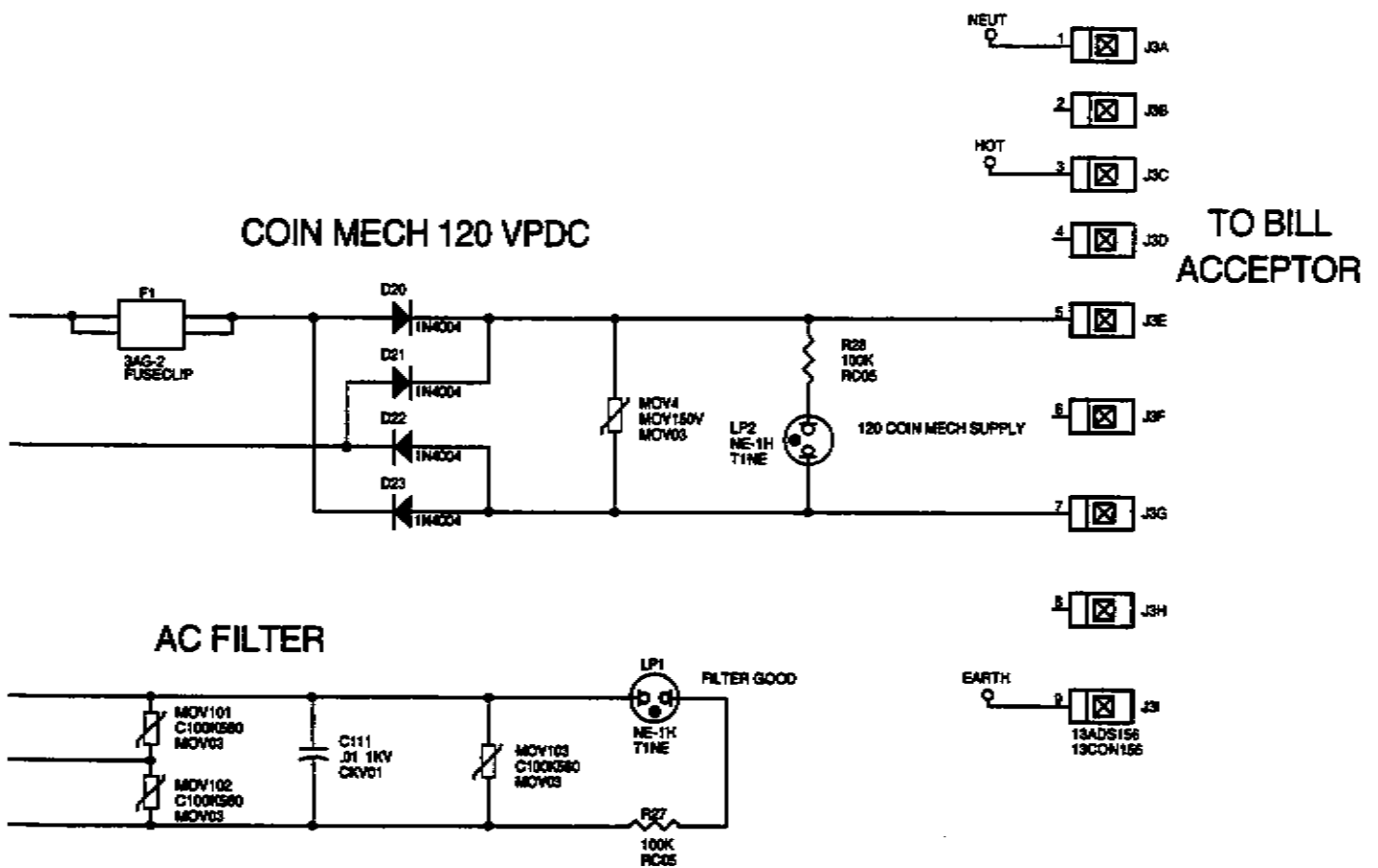
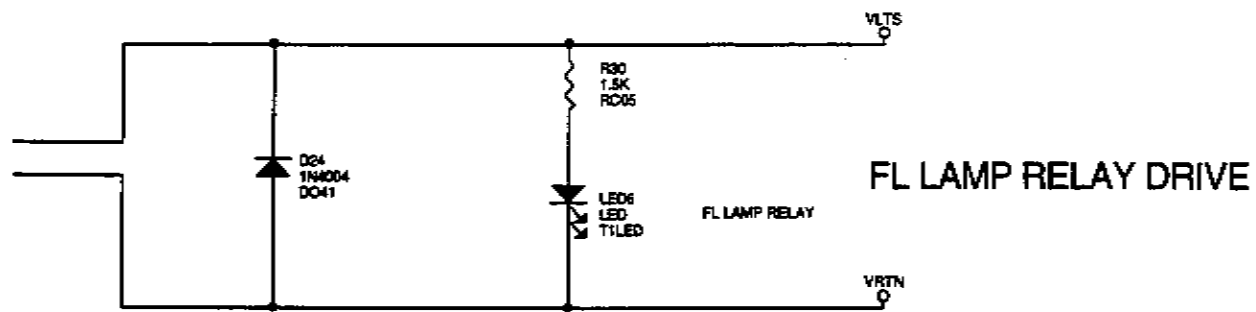

For Equivalent Engineering Drawing, See 28044700 B

Figure 4-8B. 548 Power Supply Schematic, Sheet 2

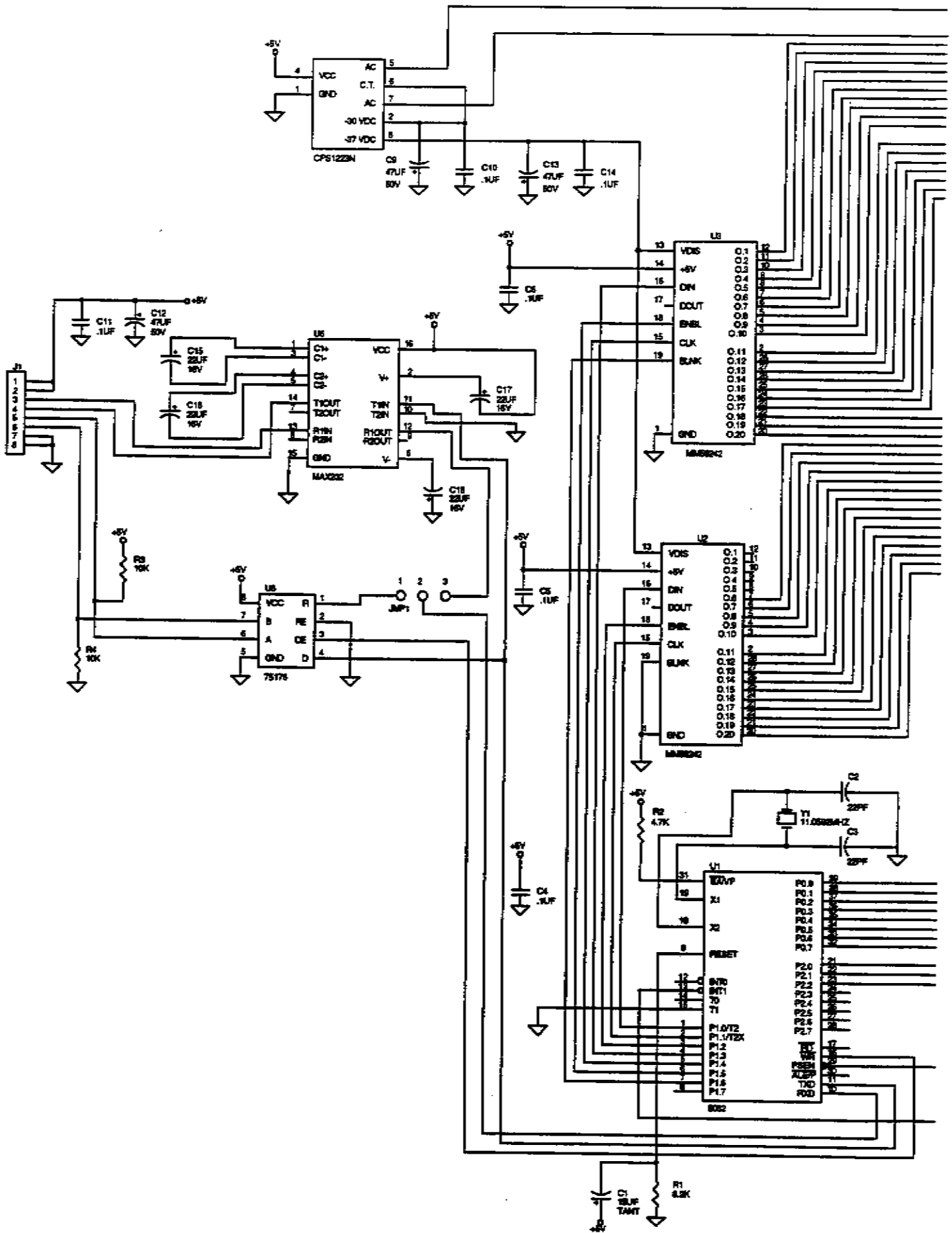

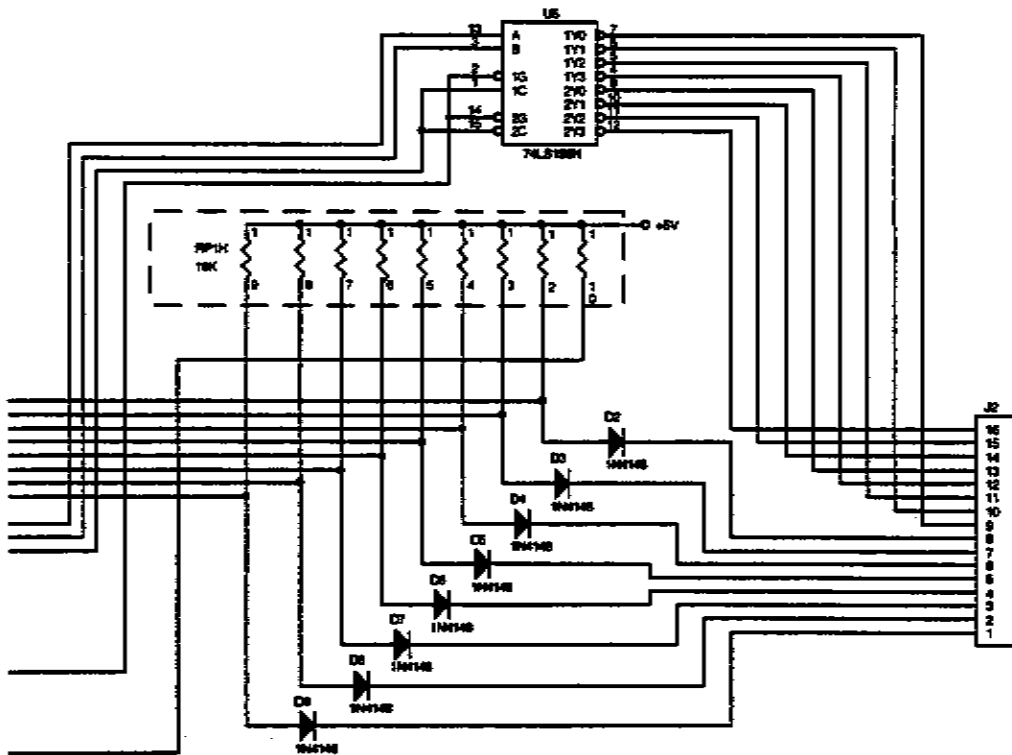
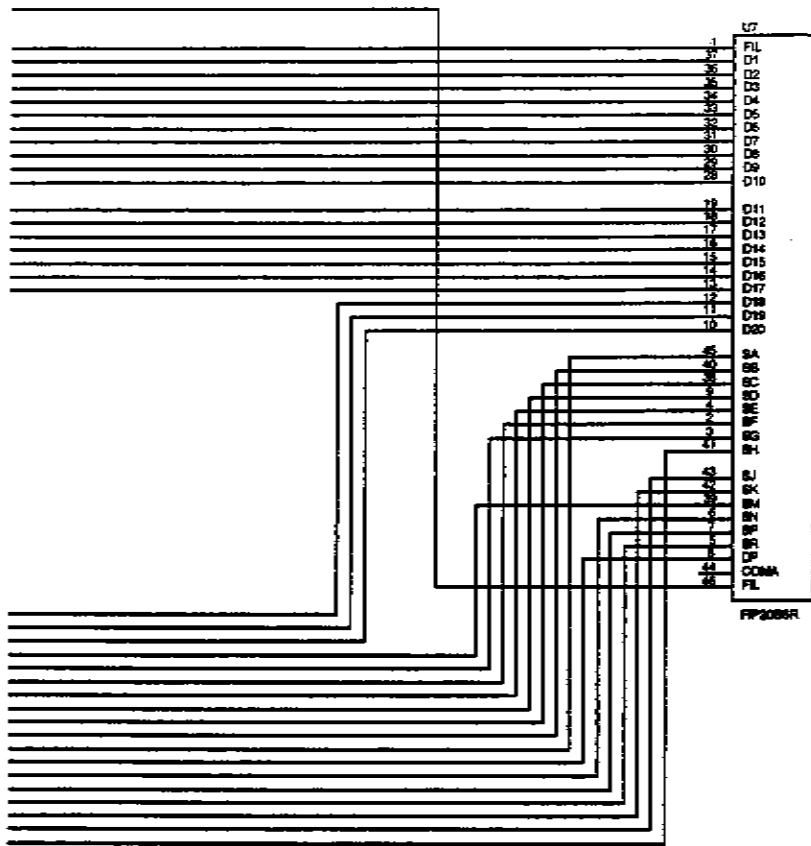

For Equivalent Engineering Drawing, See 28096900
Figure 4-9. Message Center Display Board

This page intentionally left blank.

Section 5

MAINTENANCE

INTRODUCTION

This section contains adjustment, repair and replacement procedures. All lubrication has been done at the factory and no further lubrication is required.

ADJUSTMENTS

The Showcase Merchandiser is adjusted at the factory for optimum performance and requires no additional adjustments unless parts have been repaired or replaced. Before attempting to make any adjustments to a mechanism, consult the troubleshooting charts to verify the need.

DELIVERY DOOR SWITCH

With delivery door closed, the switch should be open. When the delivery door is opened, the switch actuator should be making contact with the raised part of door follower and the switch should be closed. To adjust, loosen the switch mounting screws and rotate.

1. Turn the main power switch OFF.
2. Loosen both mounting screws and the unlatch solenoid assembly.
3. Hold the delivery door open 1-3/4" (use wood block).

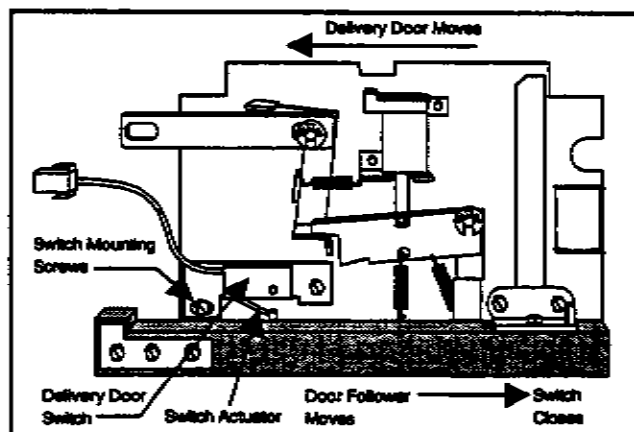

Figure 5-1. Delivery Door Switch

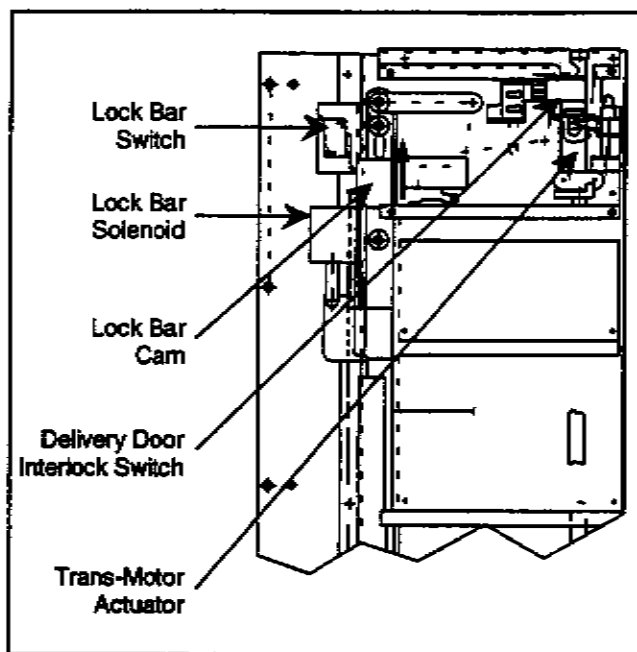

Figure 5-2. Lock Bar Switch
Delivery Door Interlock Switch

4. Place a .093" gauge under switch roller. Adjust the switch until the actuator "bottoms."
5. Remove the gauge and door block and check for switch roller operation. Make certain there is no binding.

LOCK BAR SWITCH

The switch should normally be making contact with the vertical edge of the "cam" and the switch should be "open." When the solenoid is energized, the switch actuator will fall off the beveled edge of the cam and the switch should be "closed."

Adjust as follows:

1. Turn the main power switch OFF.
2. Unlatch all delivery doors.
3. Connect the continuity light to the switch (common and normally closed).
4. Slowly close solenoid plunger. All latches must drop out before the light comes on.

- To adjust, loosen the two screws on the switch bracket assembly (or switch mounting screws if necessary).

TRANS-MOTOR INTERLOCK SWITCH

Adjust as follows:

- Remove the top cover over the Delivery Door Latch Assembly.
- Be certain all of the delivery doors are completely closed.
- Manually unlatch any delivery door.
- While observing the Interlock Switch Actuator, **SLOWLY** open the unlatched door.
- The Interlock Switch Actuator must not travel vertically more than 1/32" - 1/16" to actuate Interlock Switch. The interlock switch must be actuated before the door switch is actuated to prevent turret rotation while the vend door is open.
- Loosen the screw on the nylon switch actuator (P/N 448-813) and adjust accordingly. (Interlock Switch **MUST** be in the Normal Closed position when all delivery doors are closed)
- Recheck after adjusting.

Repair and Replacement

Most of the repair and replacement procedures for the Merchandiser are of an obvious nature. The following information is provided to aid service personnel in repairing or replacing parts that require additional information.

CAUTION !

This Refrigeration Unit Contains R404a under pressure. Refrigerant contact with skin should be avoided and protective eye-wear must be worn. Repairs should only be attempted by qualified mechanics trained and skilled in accepted Refrigeration techniques and procedures.

NEVER introduce other refrigerants into this system. Operating temperatures & pressures will be affected and the refrigeration unit will not operate correctly, possibly damaging the unit.

CHECKING THE REFRIGERATION SYSTEM

NOTE:

The entire Refrigeration Unit may be removed from the vendor and run on the bench to troubleshoot any given problem. Install a jumper wire capable of handling 10A (16 gauge) in the Cold Control Thermostat harness connector, and plug power cord into 120V grounded receptacle.

DO NOT allow unit to run for extended periods of time because the Evaporator may freeze without the cold control.

If the refrigeration system compressor is inoperative, perform the following checks before replacing the compressor. Be sure to hold the Refrigeration interlock switch closed when making the operational checks.

- Measure the line voltage. If the line voltage is below 105 volts, the compressor may fail to start.
- If line voltage is correct, check the automatic control thermostat operation by connecting a jumper wire across the terminal with the power disconnected.
- The Start Capacitor, Run Capacitor, and Start Relay are best tested by substituting them with known good components. This way there can be no doubt of test results.
- Check Thermal Overload for continuity.
- Check compressor motor windings with Volt/Ohm meter set on R + 1 scale. (Readings +/- 10%)

Common to Start	5 Ohms
Common to Run	1 Ohm
Start to Run	6 Ohms
- Check for grounded winding with Volt/Ohm meter from Start to metal casing and Run to metal casing. There should be no continuity. If there is, replace the compressor.

CAUTION !

To prevent injury or damage to the vendor, two people are required to perform the following procedure.

7. Check the high pressure cut-out switch. It is located on the compressor discharge line. Push the button to reset.
6. Unhook the delivery door return spring.
7. To replace, reverse the above procedure.

TURRET REMOVAL

1. Empty Turret of all product to prevent spillage.
2. Rotate Turret until the "zero" position magnet is facing straight forward and shut off the Main Line Switch.
3. Empty and remove the four storage racks.
4. Remove the single screw at the base of the dividing wall, slide it forward and remove.

NOTE:

A long handled 1/4" Spintite (12' or more) with a magnetized head, is recommended for step 5.

5. Remove two screws from upper pivot bearing. The bearing and pivot shaft will lay down on top of the turret.
6. Lift the turret assembly straight up high enough for turret base to clear the center bearing and drive helicopter and remove the turret.
7. Reverse this procedure to reinstall the turret.

CAUTION !

The white cover over the delivery door unlatch mechanisms being removed in step 2 of this procedure must be replaced correctly to ensure anti-cheat protection. The edges of the cover must be installed behind the lip on the delivery door runners.

DELIVERY DOOR REMOVAL

1. Remove the left hand fluorescent lamp and the white cover over the delivery door unlatch mechanisms.
2. Remove the four (4) screws from the bottom Runner of the door being replaced. (One screw on the right end of runner, 3 screws on left side of delivery door opening),
3. Remove the anti-spread bar.
4. Slide the bottom runner out to the left.
5. Lift the bottom of the door out first, then the top.

CLEANING

To project the best selling image to the customer, and to prolong the beauty and operation of the vendor, it is important to keep your Showcase Merchandiser clean.

Door Fan Filter

Check and wash out the door fan filter each month or as needed depending on location. If not cleaned for long periods, the efficiency and life expectancy of the fan motor and heating element will deteriorate.

Unit Exterior

Remove any debris lodged in the vend door runner tracks. Use a clean soft cloth moistened with a mild rated plastic cleaner to clean all vend doors and runner tracks. Metal and vinyl surfaces can be cleaned with warm water and a mild non-dulling detergent.

Unit Interior

Remove any debris that may have spilled or dripped into the compartments, interior lining and shelf areas. Use a clean lint-free cloth, moistened with a mild plastic rated cleaner.

Coin Mech

Check and clean regularly the coin paths leading through the flight deck and coin tubes. Use a lint-free cloth, moistened with a mild detergent.

Refrigeration System

The refrigeration intake screen should be checked routinely. It is easy to remove with the main door open.

The condenser coil and exhaust screen should be checked and cleaned at least once a year. These areas should be checked more often if the location is dusty or dirty.

The entire refrigeration unit needs to be pulled out to clean the condenser coil and exhaust screen. The process of removing the refrigeration unit is simple and easy and should only take about five minutes.

Follow the instructions on the next page.

Cleaning the Refrigeration Unit

1. Turn **OFF** the main power switch.
2. Remove the screws securing the right refrigeration cover, located at the lower front of the cabinet.
3. Unplug the 6 connectors on the power supply panel.
4. Remove the top center screw on the power supply panel and the screw to the right of the right most power supply hinge, then rotate the power supply forward.
5. Disconnect the refrigeration AC power plug to the refrigeration system, and three pin harness connector.
6. Disconnect the 6-pin connector to transport motor.
7. Disconnect the harness to the backup thermostat.
8. Slide the power supply to the right to remove it from the hinges. Set the power supply aside.
9. Remove the screws securing the front mounting bracket holding the refrigeration unit.
10. Unlatch the left & right side refrigeration unit levers
11. Slide the entire refrigeration system forward.
12. Clean out any debris in the air return housing.
13. Blow out and clean the condenser coil assembly.
14. Blow out and clean the cabinet rear exhaust screen.

NOTE:

Commercial products are available to clean the condenser. Follow the manufacturer's instructions.

Section 6

PARTS CATALOG

Parts Catalog Contents

Fig. No.	Description	Pg. No.
1	Main Door and Trim Panels	6-4
2	Main Door (Exterior)	6-6
3	Message Center	6-8
4	Main Door (Interior)	6-10
5	Lower Main Door Components	6-12
6	Coin Mech Compartment	6-14
7	Door Assembly - Coin Mech Compartment	6-16
8	Delivery Door Panel Assembly	6-18
9	Cabinet Final Assembly	6-20
10	Power Supply Assembly	6-24
11	Main Panel Switch	6-26
12	Turret Drive Motor Assembly	6-28
13	Turret Components - Bottom	6-30
14	Turret Drive and Roller	6-31
15	Lock Bar Solenoid	6-32
16	Refrigeration Unit	6-33
17	Universal Control Board	6-35
18	Power Supply Circuit Board Assembly	6-38
19	Harness List	6-41
20	European Part Numbers	6-42
22	Hardware List	6-43
	Index	6-45

Optional Kits

Part No.	Description	Function
448-66019	Universal Bill Acceptor	Allows Currency Acceptance
548-06000	Printer Harness Kit	Allows MIS retrieval via printer
548-06003	MARS VFM3 Adapter Kit	MARS B/A Useage
548-06013	Third Light Kit	Install Center Light

Parts Catalog

INTRODUCTION

This parts catalog contains a list of replacement parts for the vendor that are available. Each list contains an index of the part, the part number, a description of the part and the quantity required for the assembly. Separate parts of riveted or welded assemblies are not available from the factory as replacement parts.

Parts Callout

Each table in the Parts Callout contains four columns. Following is a description of each column in the order of appearance on the Parts Callout tables.

Fig. and Index No.

This column lists the figure number as the first entry on each page. An index number keys the part to the figure.

Part No.

This column lists the part number of the item that should be used for ordering. The same part, whenever used, retains the same number.

Description

This column gives the name of the assembly or part.

Quantity per Assembly

This column contains the exact quantity of the item required for its next higher assembly.

ORDERING REPLACEMENT PARTS

All parts must be ordered from an authorized part supplier. Parts orders are often delayed because of inadequate or incomplete ordering information. Be sure to include all required information which consists of:

1. The part number and description exactly as it appears in the Parts Catalog. State color if applicable.
2. Quantity being ordered.
3. Model and Serial Number of vendor for which the part is required. This is necessary because of Manufacturing changes.
4. Complete shipping address including ZIP code.
5. Specify shipping instructions. It is advisable to indicate an alternate shipping method if the packages may exceed the size and weight limits established by the shipping agency of your choice.

Main Door and Trim Panels

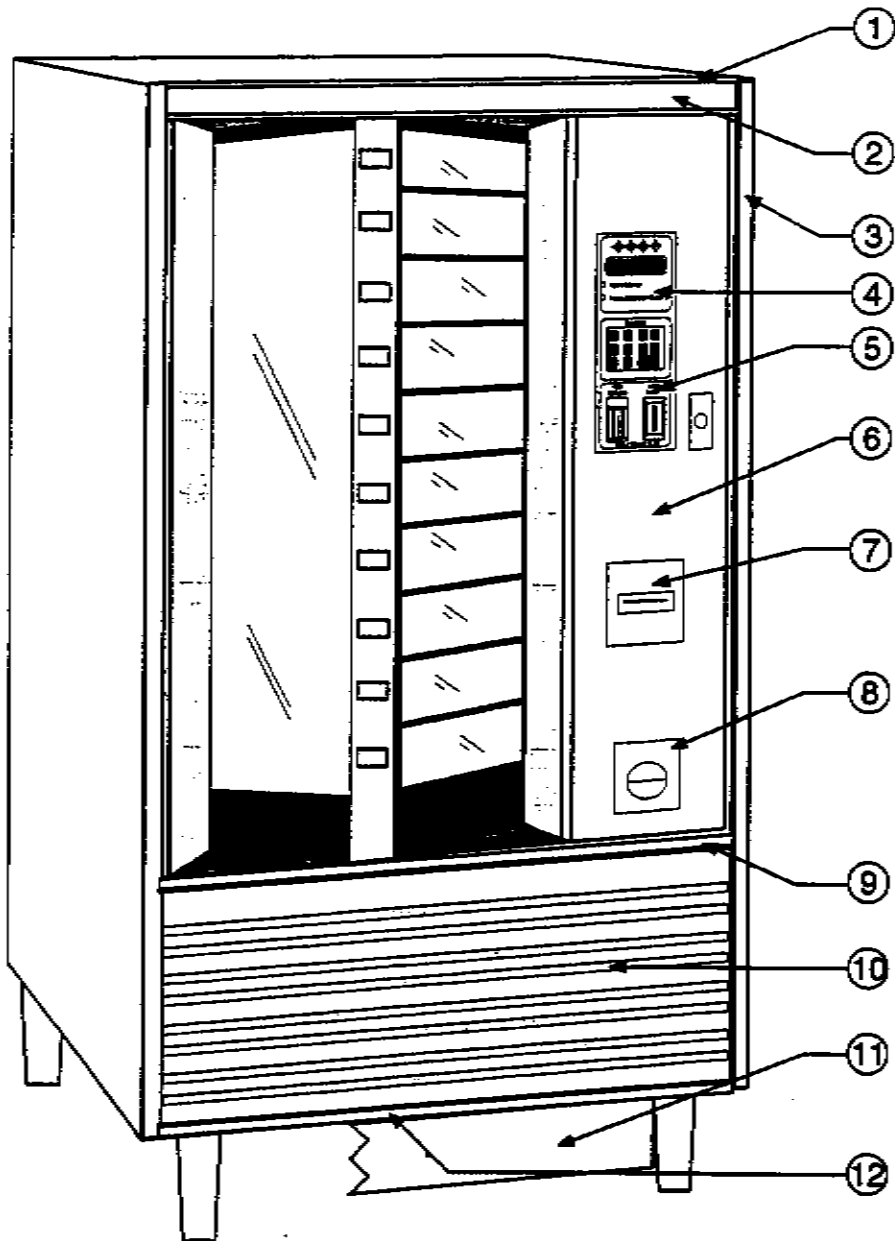

Main Door and Trim Panels

Number	Description	Genesis	Award	Stellar	Imperial Crown
1	Channel - Header	983-3	983-3	983-4	983-3
2	Insert - Header	985-3-9	985-3-1	448-1477	985-3-2
3	Trim - Sides Vertical	983-101	983-101	983-100	983-101
	Trim Retainer - Vertical	983-325	983-325	983-325	983-325
4	Overlay	548-451	548-451	548-450	548-451
5	Overlay	548-421	548-421	548-420	548-421
6	Panel w/UBA	448-2531-9	448-2531-7	448-2531-79	448-2531-12
	Panel w/o UBA	448-30501-9	448-30501-7	448-30501-79	448-30501-12
7	Overlay w/UBA	448-2527	448-2527	448-2526	448-2527
	Overlay w/o UBA	448-2533	448-2533	448-2534	448-2533
8	Overlay	907-1088	907-1088	907-1088	907-1088
9	Trim - Horizontal	983-224	983-206	983-207	983-206
	Trim Retainer - Horizontal	983-329	983-329	983-329	983-329
10	Panel	448-12472	985-22-1	448-1478	985-22-2
11	Kickplate (OPT) (Black)	448-6028	448-6028	448-6028	448-6028
12	Trim - Horizontal - Bottom	448-743-239	448-743-246	448-743-246	448-743-246

Panel Styling Suffix Numbers

There are many combinations of panel and overlay finishes based on styling or individual company preferences. Part numbers for the styling overlays and panels are generally the same with the exception of last dash number which denotes the finish of the part.

NOTE:

Start with the basic part number obtained from Fig. 1 (Page 6-4) and substitute the last dash number for the "finish" desired.

HORIZONTAL PANELS

- 1 Rosewood
- 2 Presidential Walnut
- 3 Regency Walnut
- 4 Kashmir Walnut
- 9 Black
- 10 Golden Leather
- 79 Charcoal Brown

VERTICAL PANELS

- 5 Stainless Steel Mylar
- 29 Teak
- 32 Terra Cotta
- 69 Chamois
- 78 Sterling Royse
- 29 Teak
- 2 Presidential Walnut
- 7 Shadow Silver
- 11 Brushed Bronze
- 12 Port Au-Prince
- 15 Stainless Steel Mylar
- 78 Sterling Royse

Main Door (Exterior)

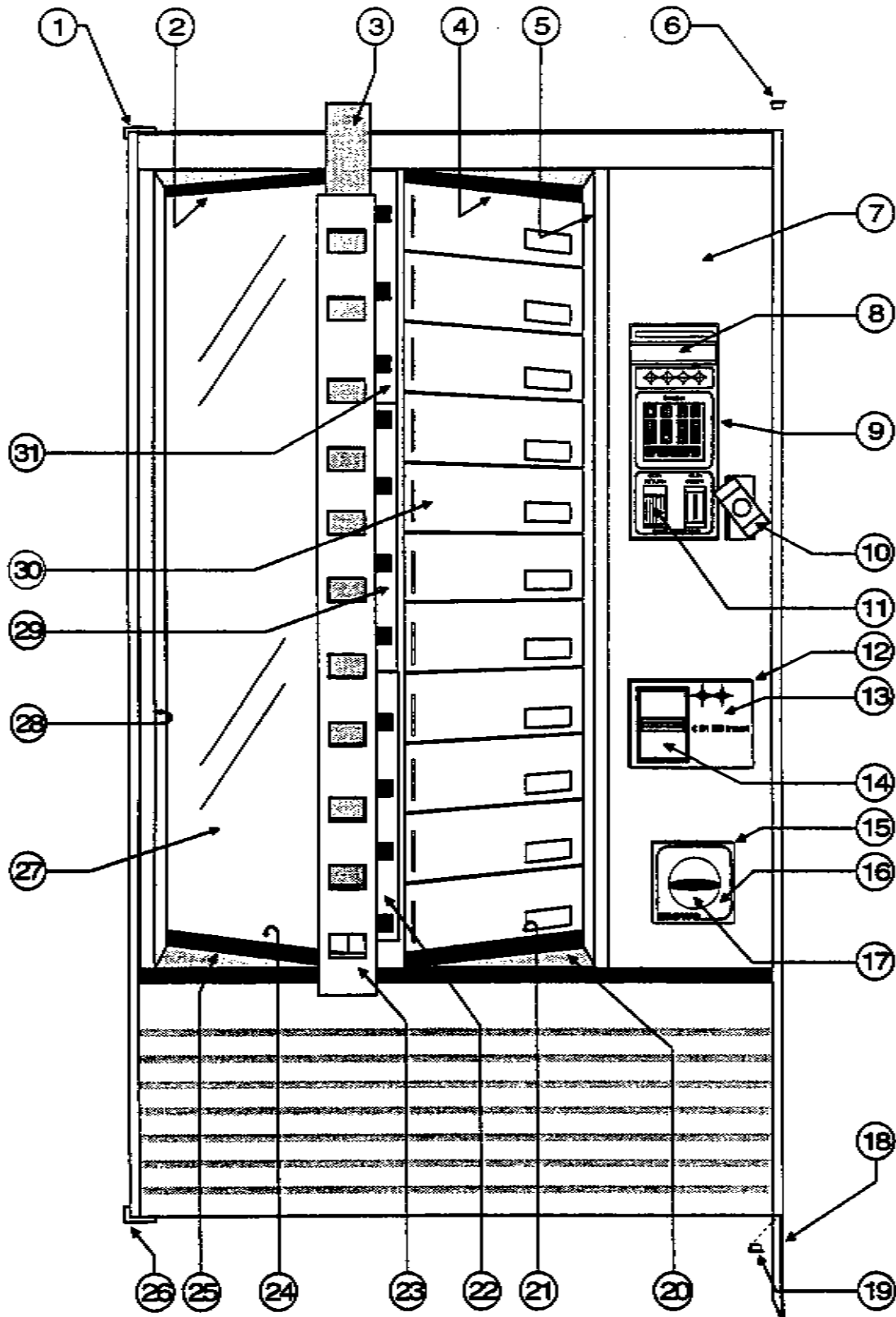

Index No.	Part Number	Description	Quantity Per Assembly
	548-01400	Main Door Final Assembly	REF
	548-01401	Main Door Weld Assembly	1
1	448-01309	Pivot Plate Rivet Assembly Top (Also in Fig 9)	1
	921-00496	Screw, Counter Sunk - Phillips (Not Shown)	3
2	548-00411	Extrusion - Glass - Top	1
3	548-00416	Lens - Display	1
4	548-00463	Extrusion - Runner Retainer - Top	1
5	548-00468	Panel, Air Duct	1
	548-00470	Seal, Air Duct (Not Shown)	
6	408-00511	Cap, Trim Top	1
7	548-01402	Coin Mech. Compartment Door Assembly (No Overlay) - See Fig 6	1
8	500-01010	Message Center/Coin Insert (See Fig. 3)	REF
9	548-00449	Bezel, Coin Insert	1
	548-20500	Bezel- Coin Insert - Univ. Cntrl. (European)	REF
	924-00176	Nut, Bezel Mounting (Not Shown)	6
10	479-01420	Pop-Out Handle Assembly (See Fig. 6)	1
	903-00016	Carriage Bolt, Handle Mounting	2
	924-00037	Nut, Handle Mounting	2
11	490-00470	Slide, Coin Return	1
12	448-02525	Bezel, U.B.A.	1
	934-00383	Screw, Bezel Mounting	4
	448-02555	Filler Plate (if U.B.A. is removed)	ALT.
	934-00428	Screw, Filler Plate Mounting	2
13	448-02527	See Door Style Page 6 - 4	REF
14	448-66019	Universal Bill Acceptor	OPT.
15	490-00408	Bezel, Coin Return Cup	1
	924-00176	Nut, Bezel Mounting	4
16	907-01088	C/R Bezel Overlay (See Door Style Page 6 - 4)	REF
17	448-21510	Cup, Coin Return W/A (See Fig 6)	REF
18	448-00575	Leg, Door Stabilizing	1
19	408-00510	Cap, Trim Bottom	1
20	548-00423	Sill, Bottom Right Side	1
21	548-00464	Extrusion, Runner Retainer - Bottom	1
22	548-01806	Price Display Assembly - Bottom	1
23	548-00414	Extrusion - Price Display	1
24	548-00410	Extrusion, Glass Bottom	1
25	548-00422	Sill, Bottom Left Side	1
26	448-01407	Pivot Plate, Rivet Assembly - Bottom (See Fig. 9)	1
	921-00496	Screw, Counter Sunk - Phillips (Not Shown)	4
27	548-01800	Heated Glass and Gasket Assembly (See Fig. 4)	1
28	548-00472	Trim, Door - Left Side	1
29	548-01805	Price Display Assembly - Center	1
30	448-01428	Delivery Door - 5"	2
	448-01427	Delivery Door - 4"	9
31	548-01804	Price Display Assembly - Top	1
32	548-00437	Locator PC Board	1

Message Center

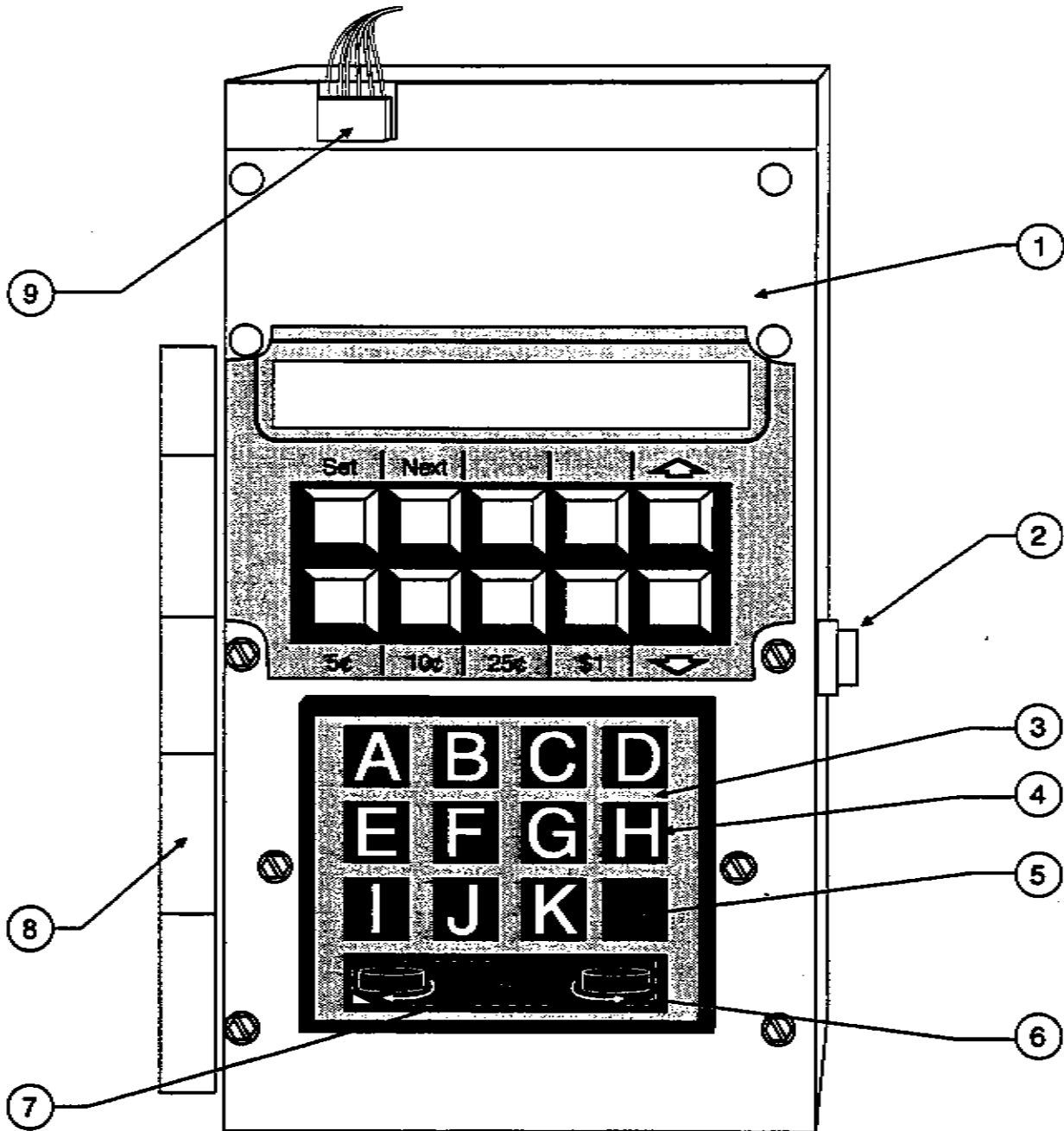

Index No.	Part Number	Description	Quantity Per Assembly
	500-01018	Message Center Complete (Contains everthing listed below)	REF
1	500-01010	Message Center Assembly (Contains ONLY parts indented below)	1
	500-00100	Overlay - Message Center	1
	500-00101	Housing - Keyboard	1
	500-01011	Keyboard Assembly & PCB	1
	28096701	Display Board	1
	934-00307	Screw	5
	500-01017	Harness (Not Shown)	1
	500-00117	Cover, Message Center	1
	914-00007	Push Fastener	4
2	548-00434	Keeper - Message Center Latch	1
	934-00428	Screw, Keeper Mounting (Not Shown)	1
3	548-00800	Grid - Button Keypad	1
4	010-30873-226	Pushbutton Set ("A" Thru "K")	1
5	010-30838-111	Pushbutton ("BLANK")	1
6	548-00801	Pushbutton, Rocker	1
7	907-02191	Label (Decal) Carousel Rotator	1
8	548-00432	Hinge, Message Center	1
9	548-01819	Harness - UCB P2 to Message Center	1

Main Door (Interior)

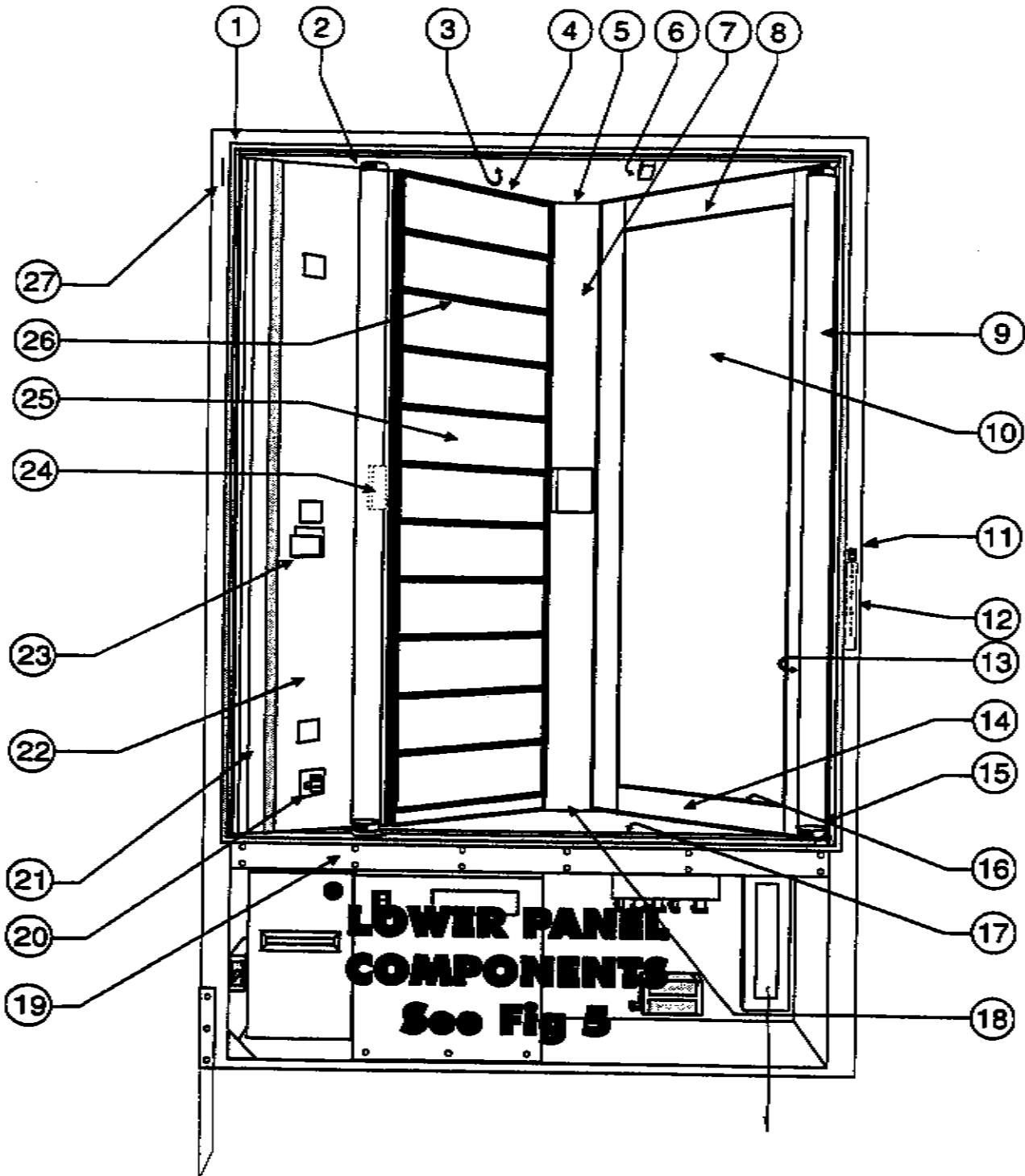

Index No.	Part Number	Description	Quantity Per Assembly
	548-01400	Main Door Final Assembly	REF
	548-01401	Main Door Weld Assembly	1
1	928-03500	Gasket, Main Door Sealing	1
	934-00448	Screw	44
2	548-01840	Socket Assembly - Fluorescent Lamp - Top and Bottom	2
	448-00549	Socket - Fluorescent Lamp	2
3	548-00438	Liner, Door - Top	1
4	448-14020	Rail & Cover	12
	448-00491	Molding - Door Runner	1
	448-00693	Runner, Delivery Door - Top and Bottom Only	2
5	448-02507	Bracket, Centerpost - Upper (If so Equipped)	1
6	548-00452	Housing, Zero Position Switch	1
	548-00453	Pad, Zero Position Switch Retaining	1
	548-01816	Switch Assembly, Zero Position	1
7	548-01419	Cover - W/A Insulation	1
	548-00517	Insulation - Price Display (Under Cover)	1
	548-00478	Retainer - Glass, Center (Under Insulation)	1
8	548-00413	Retainer, Glass - Top	1
	934-00448	Screw - Retaining Mounting	3
9	917-00114	Lamp - Fluorescent	2
	917-00200	Safety Shield	2
10	548-01800	Glass and Gasket, Heated	1
11	707-03904	Service Switch	1
12	907-02218	Label - "Service Switch"	1
13	548-00824	Cover, Lamp / Harness Panel	1
	548-01413	Retainer - Glass, Right (Under Cover)	1
14	548-00412	Retainer, Glass - Bottom	1
15	448-02804	Bracket, Socket Mounting - Bottom	1
16	548-01849	Wire, Heater (Heater Strip Not Shown)	1
17	548-00439	Liner, Door - Bottom	1
18	448-02506	Bracket, Centerpost - Bottom (If so Equipped)	1
19	448-02514	Cover, Door Channel	1
20	548-01818	Probe, Temperature Sensing	1
	548-00441	Cover, Temperature Sensor	1
	934-00307	Screw, Cover Mounting	1
	975-00602	Clip - Type 5, Nylon	1
	548-00506	Insulator Plate - Temperature Sensor	1
21	448-00555	Cover, Harness	1
22	448-12471	Cover and Guard Weld Assembly	1
23	448-00597	Holder, Price Cards	1
	934-00077	Screw	1
24	548-04005	Bracket (Left)	1
25	548-01410	Delivery Door Mech Assembly - 4"	9
	548-01411	Delivery Door Mech Assembly - 5"	2
26	448-14020	Rail and Cover	10
	448-14015	Extension Runner (Not Shown)	12
	448-00492	Stop, Delivery Door (Not Shown)	A/R
	448-00723	Spacer, Large Compartment (Not Shown)	A/R
27	448-00586	Guard, Gasket - Main Door	1
*	448-01917	Selection Card Assortment - "A" thru "K" (Not Shown)	1

Lower Main Door Components

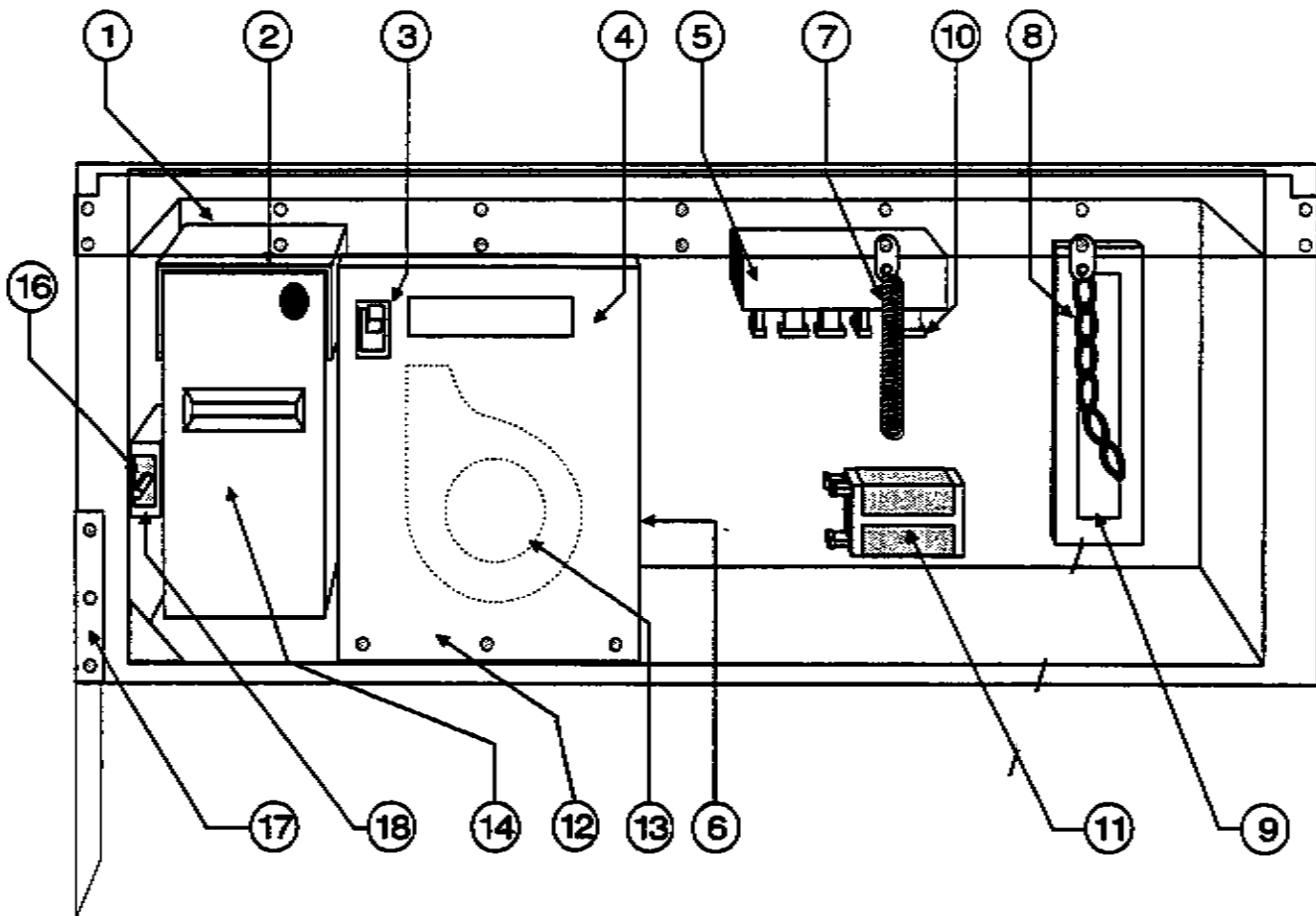

Index No.	Part Number	Description	Quantity Per Assembly
1	448-02514	Cover, Door Channel	1
	934-00492	Screw	14
2	448-12403	Cash Box Mounting Bracket W/A	1
	934-00357	Screw	4
3	548-01847	Switch, Heater / Fan Unit	1
4	934-00357	Label - Heater Blower	1
5	548-00827	Cover - Blower Enclosure	1
	934-00151	Screw	6
6	448-00856	Filter	1
7	212-00328	Spring - Extension	1
	975-00552	Tie - Type-16, Nylon	2
	934-00307	Screw	2
8	448-00935	Chain - Door Restraint	1
9	548-01867	Ballast - 2 Lamp 40 Watt, 60 Hz.	1
	448-12871	Ballast - 2 Lamp 40 Watt, 50/60 Hz. (European)	1
	934-00457	Screw	2
10	548-01845	Filter Assembly	1
	934-00307	Screw	2
11	448-01532	Transformer - 115V	1
	548-21534	Transformer & Bracket Assembly - 220V	1
	934-00324	Screw	2
12	548-01873	Enclosure W/A - Blower	1
13	548-01846	Blower & Heater Outlet Assembly	1
	448-04622	Heater Assembly	1
	448-01886	Blower Assembly	1
	448-04544	Blower Motor Only	1
14	448-01916	Cash Box W/A	1
15	526-02186	Switch - Door Interlock	1
16	448-00575	Leg - Door	1
	934-00307	Screw	3
17	448-02496	Bracket - Interlock Switch Mounting	1
	934-00307	Screw	2

Coin Mech Compartment

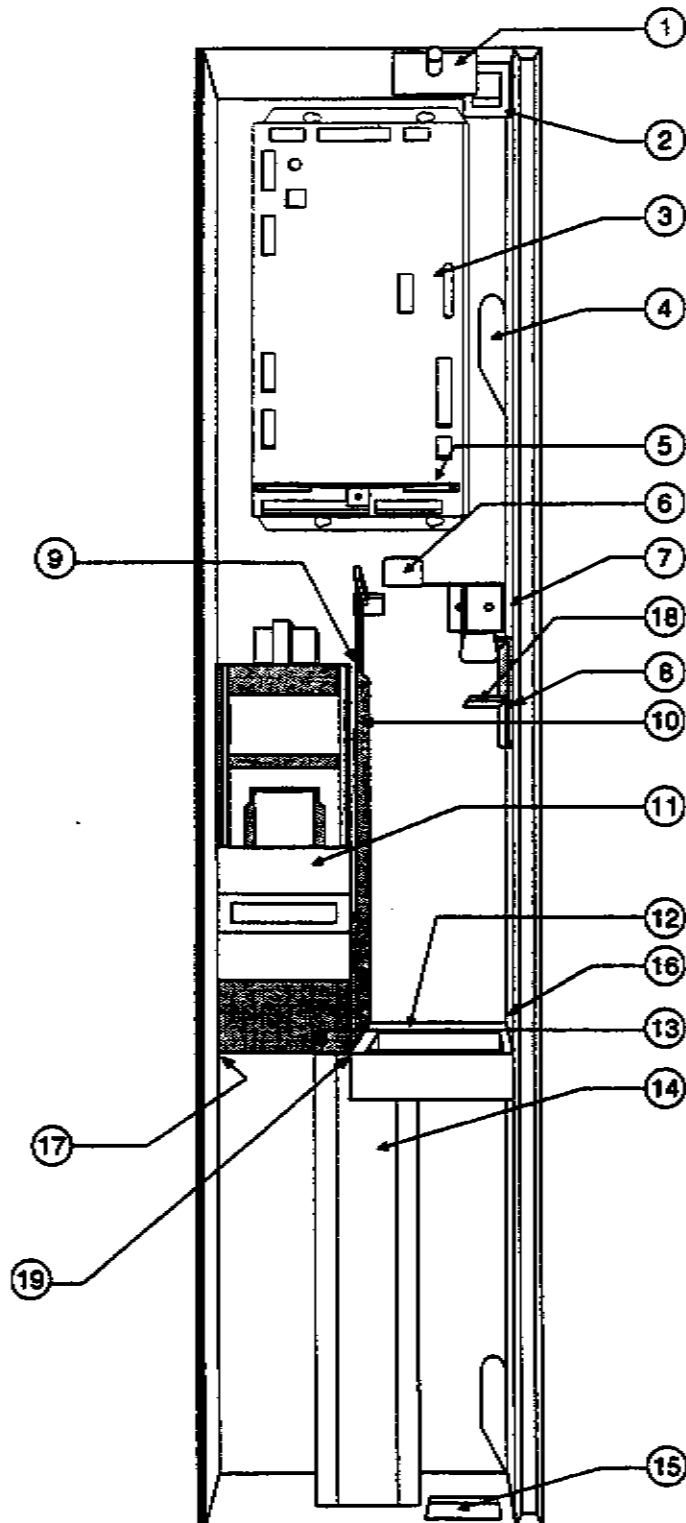

Index No.	Part Number	Description	Quantity Per Assembly
1	448-01591	Switch, Coin Mech Door Interlock	1
	548-00810	Bracket, Switch Mounting	1
2	448-00487	Bracket, Locking - Top	1
	934-00307	Screw	2
3	500-01000-6	Universal Control Board Assembly - See Fig. 17	1
4	448-01417	Latch Assembly, Main Door	1
	934-00307	Screw	8
5	548-01407	Stop Assembly, Message Center	1
	934-00151	Screw	2
6	448-12416	Lever and Actuator Assembly, to Coin Return	1
	448-02457	Lever, Actuator Assembly to Coin Mech Door	1
	448-02459	Bracket, Lever Mounting	1
	448-02458	Lever, Coin Mech Roller Actuator	1
	133-00481	Spring, Lever Return	1
	448-02480	Step Washer, Lever Pivot	1
	934-00307	Screw, Lever Pivot	1
	448-02563	Bracket, Coin Mech Position	1
7	448-02560	Link - Nest Stop (Not Shown)	2
	448-02562	Pivot - Link (Not Shown)	2
	448-00418	Hook - Locking	1
8	448-2560	Link - Nest Stop	1
	448-2562	Pivot - Link	1
10	448-12468	Nest, Coin Mech and UBA Mounting	1
	448-12469	Nest, Rivet and Weld Assembly	1
	448-02481	Pivot, Actuator	2
	448-02556	Plate, Swivel - Coin Mech Mounting	1
	448-02561	Slide Latch - Nest Assembly	1
	950-00045	Washer	1
	132-00069	Spring, Latch	1
11	448-66019	Universal Bill Acceptor	OPT
12	448-12402	Coin Chute W/A - (To Coin Return Cup)	1
13	448-02559	Pivot Shaft - Coin Mech Nest	1
	448-02472	Keeper, Pivot Shaft	1
14	448-12470	Coin Chute W/A - (To Cash Box)	1
15	448-00485	Bracket, Locking - Bottom	1
16	448-02472	Keeper - Coin Mech	1
17	448-02469	Bracket - Pivot CBA	1
18	548-01406	Mounting Plate R/A - Coin Mech Socket	1
	548-00435	Bracket - Mounting, Coin Mech Socket	1
	548-01825	Harness - UCB to Coin Mech Socket	1
	909-00022	Pin - Drive, .073 x 1"	1
	975-00549	Tie Type 16 - Nylon	1
	924-00177	Nut	1
	548-00499	Retainer, Coin Mech Plug (Large)	1
	448-02477	Retainer, Coin Mech Plug (Small)	1
	408-00431	Knob, Torque (Not Shown)	1
	--	548-01884	Harness (Solenoid Protection) (UCB P-16) (Not Shown)

Door Assembly, Coin Mech Compartment

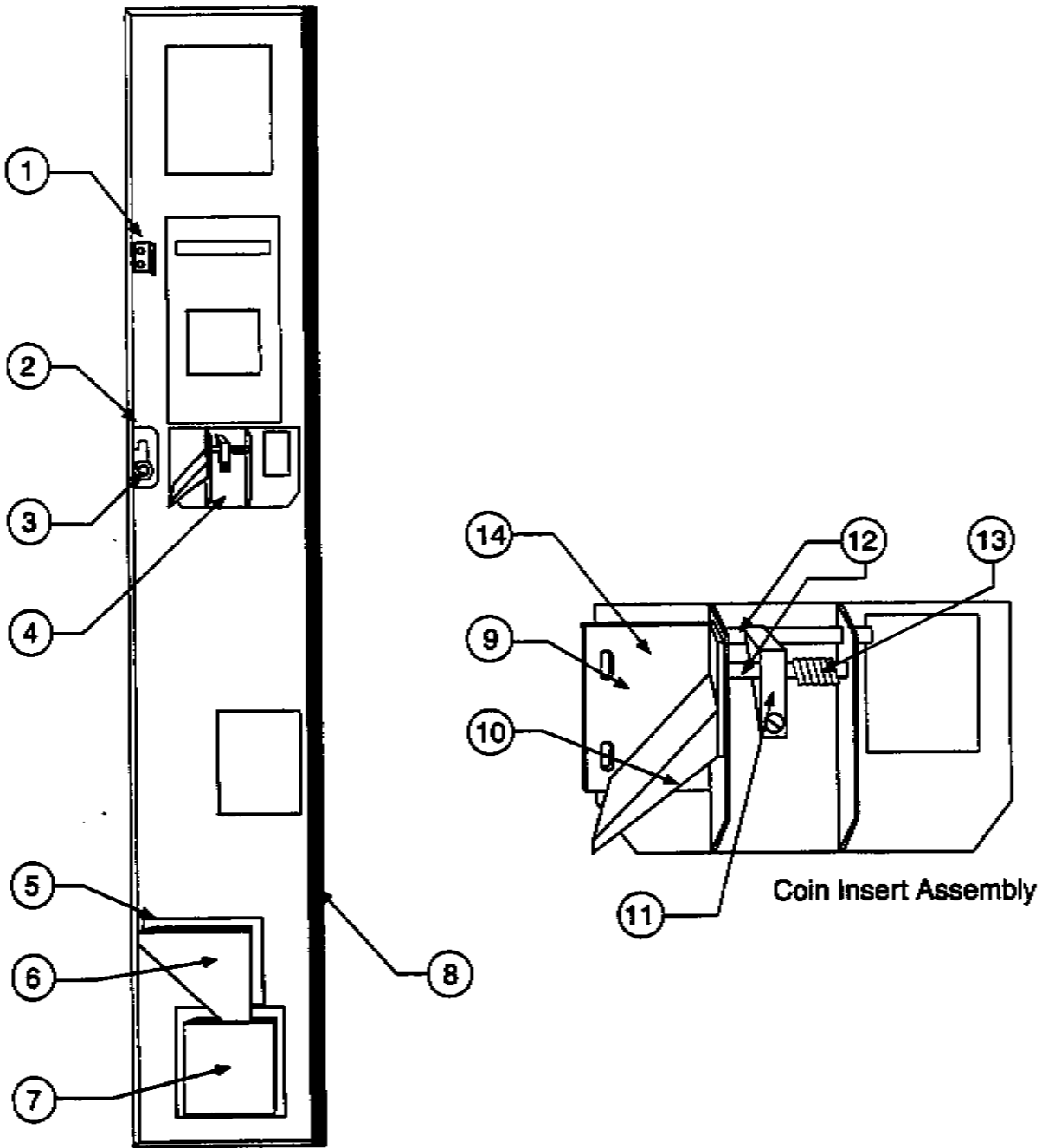

Index No.	Part Number	Description	Quantity Per Assembly
	548-4508	Coin Mech Compartment Door - Complete w/ Award Styling (Euro.)	REF
	548-4509	Coin Mech Compartment Door - Complete w/ Imp. Crown Styling (Dom.)	REF
	548-4510	Coin Mech Compartment Door - Complete w/ Genesis Styling (Dom.)	REF
	548-4511	Coin Mech Compartment Door - Complete w/ Award Styling (Dom.)	REF
	548-4512	Coin Mech Compartment Door - Complete w/ Award Styling (Euro.)	REF
1	548-00433	Latch Spring, Message Center	1
	924-00054	Nut 2	
2	448-00733	Bracket, Coin Mech Door Lock Bar	1
	934-00151	Screw	2
	448-02417	Lock Bar, Coin Mech Door	1
	933-00004	Retaining Ring	2
3	448-01549	Cam, Lock Bar Actuator	1
	448-00734	Spacer, "T" Handle Nut	1
	924-00181	Nut, "T" Handle	1
	548-01402	Door Assembly, Coin Mech Compartment	REF
	548-01404	Door R/A, Coin Mech Compartment	1
4	548-01422	Coin Insert Assembly	1
5	448-02426	Chute, Coin Return	1
6	448-02427	Back Chute, Coin Return	1
7	448-21510	Cup, Coin Return	1
	490-00409	Flap, Coin Return Cup	1
	490-00424	Pivot Shaft, Coin Return Flap	1
	941-00008	Speed Nut, Pivot Shaft	1
	934-00320	Screw, Coin Return Cup Mounting	5
	924-00054	Nut, Chute Mounting	2
8	448-02565	Hinge, Coin Mech Compartment Door	1
9	548-01414	Bracket W/A - Coin Insert	1
	934-00324	Screw, Bracket Mounting	4
10	448-02424	Coin Chute	1
	448-02425	Backing Plate, Coin Chute (Gate)	1
	934-00151	Screw	5
11	448-12408	Lever & Nut, Coin Return	1
	921-00026	Screw, Coin Return Lever	1
	924-00006	Nut, Coin Return Lever	1
12	490-00435	Pivot Shaft, Coin Return	2
	933-00005	Retaining Ring	3
13	490-00498	Spring, Lever Return	1

Index No.	Part Number	Description	Quantity Per Assembly
	548-01403	Delivery Door Panel Assembly	REF
1	548-01410	Delivery Door Latch Assembly - Complete - 4"	9
	448-01434	Latch Plate Rivet Assembly - 4"	9
	548-01411	Delivery Door Latch Assembly - Complete - 5"	2
	448-01435	Latch Plate Rivet Assembly - 5"	2
2	548-01857	Solenoid and Diode Assembly - Unlatch	11
3	448-00510	Interlock Slide 4"	8
	448-00511	Interlock Slide 5"	2
4	448-01403-003	Spool and Spring Assembly	11
	448-00443	Drum, Delivery Door Spring	11
	448-00513	Spring, Delivery Door Return	11
5	448-00509	Guide, Locking Slide	11
6	448-00495	Pawl, Latch Mechanism	11
7	448-00508	Stop, Pawl	11
8	933-00004	"E" Ring	33
9	21256201	Spring, Lockout and Tension (Silver)	22
10	448-01411	Switch Actuator Link - (Not Visible)	11
11	448-00492	Stop, Delivery Door	9
	448-00723	Spacer - Large Compartment (Not Shown)	2
12	490-00908	Bumper, Delivery Door (Not Visible)	12
13	548-01841	Switch Assembly, Delivery Door (Includes Mounting Bracket)	9
14	448-12806	Latch Link R/A - (Includes Solenoid Plunger)	11
15	448-00432	Latch	11
16	448-00434	Link, Reset	11
17	448-00514	Spring, Delivery Door Latch	11
18	548-01408	"Z" Bracket and Switch Assembly (Includes Switch)	1
	448-01409	"Z" Bracket and Pin	1
	548-01817	Switch Door Interlock	1
	448-00460	"Z" Runner Mounting	1
19	548-01817	Switch, Motor Interlock (Switch Only)	1
	548-00454	Bell Crank - Switch Actuating	1
20	548-00474	Retainer, Actuator Return Spring	1
21	333-00454	Spring, Actuator Return	1
22	548-00458	Interlock Slide - Top Door Assembly - ONLY	1
23	448-00813	Actuator - Top and Bottom	2
	921-00037	Screw	2

Cabinet Final Assembly

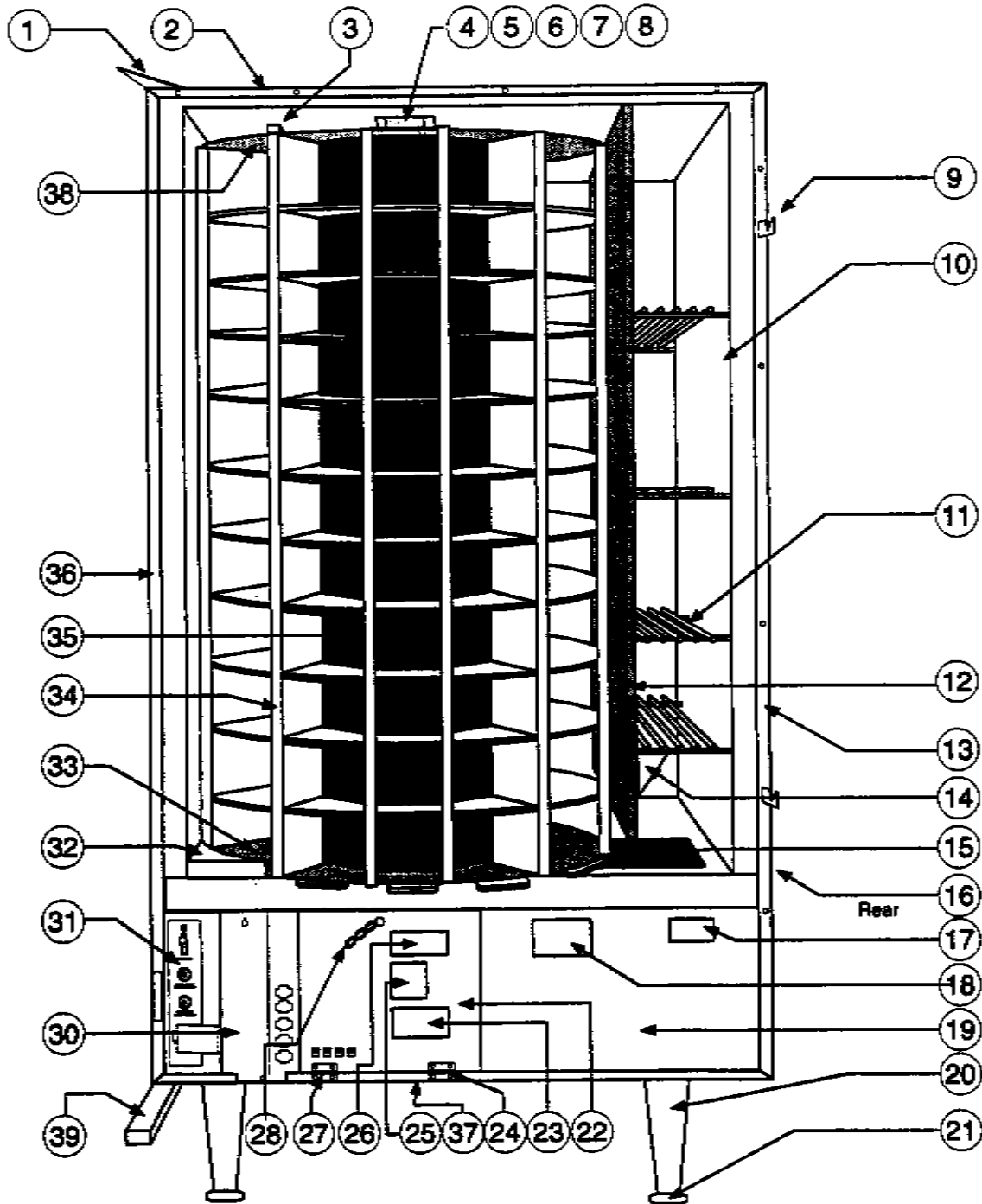

Index No.	Part Number	Description	Quantity Per Assembly
	548-01300	Cabinet Final Assembly	REF
	548-01305	Cabinet Weld Assembly	1
1	448-01309	Top Pivot Plate - Also in Fig. 2	1
	934-00291	Bolt (Not Shown)	2
	903-00005	Carriage Bolt (Not Shown)	1
	924-00160	Nut (Carriage Bolt) (Not Shown)	1
2	548-00461	Retainer, Liner Top	1
3	448-12883	Magnet and Bracket Assembly	1
	929-00154	Rivet	2
4	448-02009	Hat, Bearing Bracket (See Detail 9.1)	1
	916-00208	Grommet - Insulator, Type 12	4
	448-02916	Insulation - Pivot Mounting Bracket	1
	448-12108	Bearing Bracket	1
5	448-02010	Bearing, Pivot Shaft (See Detail 9.1)	1
6	448-02012	Shaft, Upper Pivot (See Detail 9.1)	1
7	448-02013	Bracket, Pivot Shaft Mounting (See Detail 9.1)	1
	934-00307	Screw	4
8	448-02014	Pin Clevis	1
	905-00051	Hair Pin (Clevis Pin Retaining)	1
9	448-02349	Hook, Main Door Latching	2
	934-00199	Screw, Hook Mounting	6
10	448-02333	Liner, Cabinet	1
11	448-12901	Shelf, Storage	4
12	548-01901	Divider, Shelf and Reinforcement W/A	1
13	548-00460	Retainer, Liner R/H Side	1
14	448-44004	Bracket, Shelf Mounting	2
15	448-12308	Screen, Turret Tray - Also in Fig. 14	1
16	448-12306	Screen, Rear Exhaust (Back of Cabinet)	1
17	906-00517	Data Plate - 548	1
18	907-00928	Warning Label - "Tighten Screws"	1
19	548-00311	Cover, Refrigeration Unit - R/H Side	1
	448-12205	Refrigeration Unit Assembly - See Fig 16	REF
20	408-01316	Leg, Assembly (Includes Leveler)	4
	934-316	Bolt 12	
21	408-00352	Leveler Only	4
22	548-01509	Power Supply Final Assembly - See Fig. 10	1
	548-01505	Power Supply Cover	1
23	907-02222	Label - "Screen Removal"	1
24	548-01321	Hinge & Pin Assembly - R/H	1
	934-00450	Screw	2
25	907-02217	Label - "Service Switch Instructions"	1
26	907-02193	Label - "Caution Power Supply"	1
27	548-01322	Hinge & Pin Assembly - L/H	1

(Continued on next page)

Cabinet Final Assembly (Continued)

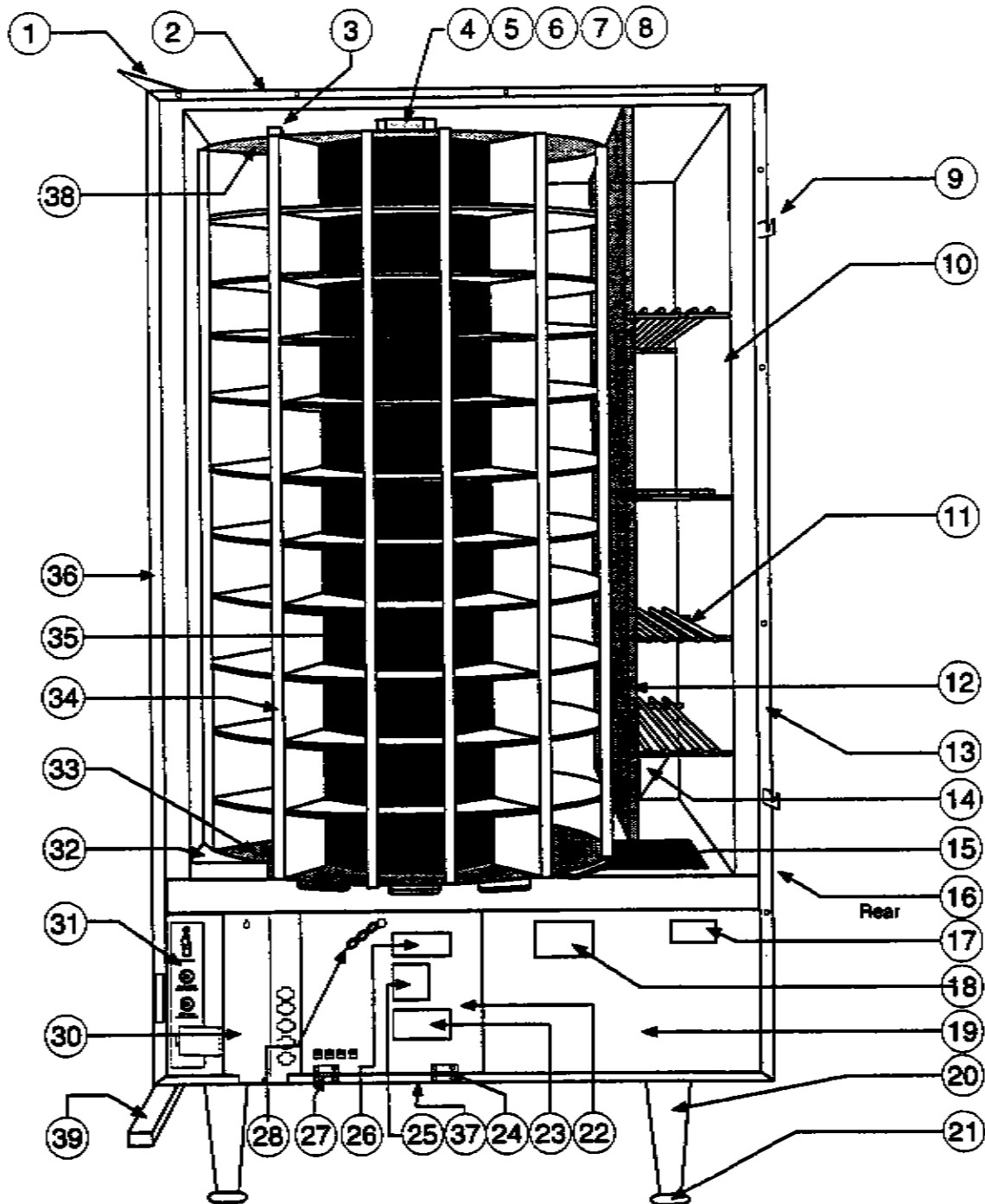

Index No.	Part Number	Description	Quantity Per Assembly
	934-00450	Screw	2
28	448-00935	Chain - Door Stop	1
	921-00365	Screw	1
30	548-00342	Cover - Refrigeration Unit -Left	1
	548-01424	Line Filter Assembly - Export Only	1
	938-05000	Line Filter- Export Only	1
	25166910	Terminal Block- Export Only	1
	548-00524	Bracket - Filter- Export Only	1
	548-01000	Harness Assembly- Export Only	1
	548-00342	Cover- Export Only	1
31	448-12845	Main Switch Power Assembly	1
32	448-00056	Cover - Turret Drive	1
33	448-12600	Main Plate Assembly	1
34	448-00606	Retainer, Shelf	7
	448-00612	Column Separator	7
	934-00486	Screw	14
	941-00078	Speed Nut	7
	941-00077	Speed Nut	7
35	548-01600	Center Column Rivet Assembly - 11 Shelf	1
36	548-00459	Retainer, Liner L/H Side	1
37	548-01308	Condenser Screen W/A (See Fig. 11)	1
	941-00092	Clip, Condenser Screen (Not Shown) (See Fig. 11)	2
38	448-02007	Plate - Turret, Upper	1
39	448-01306	Bracket, Pivot Assembly	1

Product Shelves

448-02601	Split 4"
448-00600	Platter 4 & 5"
448-01607	Over/Under
448-02602	Split 5"
448-02601	Split 4"

Detail 9.1

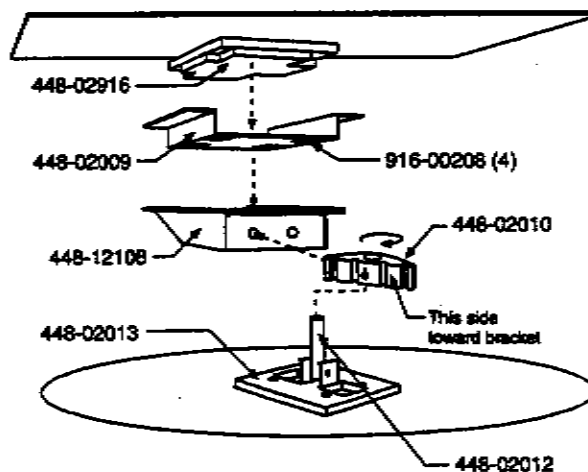

Power Supply Assembly

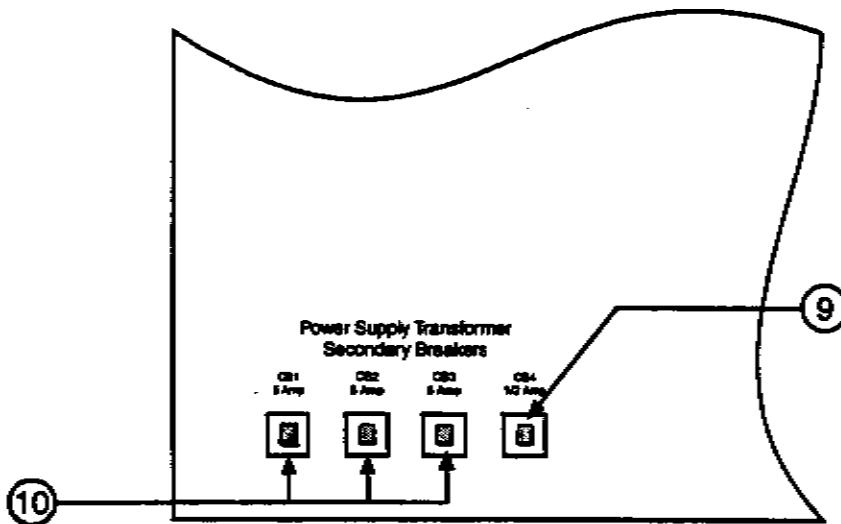
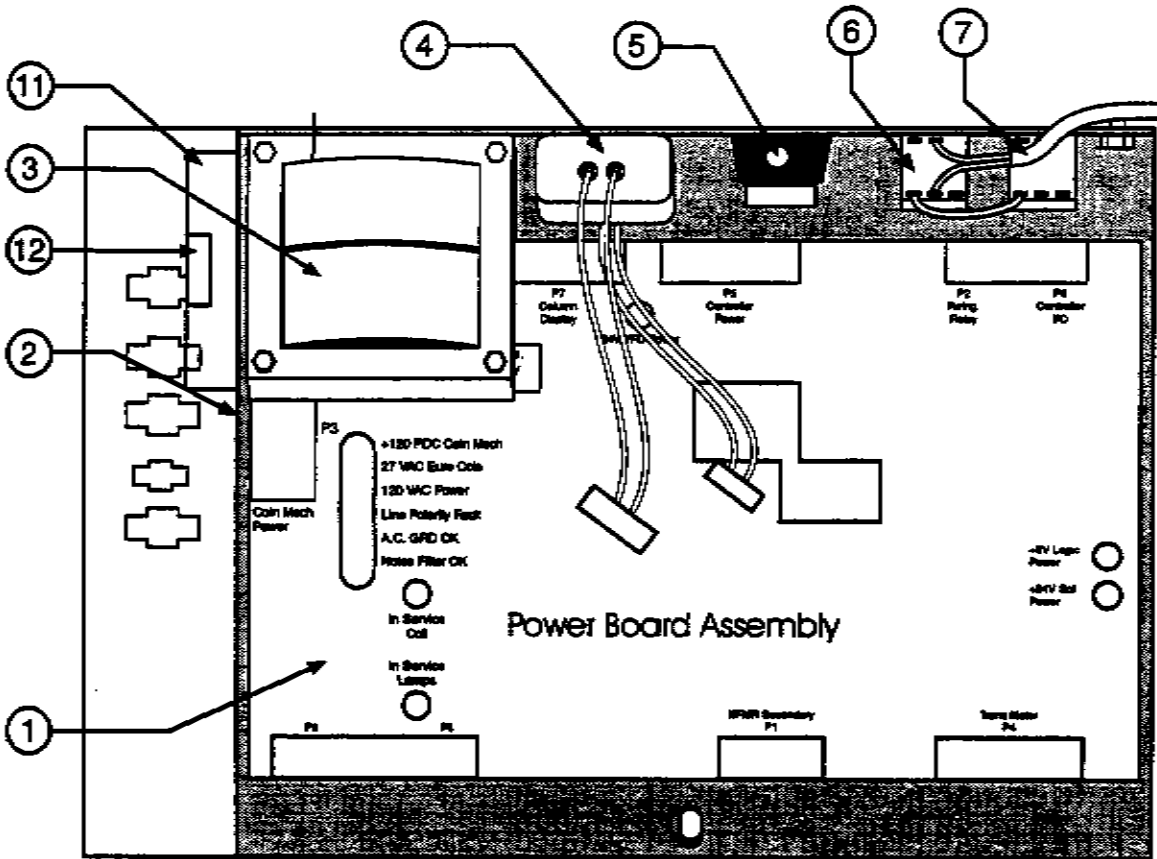

Outside of the Refrigeration Cover
(Power Supply Closed)

Index No.	Part Number	Description	Quantity Per Assembly
	548-01509	Power Supply Assembly - Complete	REF
1	548-01890	Power Supply - Only	1
	280-01101	PCB Assembly - Power Supply	1
	280-70601	Cover - PCB	1
2	548-01508	Cover - Refrigeration Unit	1
3	548-01508	Transformer	1
	924-00054	Nut	4
4	548-01845	Line Filter	1
5	912-00077	Circuit Breaker, 3 Amp	1
	950-00176	Lockwasher	2
6	938-08001	Relay (24 VDC - 15 Amp)	2
	924-00054	Nut	4
7	548-01510	Harness - Power Supply	1
9	700-73601	Circuit Breaker - 1/2 Amp.	1
10	700-73608	Circuit Breaker - 5 Amp.	3
11	548-00828	Cover - Backup Refrigeration	1
12	548-01870	PCB Assembly - Backup Refrigeration	1
	70500004	Support - Circuit Board	4

Main Power Switch

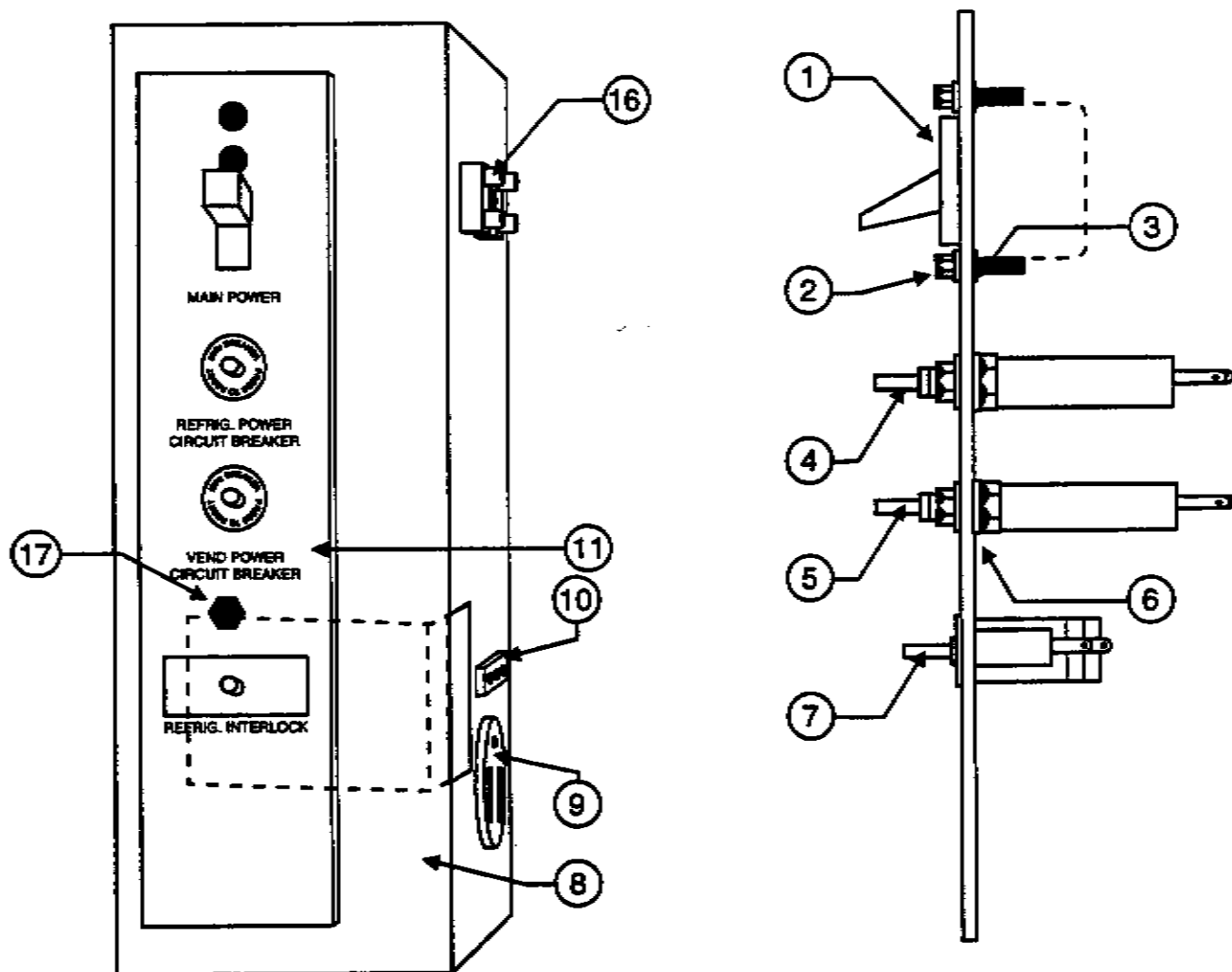

Index No.	Part Number	Description	Quantity Per Assembly
	448-12845	Main Switch Assembly - Complete	REF
	548-21528	Switch Panel Assembly European (Not Shown)	1
1	301-01711	Switch, Main Line	1
	939-01252	Insulation, Fishpaper - Main Line Switch	1
2	921-00287	Screw	2
3	950-00349	Lockwasher	2
4	912-00049	Circuit Breaker, Refrigeration Unit - 20 Amps	1
	912-00046	Circuit Breaker, Refrigeration Unit - 10 Amps (European)	1
5	912-00050	Circuit Breaker, Vend Power - 7 Amps	1
	912-00056	Circuit Breaker, Vend Power - 5 Amps (European)	1
6	950-00112	Washer	2
7	448-12848	Switch, Refrigeration Compressor	1
8	448-02819	Spring, Refrigeration Compressor Switch Actuator	1
9	979-01275	Receptacle, Refrigeration Power Cord	1
10	979-01207	Socket - Vend Circuit Harness Plug	1
11	448-12846	Switch Panel w/ Silkscreen	1

Turret Drive Motor

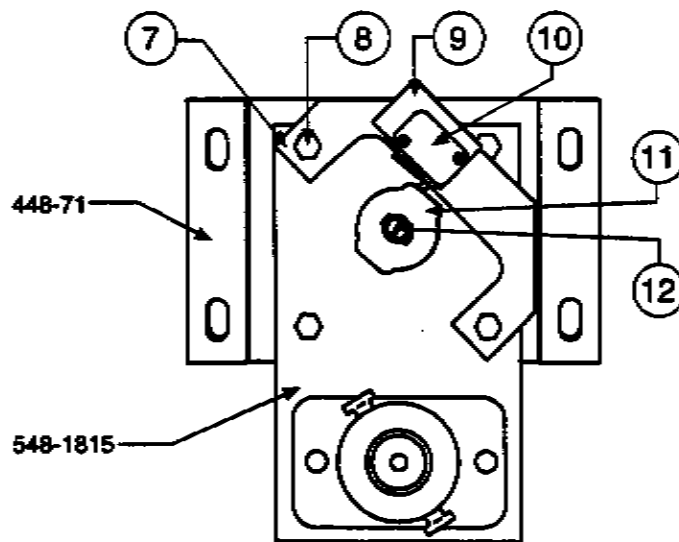
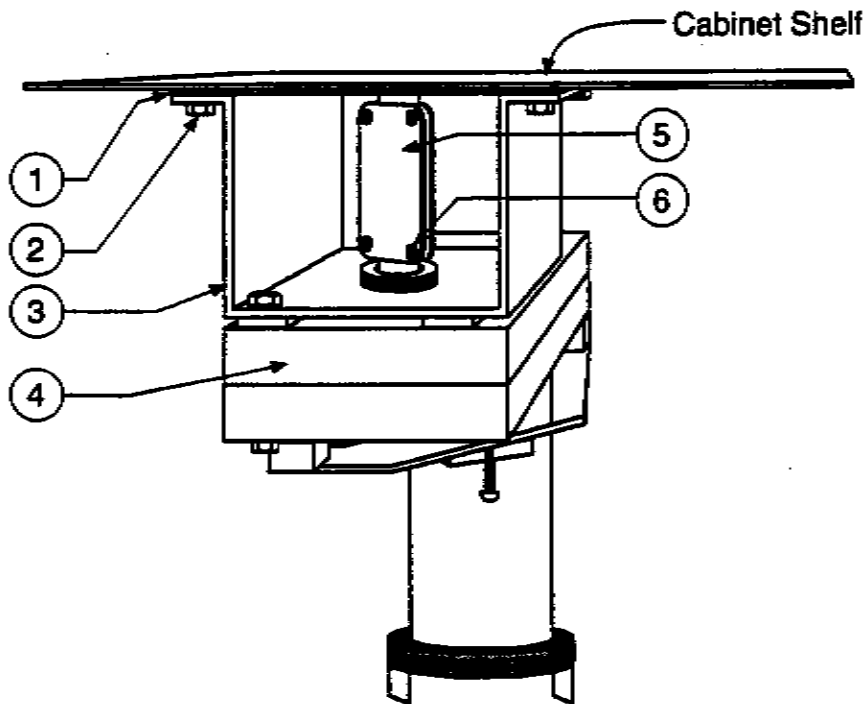

Viewed From Bottom

Index No.	Part Number	Description	Quantity Per Assembly
	548-01814	Drive Motor, Switch and Plate Assembly - Complete	REF
1	448-00041	Plate, Bearing	1
2	934-00199	Screw	4
3	448-00071	Plate, Drive Motor Mounting	1
4	548-01815	Drive Motor and Gear Box, Transport	1
5	448-06022	Coupling Kit	1
	548-01314	Coupling Assembly - Back	1
	448-00085	Coupling - Front	1
	947-00020	Screw	4
	950-00385	Washer	4
	448-00096	Pin, Height Adjustment - (Not Shown)	1
6	947-00020	Screw	4
	950-00385	Washer	4
7	548-00011	Plate, Transport Motor Switch Mounting	1
8	921-00211	Screw	4
	924-00059	Nut	4
9	939-00954	Insulation	1
10	421-04503	Switch, Transport Motor	1
	934-00210	Screw	2
11	448-00087	Cam, Switch Actuator	1
12	921-00309	Machine Screw	1
	950-00052	Washer	1
	924-00054	Nut	1
	548-01838	Harness, Transport Motor and Half Cycle Switch (See Below)	REF
13	913-00031	Fuse Holder	1
	912-00015	Fuse 3.2 Amp	1

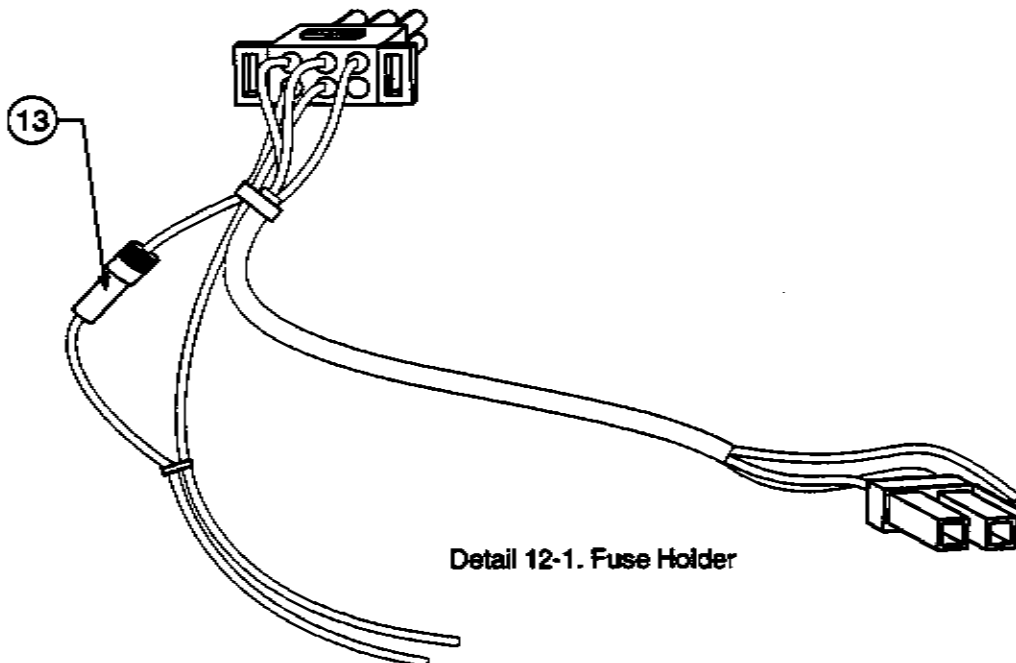

Detail 12-1. Fuse Holder

Turret Components (Bottom)

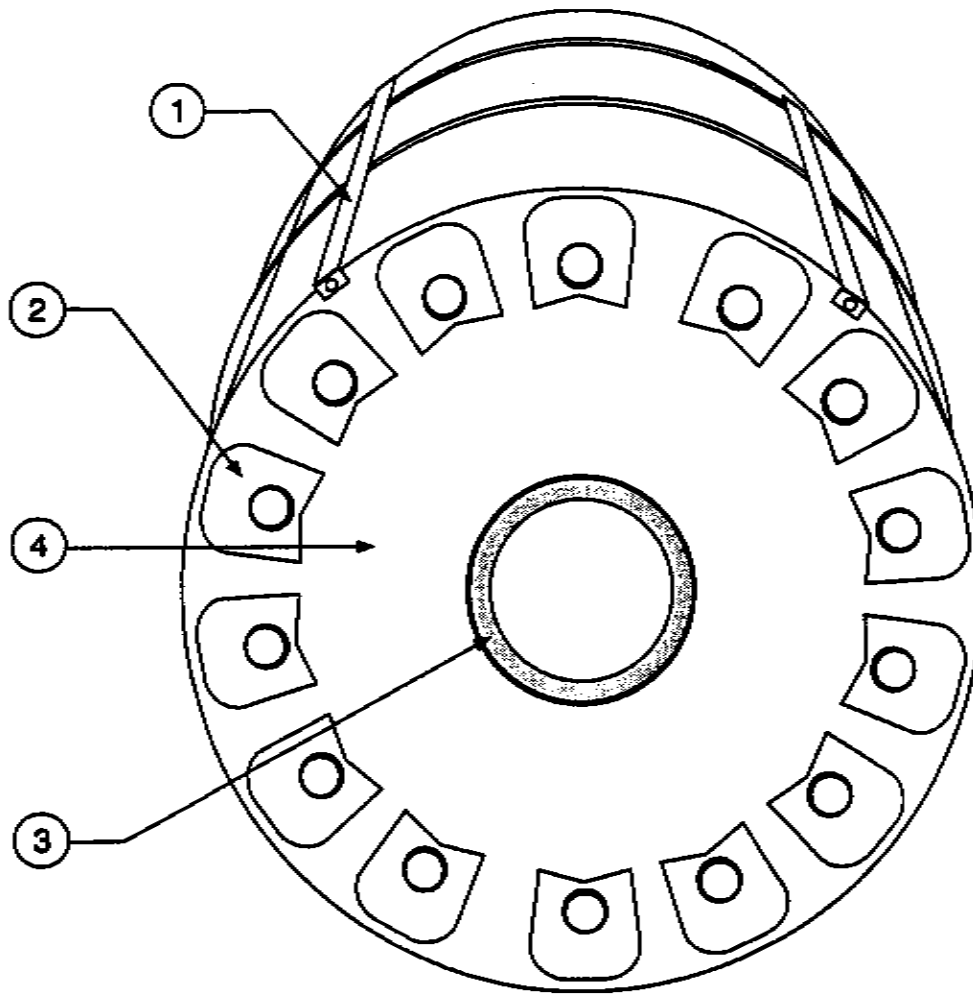

Index No.	Part Number	Description	Quantity Per Assembly
	448-12600	Main Plate Assembly	REF
1	448-00606	Retainer, Shelf	7
2	448-00095	Cam - Turret Drive (Molded)	14
	934-00492	Screw	56
3	448-02002	Ring, Air-Sealed	1
	934-00154	Screw	5
4	448-02600	Plate - Main Turret	1

Turret Drive & Roller

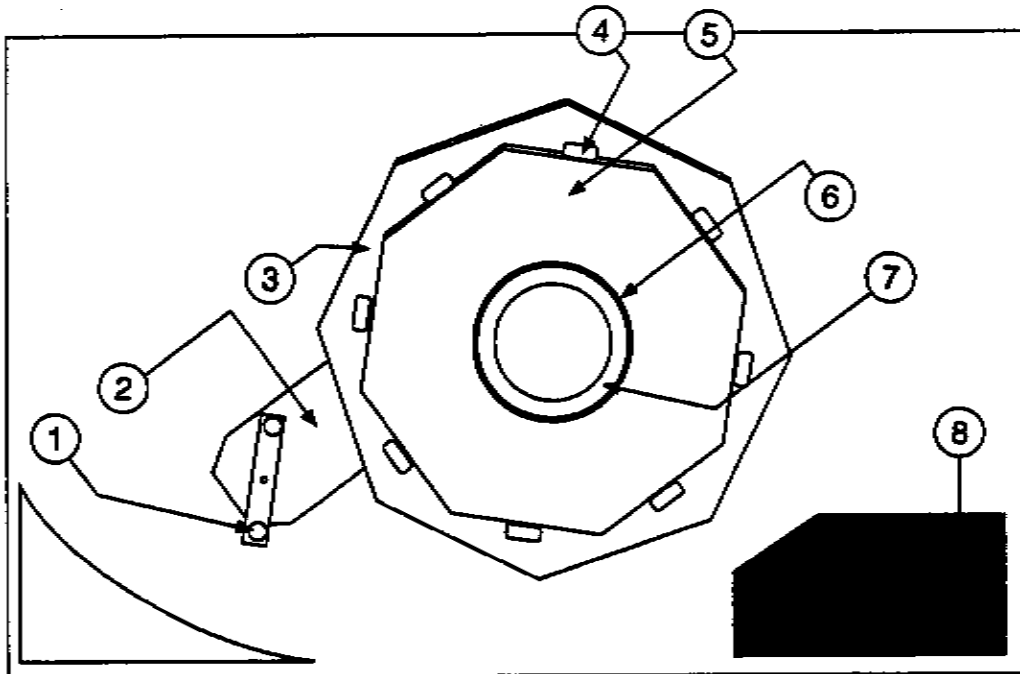

Index No.	Part Number	Description	Quantity Per Assembly
	448-12106	Plate Assembly - Roller Guide	REF.
1	448-01028	Drive Shaft & Bearing Assembly	1
	448-00061	Cam Follower	2
	448-01029	Drive Arm	1
	924-00064	Nut	2
	950-00090	Washer - Flat	2
2	448-01033	Housing & Plate & Bearing Assembly	1
	934-00452	Screw, Self Tapping	3
3	448-12105	Lower Plate Weld Assembly	1
	934-00452	Screw, Self Tapping	7
4	448-00081	Roller	8
	448-00090	Shoulder Bolt	8
5	448-12107	Roller Guide Plate Weld Assembly	1
6	916-00091	Grommet	1
7	448-02001	Ring Turret - Lower	1
8	448-12308	Screen Weld Assembly, Turret Tray - See Fig. 9	1

Lock Bar Solenoid

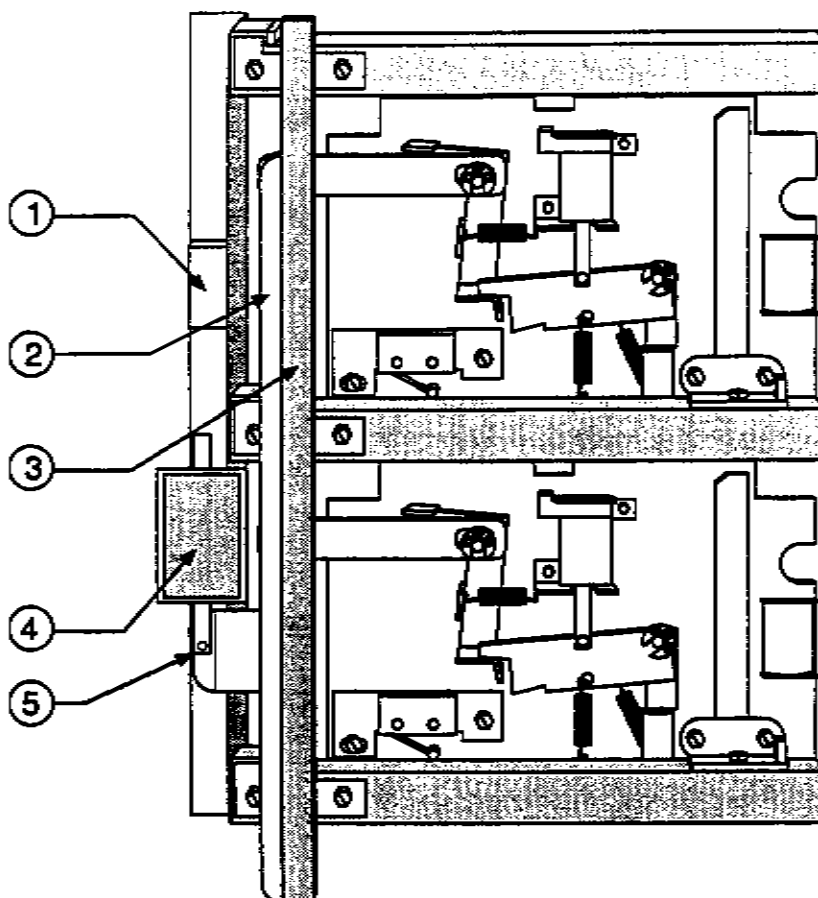

Index No.	Part Number	Description	Quantity Per Assembly
	548-01403	Delivery Door Panel Assembly	REF
1	448-01867	Switch, Lock Bar	2
	934-00125	Screw, Switch Mounting	2
	941-00051	Tinnerman Nut, Switch Mounting	1
	448-000453	Bracket, Lock Bar Switch Mounting	1
	939-00954	Insulator, Fishpaper	1
2	448-01040	Lock Bar Assembly	1
3	548-01854	Solenoid and Diode Assembly, Lock Bar	1
	448-00642	Plate, Solenoid Mounting	1
	934-00307	Screw, Mounting Plate	2
4	448-00722	Anti-Spread Bar	1
5	905-00012	Cotter Pin	1

Refrigeration Unit

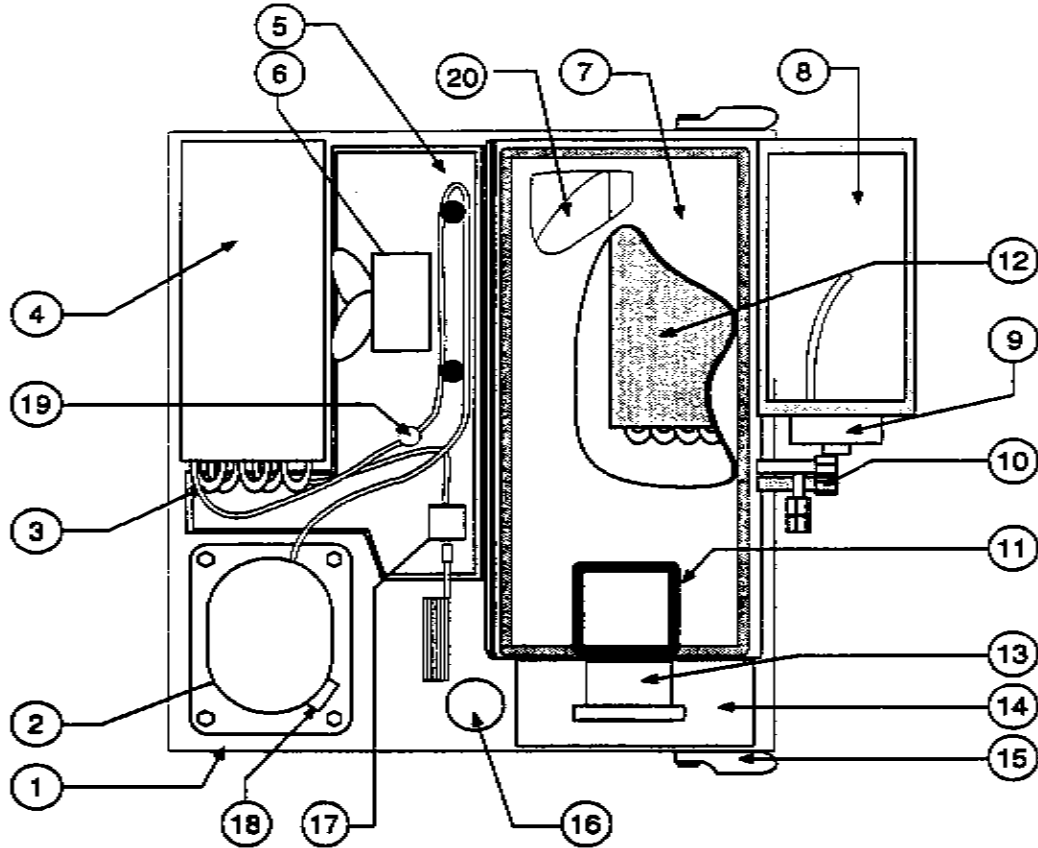

Index No.	Part Number	Description	Quantity Per Assembly
	548-21531	Refrigeration Unit Assembly - Complete, R502 220/240V 50/60 HZ	REF
	548-21559	Refrigeration Unit Assembly - Complete, R404a 220/240V 50/60 HZ	REF
	548-01208 097	Refrigeration Unit Assembly - Complete, R404a 120V 60 HZ	REF
	448-12205	Refrigeration Unit Assembly - Complete, R502 120V 60 HZ	REF
1	448-12209	Refrigeration Unit Base and Stud Assembly	1
2	448-12210	Compressor - R502 120V 60 HZ	1
	548-01207	Compressor - R404a 120V 60 HZ	1
	548-21558	Compressor - R404a 220/240 V 50/60 HZ	1
	548-21524	Compressor - R502 220/240 V 50/60 HZ	1
3	448-12215	Condenser Coil Assembly	1
	866-80005	Gasket, Rubber (Bulk Number)	A/R
		2 Pieces 9 1/4" Long, 1 Piece 13 1/2" Long	
4	448-02225	Shroud, Condenser Unit Assembly	1
5	448-02246	Drip Tray	1
6	448-12221	Condenser Fan Assembly - Complete Consists of:	1
	448-02226	Blade, Condenser Fan	1
	448-01228	Motor, Condenser Fan	1
	448-02215	Bracket, Condenser Fan Mounting	1
	924-00062	Nut, Fan Assembly Mounting	2

Fig. 16**548 Showcase Merchandiser**

Index No.	Part Number	Description	Quantity Per Assembly
7	448-02247	Cover, Evaporator	1
	866-55001	Gasket, Cover (56" Required)	A/R
8	448-12212	Air Return Housing Assembly - Complete	1
	448-02243	Gasket Only - Air Return	1
9	448-01829	Temperature Control Thermostat (Backup Refrigeration) (Not Shown)	1
	595-20501	Cover, Thermostat (Cold Control Backup)	1
10	448-12211	Service Valve Assembly - Complete High Side and Low Side	2
	448-12219	Valve Core Only (Schrader)	2
	448-12220	Cap and Seal - Service Valve	2
11	448-02242	Gasket, Evaporator Output	1
12	448-12225	Evaporator and Bracket R/A (Inside Housing)	1
	448-12216	Evaporator Only	1
	448-02219	Bracket - Evaporator Mounting. (Right)	1
	448-02260	Bracket - Evaporator Mounting. (Left)	1
	929-00043	Rivet	1
13	448-12222	Blower and Bracket Assembly, Evaporator	1
	548-01855	Blower Motor Only	1
	595-21526	Squirrel Cage Only	1
	448-02248	Bracket, Blower Motor Mounting	1
	916-00207	Grommet, Blower Mounting	1
	448-02264	Gasket, Blower	1
14	548-01895	Control Box Assembly - Complete Consists of:	1
	448-02817	Base - Control Box	1
	448-02818	Cover - Control Box	1
	448-12849	Start Relay, Compressor	1
	936-01002	Capacitor, Starting 72-88 mfd. @ 250V	1
	448-02821	Clamp, Start Capacitor	2
	936-01003	Capacitor, Run - 25 mfd. @ 330V	1
	448-02822	Clamp, Run Capacitor	1
	548-01886	Snubber Assembly (In Control Box)	1
	*****	All Harnesses are included in 448-12847 Assembly	
15	448-02241	Lever, Refrigeration Unit Securing	2
	448-02249	Bushing, Lever Pivot	2
	950-00030	Washer	2
	921-00193	Screw	2
16	111-01217	Accumulator, Suction Side	1
17	595-21513	Drier, Liquid Line	1
18	*****	Thermo-Overload - Under Cover (Comes With P/N 448-12210 Only)	1
	****	Start Relay	1
19	70709101	High Pressure Cutout Switch	1
20	44802956	Baffle Evaporator	

Refrigeration Harnesses

448-12867	Harness, Compressor to Cold Control	1
448-12866	Power Cord Assembly - Refrigeration Unit Assembly	1
548-01887	Snubber Assembly (In Evaporator Fan Harness)	1
548-01513	Harness, Thermostat to Refrig. and Backup Relay (Not Shown)	1
548-01896	Harness Evaporator & Condenser Fan	1
548-01897	Harness Compressor & Cold Control	1
548-01898	Harness - Compressor	1

Universal Control Board

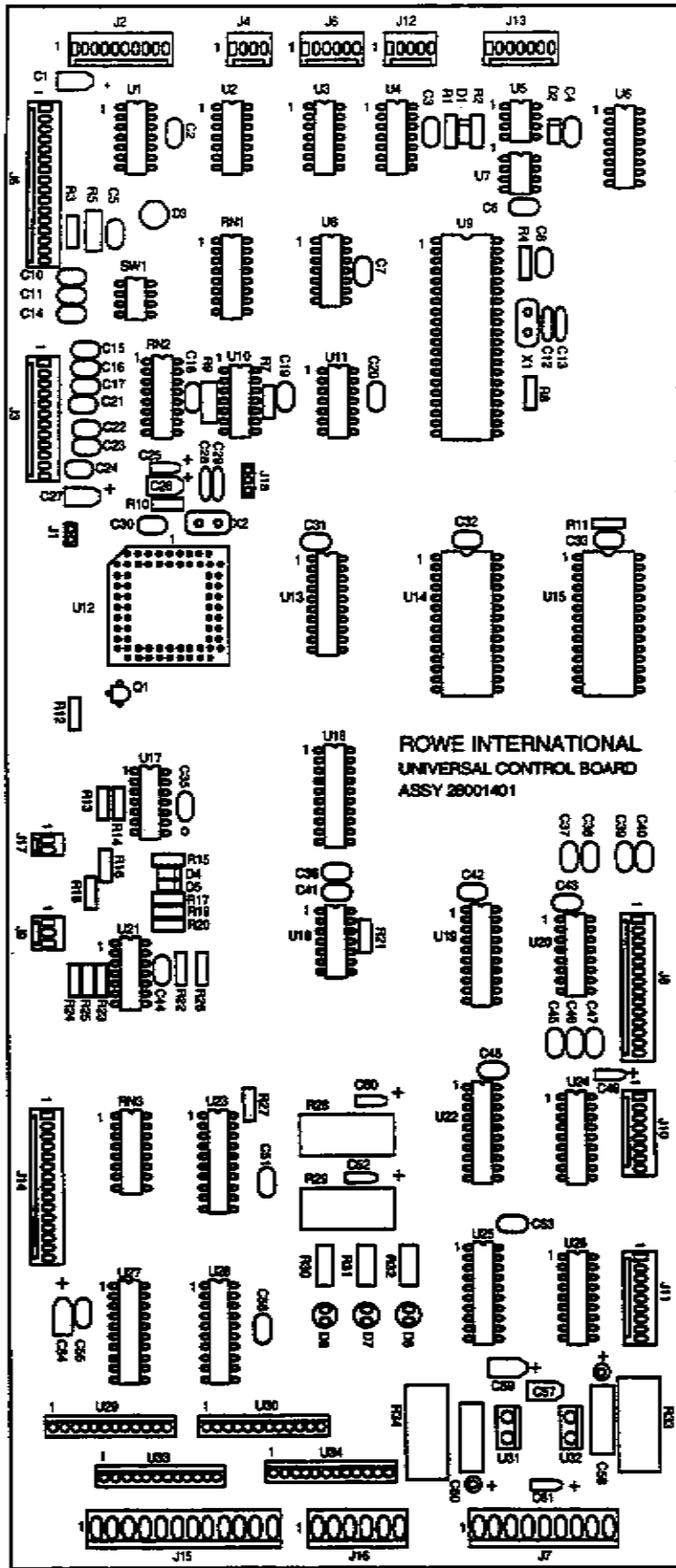

Universal Control Board

Reference Number	Part Number	Description
C58, C60	70028201	Capacitor - 22 μ F, 50V Rad.
C18, C25, C50, C52	70025301	Capacitor - 1 μ F, 35V 10%
C1, C26, C27, C54, C57, C59	70025302	Capacitor - 15 μ F, 15V 10%
C49, C61	70025303	Capacitor - 47 μ F, 10V 10%
C12, C13, C28, C29	70028705	Capacitor - 22PF, 50V 10%
C2-C8, C10, C11, C14-17		
C19-C24, C30-C33, C35-C48		
C51, C53, C55, C56	70028649	Capacitor - .1 μ F, 50V 10%
X2	25167327	Xtal - Quartz, 10 MHz.
X1	25167318	Xtal - Quartz, 3.6864 MHz. LS - .190"
D1, D2, D4, D5	70035012	Diode 75V .075 Amp.
U21	30800270	IC - Quad 2 input,
U17	30800216	IC - Quad OP Amp.
Q1	30800243	IC - Under Volt Sensor
U18	79940008	IC - Quad 2 input and Gate CMOS
U10, U11	79940014	IC - Hex Schmitt-Trig Inverter CMOS
U6	79940157	IC - Quad 2 input Multiplexer
U19, U22, U25, U27, U28	79940273	IC - Octal D-Flip Flop w/Clear
U13	79940573	IC - Octal D-Latch Tri-State
U5	70033714	IC - 2 Channel Optocoupler
U20	70036901	IC - Darlington Array
U24, U26	70036906	IC - High Current Source Driver
U29, U30, U33, U34	70036908	IC - Quad - High Current, Darlington
U2, U3	30800271	IC - Quad Line Driver
U4, U8	30800272	IC - Quad Receiver
U9	70034704	IC - Dual Uart
U15	70036609	IC - SRAM Bat. 8K x 8 w/RTC
U16	28027101	IC - UCB - Programmed
U23	70037145	IC - Encoder, Priority IDPE-30
U1	70036309	IC - Hex Buffer Open
U32	70036518	IC - Voltage Regulator, 12V Linear
U31	70036521	IC - Voltage Regulator, -12 to -200
R16	799122322	Resistor - 23.2K 1/4 Watt 1%
R13	799123462	Resistor - 34.8K 1/4 Watt 1%
R14	799121003	Resistor - 100K 1/4 Watt 1%
R15, R17-R20, R22-R26	799121004	Resistor - 1M 1/4 Watt 1%
R12	799124990	Resistor - 499 OHM 1/4 Watt 1%
R3, R7, R8, R10, R11, R21	799001123	Resistor - 12K 1/4 Watt 5%
R5, R9, R32	79904391	Resistor - 390 OHM 1/2 Watt 5%

Universal Control Board (Continued)

Reference Number	Part Number	Description
R30, R31	79904392	Resistor - 3.9K 1/2 Watt 5%
R28, R29, R33, R34	70714201	Resistor - 20 OHM 5 Watt 5%
SW1	70043008	Switch - Dip
D3, D6-D8	70035303	LED - Visible, Red
U7	7994040107	IC - Dual 2 Input Nand GT, CMOS
J2	70076410	Connector - HDR, 10 Position
J3	70076412	Connector - HDR 12 Position
J4	70076404	Connector - HDR 4 Position
J5	70076416	Connector - HDR 16 Position
J7	70080509	Connector - HDR 9 Position
J9	70076403	Connector - HDR 3 Position
J13	70076407	Connector - HDR 7 Position
J6	70076406	Connector - HDR 6 Position
J8	70076414	Connector - HDR 14 Position
J10	70076408	Connector - HDR 8 Position
J11	70076409	Connector - HDR 9 Position
J12	70076405	Connector - HDR 5 Position
J14	70076415	Connector - HDR 15 Position
J15	70080512	Connector - HDR 12 Position
J16	70080506	Connector - HDR 6 Position
J17	70076402	Connector - HDR 2 Position
J18	70078703	Connector - HDR 3 Position
R1, R2	79901181	Resistor - 180 OHM 1/4 Watt 5%
R4, R27	79901102	Resistor - 1K 1/4 Watt 5%
XU15	70073929	Socket - IC
XU-12	25236201	Socket - IC
XU14	70073928	Socket - IC

Power Supply Circuit Board Assembly

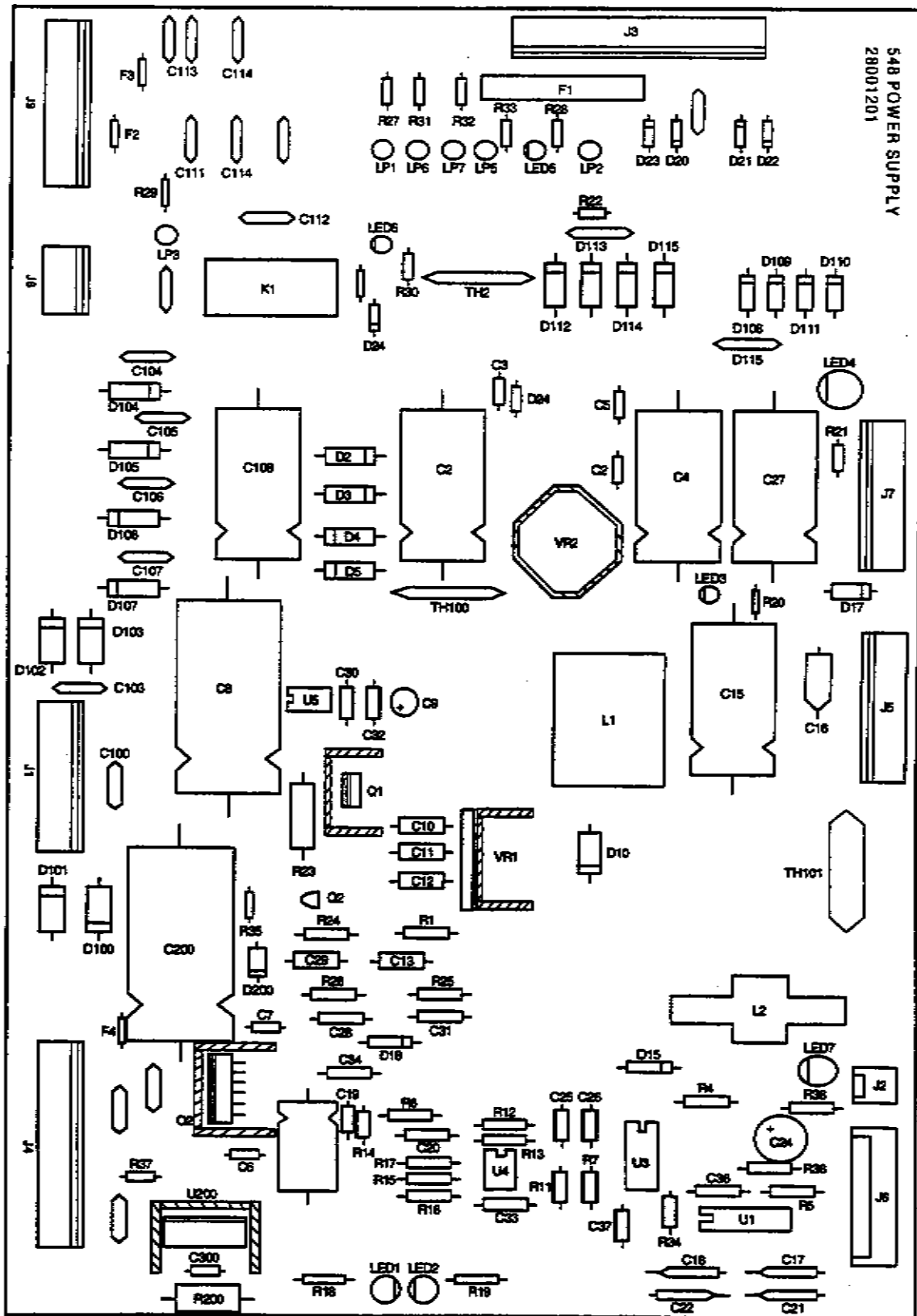

Components List

Power Supply Circuit Board

Reference	Description	C-Power P/N	Mfg Part Number
Q1	XSTR. NPN 60V 3 Amp	700033005	Motorola 2N6121
U2	IC, H-Bridge Motor Driver	230A-00LM18200T	Nat'l. Semi. LMD182OCT
U200	IC, Volt Reg. Adj. Neg. 3A to 220	230A-0000LM 350T	Motorola LM35CT
VR1	PWM 5V	230A-OLAS6330PI	Aavid 593002BC340C
VR2	IC Volt. Reg. Adj. 5A to -3	230A-0000LM338K	Nat'l. Semi. LM 338K
F1	Fuse Holder	461A-250600-001	Shurter CG 751.0099
D17	Diode 6V	221A029-00ICTE5	Gen. Semi. ICTE-5
P2, P3	Fuse 1Amp 125 VAC	262A1R00125A-01	Littlefuse 251CCI
C35	Cap. 220 MFD 50V 20%	203A7F6100-2207	Panasonic ECEE1HV102S
C2, C4, C27, C108	Cap. 1000 MFD 50V 20%	203A7F6100-1008	Panasonic ECEE1HV102S
C8, C200	Cap. 4700 MFD 50V 20%	203A7C6100-4708	Panasonic ECEE1HU472S
C15	Cap. 2200 MFD 15V 20%	203A7F6100-2208	Panasonic ECEE1CF222
C16, C18, C21 C22, C31	Cap. 15UF 15V 10%	70025302	Sprague 173D156X9015W
C9, C24	Cap. 47UF 63V 20%	203A7T6000-4706	Sprague 515D476M100CD6A
C13	Cap. 120 PF 100V 10%	203A0F5110-1201	AVX SA101A121KAA
C10	Cap. 5600PF 100V 10%	203A0H5120-5602	AVX SA101C562KAA
C11, C12, C20, C23 C28, C30, C32, C33 C34, C36, C37, C300	Cap. .1UF 50V 20%	70028649	Kemet C410C104M55U5CA
C3- C7, C25 C26, C29	Cap. .01UF 100V 10%	203A0H5120-1003	AVX SA201C103KAA
C100-C107, C111, C112	Cap. .01UF 1KV 20%	203A9R6070-1003	MPI GE103M
D15	Diode, signal 75 PIV	70035012	Diodes, Inc. 1N4148
D20-D23, D24 D108-D111	Diode, 400V 1A DC-41	70035005	Diode, Inc. 1N4004
D10	Diode, Schottky 40V	220A004-C1NS822	Motorola 1N5822
C19	Cap. .68UF 35V 10%	203A6E5100-6804	Sprague 173D684X9035V
C113, C114	Cap. .001UF 1KV 20%	203A0R7091-1001	Sprague 5GAD10
D104, D105 D106, D107	Diode, Rect. 50V 6A	220A028-00006A1	Rectron 6A1
D18	Zener 5.1V 70035501	Motorola 1N4733A	
F1	Fuse 2Amp 125V	262A2R000125D-01	Littlefuse 312002
J2	Con. HDR. MTA100	350A06404563-00	AMP 640456-3
J6	Con. HDR. MTA100	350A16404562-00	AMP 1-640456-2
D2, D3, D4, D5, D100-D103, D112, D113 D114, D115, D200	Diode, Rect. 100V 3A	70035004	Diodes, Inc. 1N5401
J9	Con. HDR. MTA156	350A06404458-00	AMP 640445-8
J1	Con. HDR. 7 Pin .156 Centers	350A06404457-00	AMP 640445-7
J7	Con. HDR. MTA156	70080509	AMP 640445-9
J5	Con. HDR. MTA156	350A16404450-00	AMP 1-640445-0
J4	Con. HDR. MTA156	350A16404453-00	AMP 1-640445-3
U4	IC LM10CN OP-AMP	230A-0000LM10CN	National LM10CN
U5	IC, Overvoltage Sens.	230A-000003423P	Motorola MC3423R1
U3	IC, Digital Guad.	232A-000074HC02	National Semi. MM74HC02N
U1	IC, RS232	230A-00IT1181CN	Linear Tech LT1181CN
L2	Inductor, 1MH 4A	206A1-1005-0001	Dale IH-3-01
L1	Inductor, 220MH 5.5A	206A3-2207-0001	Renco RL-4435-285-3.0

Components List Power Supply Circuit Board

K1	Relay, 24VDC 10 Amp	244AGR2117P-VUS	OMCRCN G2R-1A-D024
R26	Resistor, 681 .25W 1%	200A005002-6810	TTI 5043ED681R0F
R25	Resistor, 866 .25W 1%	200A005002-8660	TTI 5043ED866R0F
R21	Resistor, 56 .25W 5%	79901560	Philips 5043CX56R00J
R7, R8, R11, R12	Resistor, 100 .25W 5%	79901101	Philips 5043CX100R0J
R9	Resistor, 220 .25W 5%	79901221	Philips 5043CX220R0J
R19	Resistor, 270 .25W 5%	79901271	Philips 5043CX270R0J
R24	Resistor, 1K .25W 5%	79901102	Philips 5043CX1K000J
R30	Resistor, 1.5K .25W 5%	79901152	Philips 5043CX1K500J
R13, R22, R37	Resistor, 1.8K .25W 5%	79901182	Philips 5043CX1K800J
R18, R20, R35, R38	Resistor, 1K .25W 5%	79901222	Philips 5043CX2K200J
R5, R6, R14, R34	Resistor, 4.7K .25W 5%	79901472	Philips 5043CX4K700J
R1	Resistor, 22K .25W 5%	79901223	Philips 5043CX22K00J
R15, R17, R27, R28 R29, R33	Resistor, 100K .25W 5%	79901104	Philips 5043CX100K0J
R10, R16	Resistor, 1M .25W 5%	79901105	Philips 5043CX1M000J
R200	Resistor, .47 5W 10%	200A042044-SX47	Dale CP5 - .47 - 10%
R23	Resistor, 180 5W 10%	200A042044-0181	IRC PW - 5A - 180 - 5%
Q2	Thyristor 60V .51 Amp	266A4-0002N5061	Motorola 2N5061
TH2, TH100, TH101	Thermistor	215A-00RDE-305A	Raychem RDE-305A
R31, R32	Resistor 330k .25W 5%	79901334	KOA RDS2 - 1/4 - 330K-5%
F2	Fuse 1 Amp 125V	262A1R00125A-01	Littlefuse - 251001
F3	Fuse 1 Amp 125V	262A1R00125A-01	Littlefuse - 251001
F4	FUSE 3 Amp 125V	262A3R00125A-01	Littlefuse 251.003
LED5	LED Red / Green	242A-01F02AS-01	Qual. Tech. MV5491
LED1, LED2, LED3, LED4, LED6, LED7	LED Red	242A-01F022S-01	Lite On LTL-4203
LP1, LP2, LP3, LP5 LP6, LP7	Lamp, Neon Blue	240A-CA1201B-01	Alco NE - 1H
R4	Resistor, 4.75K .25W 1%	200A005002-4751	PHILIPS 5043ED4K750F
J8	CON. HDRMTA-156	350A06404454-00	

Harness List

Internal Harness Assemblies

548-01835	Harness - Door Power Panel
548-01891	Harness - Transformer Assembly
548-01014	Line Cord with Terminal (Main Power Cord)
916-00108	Grommet (Line Cord)
500-01017	Harness - Mess. Center Disp. to Mess. Center Keypad

Point to Point Harnesses

	From	TO
548-01819	Harness - Universal Control Board	P-2 Message Display Center
548-01820	Harness - Universal Control Board P-3	Door Switches
548-01822	Harness - Universal Control Board P-5	UBA, P-3
548-01825	Harness - Universal Control Board P-8	Coin Mech Socket
548-01826	Harness - Universal Control Board P-9	Health Probe Socket
548-01827	Harness - Universal Control Board P-14	Delivery Door Switches
548-01828	Harness - Universal Control Board P-15	Door Solenoid
548-01832	Harness - Power Panel	Bulb Socket
548-01833	Harness - Door Power	UBA Power
548-01874	Harness - Door Panel	Blower and Heater
548-01838	Harness - Half Cycle Sw./Transport Mtr.	Connector
548-01839	Harness - Ballast	Door Power Panel
548-01511	Harness - Control Door	Cabinet
548-01512	Harness - Door Power	Cabinet
548-01884	Harness - UCB P16	Solenoid Driver Protection
548-01510	Harness - Power Supply	Power Supply
548-01513	Harness - Cold Control	Power Supply

European Part Numbers

548-20500	Bezel - Coin Insert, Universal Control
548-20501	Plate - Mounting, Coin Mech, Europe
548-20502	Chute - Coin Return, Front, Europe
548-20503	Chute - Coin Return, Rear, Europe
548-20504	Bracket - Trans Mounting, Europe
548-20505	Bracket - Trans Retaining, Europe
548-20509	Overlay - Bezel, Selection, Charcoal Brown, UBA
548-20510	Overlay - Bezel, Selection, Black, UBA, French
548-20511	Overlay - Bezel, Charcoal Brown, German
548-20512	Overlay - Bezel, Black, German
548-20513	Overlay - Bezel, Universal, Brown, Spain
548-20514	Overlay - Bezel, Universal, Black, Spain
548-21500-001	Cabinet Final Assembly, European
548-21500-002	Cabinet Final Assembly, English
548-21501	Cabinet Assembly - European / English
548-21520	Door Final Assembly - European
548-21521	Door, Coin Mech - European
548-21522	Plate - Mounting Weld Assembly, European
548-21523	Hinge Assembly - Mounting Bracket, Coin Mech, European
548-21524	Compressor - European
548-21525	Motor - Condenser Fan, European
548-21526	Relay - Start, European
548-21529	Fan Assembly - Condenser, European
548-21530	Refrigeration Assembly, European - R502
548-21559	Refrigeration Assembly, European - R404a
548-21531	Compressor Assembly, European - R502
548-21558	Compressor Assembly, European - R404a
548-21534	Transformer and Bracket Assembly, 220V
548-21535	Panel, Switch and Silk Screen Assembly, European
548-21536	Isolation Transformer 750V AC
548-21537	Capacitor / Relay Box Assembly, European
548-21539	Power Cord - Compressor, European
548-21540	Harness, Evaporator and Condenser Fan - European
548-21542	Door - Coin Mech, Rivet Assembly, European
548-21543	Harness - Coin Mech Power, European
548-21545	Line Cord Asm.
548-21546	Hinge Assembly - Coin Mech Mounting Bracket
548-21547	Coin Mech Mounting Bracket

Hardware List

Part Number	Description
448-00090	Shoulder Bolt
903-00005	Carriage Bolt 1/4-20 x 5/8
903-00016	Carriage Bolt - 10-24 x 5/8
905-00012	Cotter Pin 1/8 X 3/4
905-00051	Hitch Pin 3/16
914-00007	Push Fastener
921-00026	Machine Screw - 10-32 x 3/4 RD
921-00037	Machine Screw - 6-32 x 3/16 BD
921-00193	Machine Screw - 1/4-20 x 1" Hex Head
921-00211	Machine Screw - 6-32 X 3/16 BD
921-00240	Machine Screw - 10-32 x 1/4"
921-00287	Machine Screw - 6-32 x 5" Hex Head Washer
921-00309	Machine Screw - 8-32 X 1 1/2 FIL
921-00310	Machine Screw - 8-32 x 5/16" Hex Head
921-00365	Machine Screw - 10-32 x 1/2 HX
921-00496	Machine Screw - 1/4-28 x 3/4 FLT
924-00006	Nut - 10-32 Type 1
924-00037	Nut - 10-24 Type 1
924-00054	Nut - 8-32 Type 6
924-00062	Nut - 1/4-20 Type 6
924-00064	Nut - 1/4-28 Type 6
924-00160	Nut 5/16-18 Type 25
924-00176	Nut - 3/16 Stud Type 11
924-00181	Nut 1/2-20 Type 4
929-00154	Rivet 1/8 x 1/4 Truss
933-00004	Retaining Ring - Type 10 - G=.250
933-00005	Retaining Ring - Type 10 - G=.187
934-00029	Screw - Self Tapping, #8 x 3/8" Type Z Hex Head
934-00077	Screw - Self Tapping, 6 x 3/16, Type-Z,STV
934-00151	Screw - Self Tapping, #8 x 1/4" Type Z Hex Washer Head
934-00154	Screw - Self Tapping, 8 x 3/8, Type Z Hex Washer Head
934-00199	Screw - Self Tapping, 10 x 3/8, Type Z Hex Head - Sems
934-00210	Screw - Self Tapping, 4-40 x 5/8, Type - 23,Hex
934-00250	Screw - Self Tapping, #6 x 1/4" Type Z Hex Washer Head - Sems
934-00291	Screw - Self Tapping, 5/16-18X1, Type - 23,Hex Washer Head
934-00307	Screw - Self Tapping, #8 x 3/8" Type Z Hex Washer Head - Sems
934-00317	Screw - Self Tapping, 8-32 x 5/16" Type 23 Hex Washer Head
934-00320	Screw - Self Tapping, 6-32 x 5/16" Type 23 Hex Washer Hd-Sems
934-00324	Screw - Self Tapping, 8-32 x 5/16, Type 23 Hex Washer Hd - Sems
934-00350	Screw - Self Tapping, 8-32 x 5/8, Type 23 Hex Washer Head

Hardware Lis (Continued)

934-00357	Screw - Self Tapping, 8-32 x 5/16, Type A Hex Washer Head - Sems
934-00383	Screw - Self Tapping, 8-32 x 3/8, Type - 23, FLT
934-00419	Screw - Self Tapping, 8-32 x 3/8" Type 23 Hex Washer Head
934-00428	Screw - Self Tapping, #8 x 3/8" Type Z Truss
934-00443	Screw - Self Tapping, #8 x 1-3/8" Type Z Truss
934-00448	Screw - Self Tapping, 8-18 x 1/2, Type-AB, Truss
934-00450	Screw - Self Tapping, 10-24 x 5/8, SLFDRL, Hex Washer Head
934-00452	Screw - Self Tapping, 10-9 x 3/4, LOTORQ., Hex Washer Head
934-00457	Screw - Self Tapping, #8X3/8, Type - Z, Truss
934-00458	Screw - Self Tapping, #8 x 5/8" PLT 30 Truss Hex Washer Head
934-00485	Screw - Self Tapping, #8 x 3/8" Type Z Truss Nib
934-00486	Screw - Self Tapping, 8 x 15/32, Type - Z, Truss Head Nib
934-00492	Screw - Self Tapping, 8 x 5/8, TY-Z, TRUSS
934-00508	Screw - Self Tapping, #8 x 5" Type 1 Truss
941-00008	Nut - Speed, Type 6 for 1/8" Stud
941-00051	Nut - Speed, Type -5 for #4 Screw
941-00077	Nut - Speed, Type - 26 for #8 Screw
941-00078	Nut - Speed, Type - 23 for #8 Screw
941-00092	Clip - Screen
947-00020	Screw - Socket Set 10-32 x 7/8 Type 2
950-00005	Washer - 1/4" Flat
950-00015	Washer - #8 Flat
950-00030	Washer, # 1/4, Flat
950-00045	Washer, #6, Flat
950-00052	Washer - #8 Flat
950-00090	Washer - Flat
950-00112	Washer, # 1/4, Flat
950-00226	Washer - Locking
950-00344	Washer - #8 Locking
950-00349	Lockwasher - 8 split
950-00383	Washer - .251 Square Hole
950-00385	Washer #10 Lock
975-00103	Clip -Type 5, Nylon , D= 1/2
975-00552	Tie -Type 16, Nylon
975-00602	Clip -Type 5, Nylon , D= 13/16

