

Hot Drink Module Setup, Operation and Service Manual



12955 Enterprise Way
Bridgeton, MO 63044-1200
(314) 298-3510

What is this booklet for?

Since your merchandiser came equipped with a hot drink section, the Main Setup Guide has instructed you to get this booklet to continue your setup. Follow the steps for setting up your hot drink section, then return to the spot in the Main Setup Guide that sent you here. Afterwards, you can return to this book for the day-to-day operating and maintenance information to keep your hot drink section working its best.

DON'T THROW THIS BOOKLET AWAY !! It's a valuable reference for your daily maintenance. Put it back in the plastic bag and store it inside the cabinet. That way, it is readily available at a future time.

Hot Drink Module Setup, Operation and Service Manual

TABLE OF CONTENTS

Water Service	2
Water Supply:	2
Water Pressure Requirements:	2
Flushing Water Supply Line:	2
Supply Line Requirements:	2
To Connect the Merchandiser to the Supply Line	2
Using a Water Filter Cartridge:	2
How to Turn the Merchandiser On and Off	3
Initial Setup	3
1. Remove the Canisters	3
2. Remove Two Trays	4
3. Install the Water Filter Cartridge	5
4. Install the Water Inlet Elbow	6
5. Adjust the Hot Drink Price Labels	6
6. Adjust the Cup Mechanism	7
7. Load the Cup Mechanism	9
8. Adjust the Cup Deflector	9
9. Load the Dry Ingredient Canisters	10
10. Connect the Water Heater Harness	11
11. Replace the Two Trays	12
12. Replace the Canisters	13
Where to Find Maintenance Procedures	14
Water Measurement and Adjustment	15
Setting Water Time	15
Collecting Water Throws	16
Adjusting the Water Valves:	16
Table A: Suggested Water Times	16
Table B: Suggested Water Volume	16
Measuring and Adjusting Dry Ingredients	17
Setting Brewed Selection Throw:	17
Setting Hot Chocolate, Sugar, and Whitener Throw:	17
Table C: Suggested Ingredient Times	18
Table D: Recommended Ingredient Weights	18
Air Pressure Adjustment	19
Water Filter Cartridge Removal	20
Water Filter Cartridge Replacement	20
Overall Cleaning	21
Sanitation	22
Identification of Brewer Components	23
Removing the Brewer Barrel and Manifold	24
Disassembling the Brewer Barrel and Manifold	24
Brewer Basket Removal	24
Brewer Basket Replacement	24
Brewer Basket Screen Removal	24
Cleaning the Brewer Basket Screen and Brewer Barrel Screen	25
Brewer Basket Screen and Brewer Barrel Screen Replacement	25
Brewer Barrel and Manifold Reassembly	25
Brewer Barrel and Manifold Replacement	25
Brewer Funnel Removal	25

Hot Drink Module Setup, Operation and Service Manual

Brewer Funnel Replacement	25
Brewer Mechanism Cleaning	26
Brewer Timing Adjustment	27
Cup Delivery Compartment Removal and Replacement	28
Cup Delivery Compartment Sanitizing	28
Beverage Discharge Nozzle Sanitizing	28
Vent Blower Filter Removal and Replacement	28
Grounds Pail Cleaning	29
Waste Pail Sanitizing	29
Water Filter Cartridge Service Limits	29
Measuring and Setting Water Temperature	29
Dry Ingredient Air Fluffing	30
Sugar and Whitener Mixing Bowl Inspection	30
Dry Ingredient Shelf Cleaning	30
Canister Sanitizing	30
Mixing Bowl Sanitizing	30
Chocolate Funnel and Impeller Housing Sanitizing	31

Hot Drink Module Setup, Operation and Service Manual

Interior View

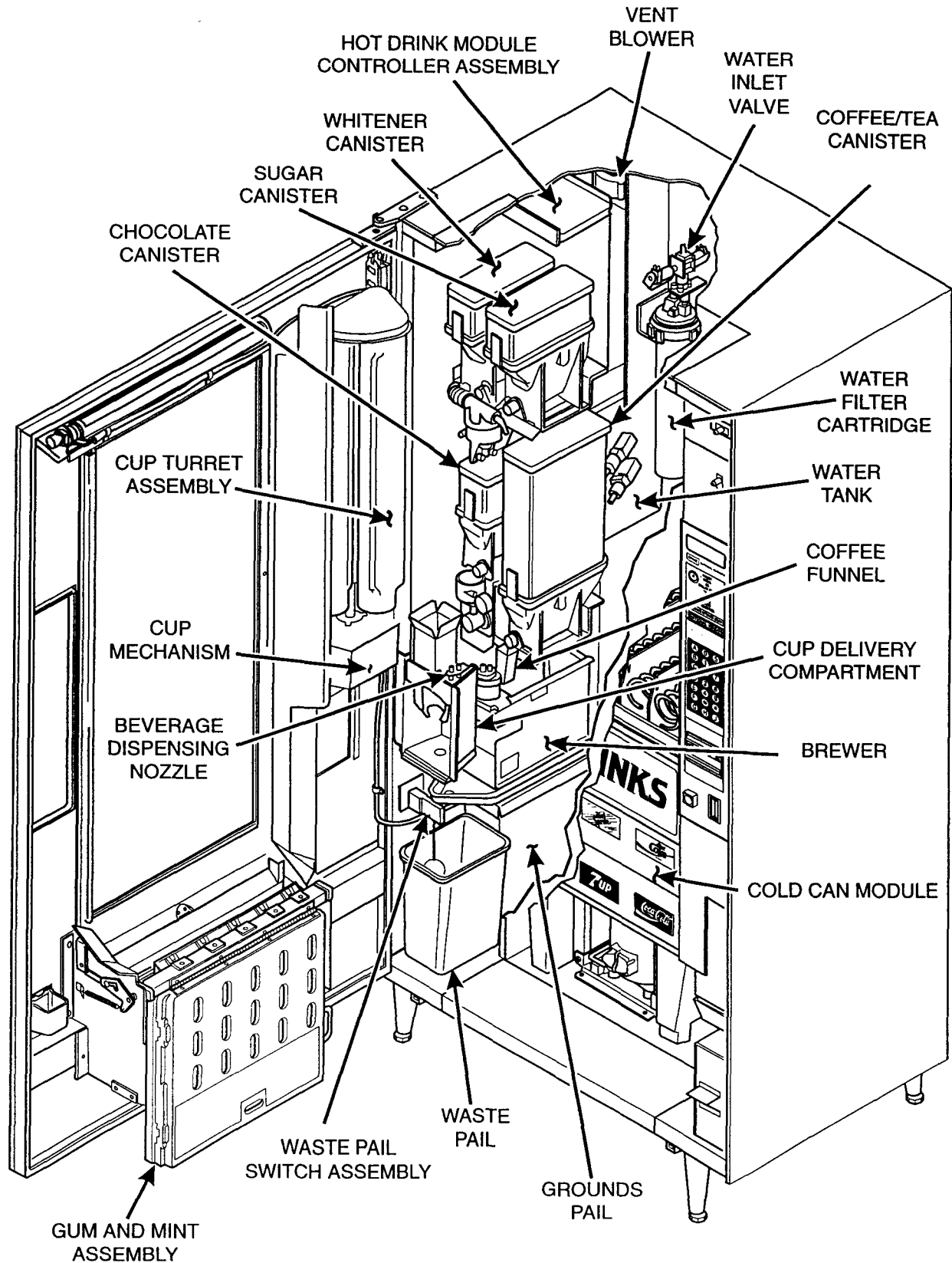

Hot Drink Module Setup, Operation and Service Manual

Water Service

WATER SUPPLY:

The best type of water for coffee brewing is normal hard water.

If your location has chemically softened water, one of the following steps is advised:

- Have a non-softened supply line run to the merchandiser.
- Contact your local water filter supplier for information and suggestions.

Well water can also be used in your merchandiser. However, you should have it checked for levels of carbonates and alkalies. Contact your water filter supplier if these values are relatively high.

WATER PRESSURE REQUIREMENTS:

Minimum water pressure: 10 psi (69.0 kPa) at ½ gallons per minute.

Maximum water pressure: 80 psi (522.0 kPa) at ½ gallons per minute.

FLUSHING WATER SUPPLY LINE:

Flush the water supply line before connecting it to the merchandiser. A minimum of five gallons is usually required before connecting the merchandiser to the supply line. DO NOT flush the merchandiser water system.

SUPPLY LINE REQUIREMENTS:

Locate the supply line so it will be behind the merchandiser and equip it with a shut-off valve.

TO CONNECT THE MERCHANDISER TO THE SUPPLY LINE:

You will need the following:

- A coil of copper tubing with an outside diameter of 3/8" (9.5 mm) or greater. The appropriate plastic tubing may be substituted.
- A 3/8" flare fitting.

USING A WATER FILTER CARTRIDGE:

The filter cartridge supplied with this merchandiser will do the following:

- Filter many particles suspended in the water.
- Introduce a good grade of sequesterant into the water to inhibit the formation of lime scale when hard water is heated.

The filter cartridge is effective to the following limits:

- 7 oz. cup - 26,000 vends
- 8.25 oz. cup - 22,000 vends
- 9 oz. cup - 20,000 vends

Hot Drink Module Setup, Operation and Service Manual

How to Turn the Merchandiser ON and OFF

POWER PANEL

- Power to the merchandiser is controlled by the main power switch, located on the power panel.
- The power panel is on the right side of the merchandiser, behind the monetary door.

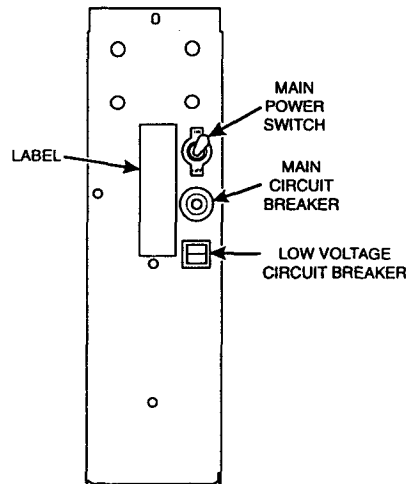

POWER CONTROL PANEL
U.S./CANADA

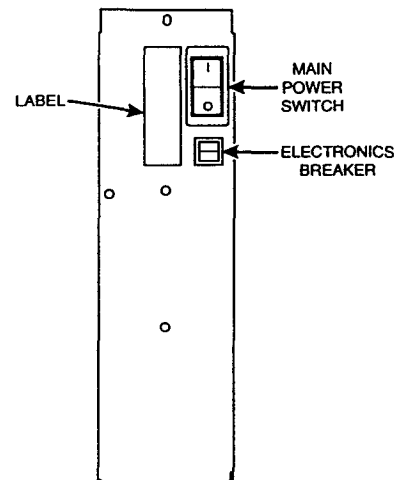

POWER CONTROL PANEL
INTERNATIONAL

WARNING

Lethal voltages are present. Unplug the merchandiser whenever you do one of the following tasks:

- Change a fuse
- Change the fluorescent lamp
- Change the lamp starter
- Connect or disconnect a harness (except a motor harness when a tray has been removed)

Failure to do so may result in personal injury.

Initial Setup

1. Remove the Canisters

1. The retaining clip wraps around the canister nozzle and is used to secure the canister to the shelf. Unlatch the retaining clip.
2. Lift up on the lower front edge of the canister base and lift the assembly clear of the shelf.

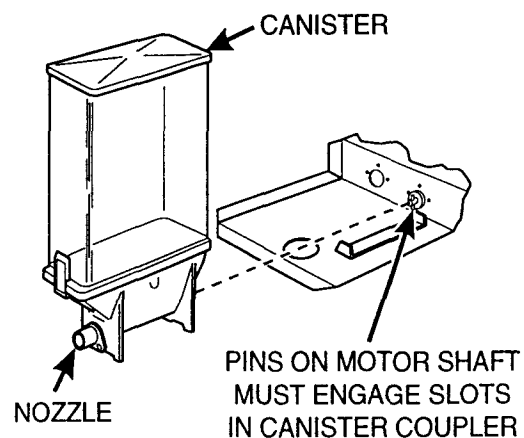

Hot Drink Module Setup, Operation and Service Manual

2. Remove Two Trays

- You will need to remove the second and third trays from the top. This will make it much easier to install the water filter cartridge. Proceed as follows:

1. Push back on the tray slightly with your palms. This releases the tray latches.
2. Push down on the tray latches with your thumbs.

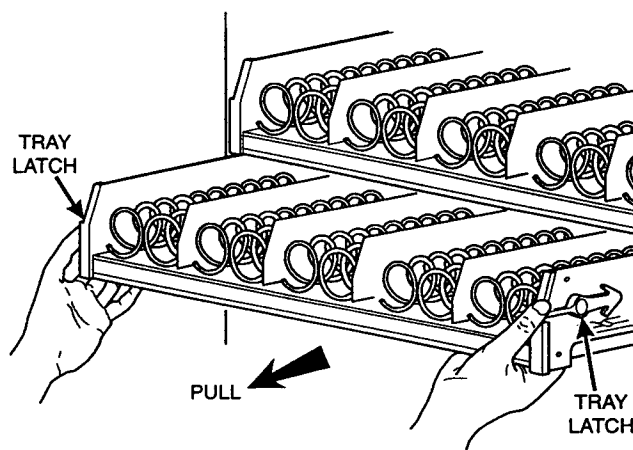

3. Pull the tray forward until you hear and feel the rear tray rollers drop into a cut-out in the top of the guide rail.

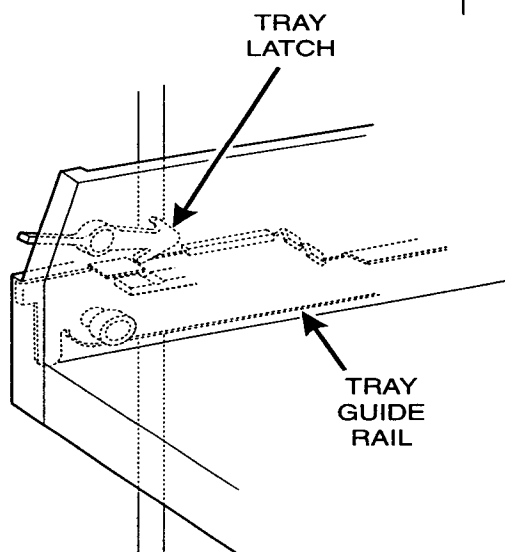

4. Unplug the tray wiring harness from the PC board mounted on the tray guide rail JUST ABOVE the tray you are removing.

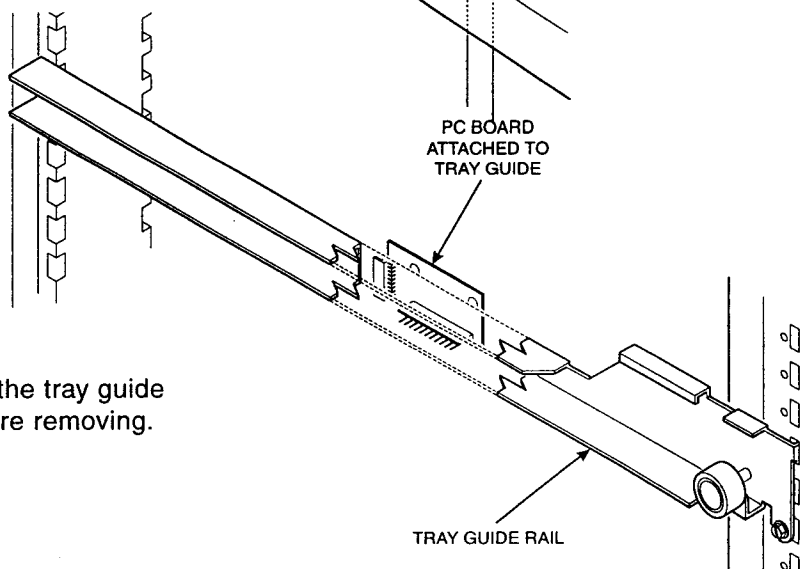

Hot Drink Module Setup, Operation and Service Manual

2. Remove Two Trays (continued)

5. Lift up on the tray and slide it toward the back. No more than an inch should be needed.

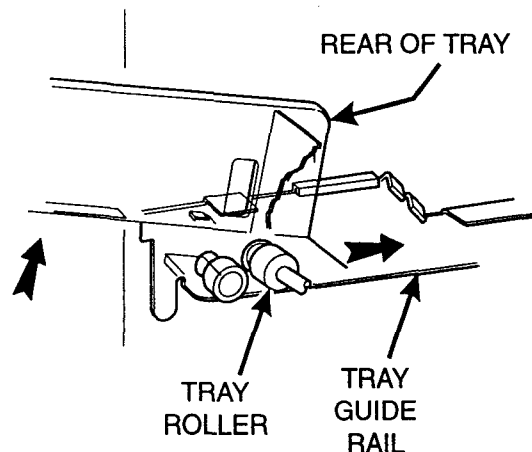
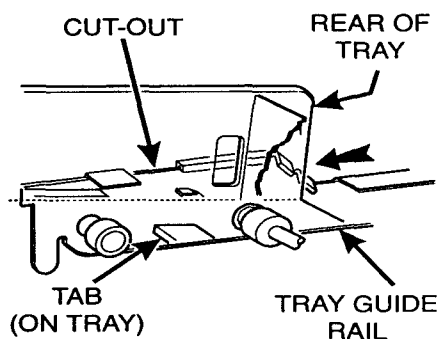

6. The tab near the back of the tray should align with the cut-out in the top of the tray guide rail as shown.
7. Lift the tray clear of the tray guide rail and out of the merchandiser.

3. Install the Water Filter Cartridge

1. Make sure the main power switch is in the **OFF** position.
2. See the **Interior View** for the location of the water filter. Flip the lock lever **UP** to the OFF position (view A).
3. As viewed from above, rotate the locking collar clockwise about 60° until it drops to the filter receiving position.
4. Align the raised rib near the top of the cartridge with the ribless portion of the locking collar.
5. Push the cartridge up into the filter head (view B).
6. As viewed from above, rotate the cartridge clockwise until the lock lever engages the locking collar (view C).
7. Push the lock lever **DOWN** to the ON position (view E).

NOTES

The water filter assembly cannot be operated without a properly installed water filter cartridge.

The valve handle on the water filter head is used to open and close the water inlet to the merchandiser.

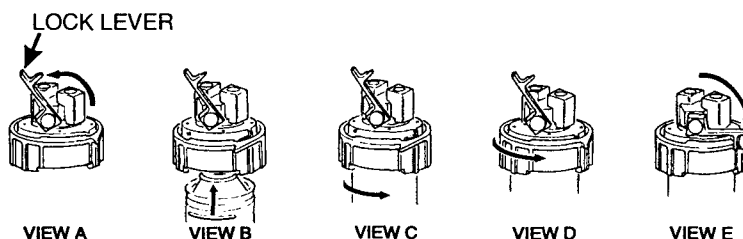

Hot Drink Module Setup, Operation and Service Manual

4. Install the Water Inlet Elbow

- A $\frac{3}{8}$ " flare x $\frac{3}{8}$ " NPTF elbow fitting is included in the same plastic bag that contained this manual.
1. Apply one turn of teflon tape or a thin coating of teflon paste to the threads, if they are not already coated.
 2. Turn the pipe thread end of the elbow into the inlet coupling mounted in back wall of the cabinet.

CAUTION

Do not overtighten the elbow. Doing so could cause the weld between the coupling and the cabinet to break.

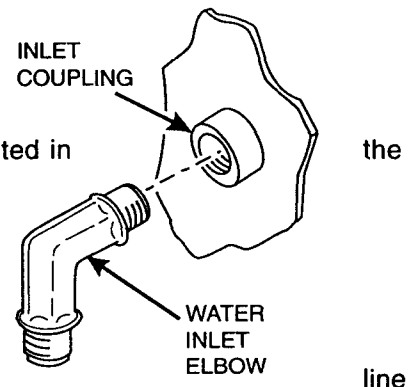

3. Before connecting your water line to the merchandiser, flush the line as follows:
 - a. Place the free end of the water line in a large container.
 - b. Turn on the water at its source, and let at least five gallons of water flow through the line.
 - c. Turn off the water at its source.
4. Connect the water line to the water inlet elbow.
5. Turn on the water at its source and check for leaks.
6. Make sure the main power switch is **OFF**. Plug in the machine. Turn the main power switch to **ON**. Listen for the water tank to begin filling. Check for leaks from time to time while the tank is filling.

5. Adjust the Hot Drink Price Labels

1. Remove the cup turret assembly to access the price labels.
 - The upper price roll is for the coffee selection.
 - The lower price roll is for the hot chocolate selection.
2. Scroll the price roll down to decrease the price.
3. Scroll the price roll up to increase the price.
4. View the price from the front of the door. Verify that the price is correct and centered.

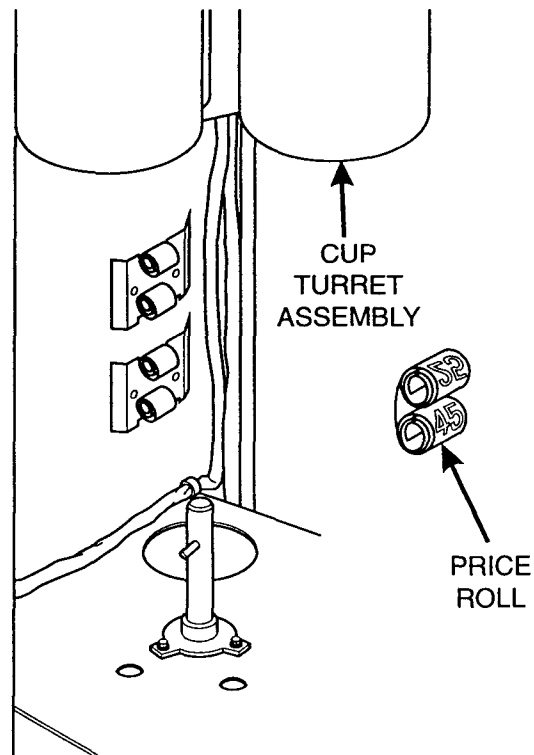

Hot Drink Module Setup, Operation and Service Manual

6. Adjust the Cup Mechanism

Your machine is factory set to use an 8-ounce cup. If you are going to use a different size cup, see the Programming Section for instructions on how to change cup sizes.

IMPORTANT

Two 8-ounce cups from different manufacturers can physically differ. It is important that you adjust the cup mechanism and cup deflector for the specific cup you are going to use, especially if you change cup sizes.

1. The large opening in the top of the cup mechanism is the drop ring opening. Place seven cups in the drop ring opening.
2. Observe the clearance between the cups and the cup cams. Compare with the three bottom views on the right.
3. If the clearance is correct, you are finished with this procedure. If not, go to the next step.
4. Adjust the cup ring as follows:
 - a. Loosen the adjustment arm screw as shown.
 - b. Move the adjustment arm until the correct clearance is achieved, and the cups rotate freely.
 - c. Hold the adjustment arm in place and tighten the adjustment arm screw.

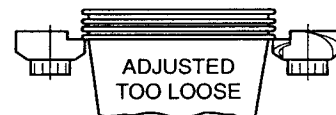
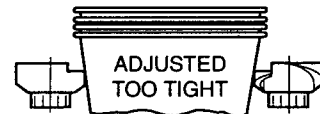
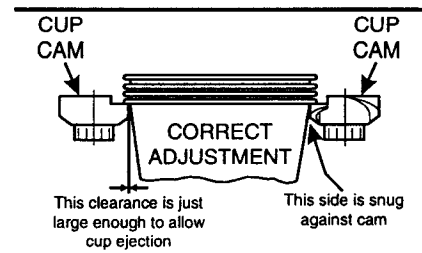
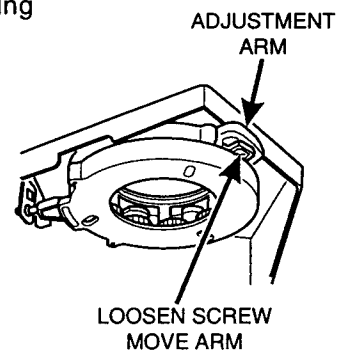

Hot Drink Module Setup, Operation and Service Manual

6. Adjust the Cup Mechanism (continued)

5. If you are using plastic cups, move the release ramp to the fast position as shown. If not, make sure the release ramp is in the slow or normal position as shown.
6. Remove the seven cups from the cup ring.
7. Close and open the cabinet door.
8. Look at the display. If it shows **NO CUPS**, you are finished. Otherwise, perform the sold-out and turret rotate switch adjustment procedure, below.

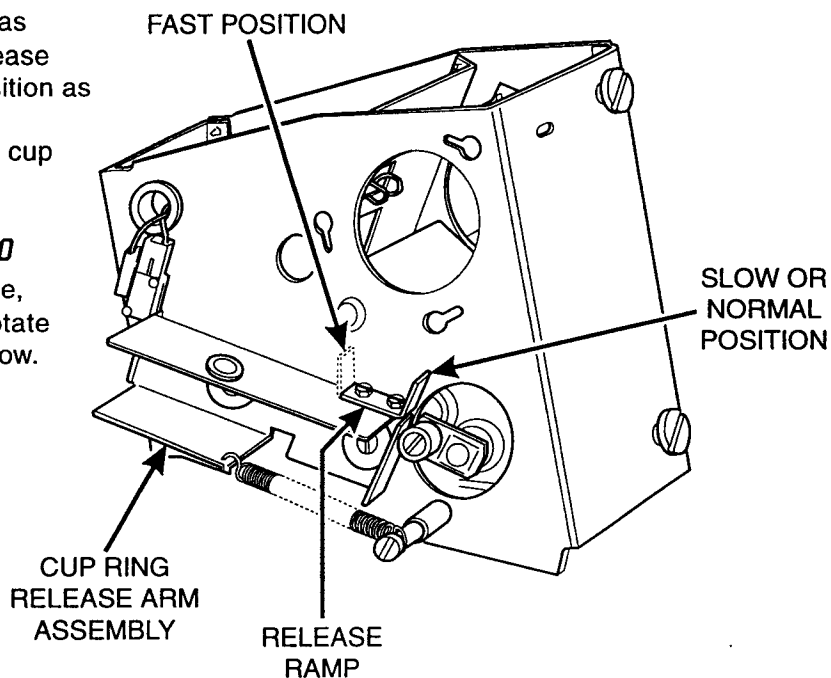

ADJUST THE SOLD-OUT AND TURRET ROTATE SWITCHES:

1. Loosen the front nut securing the switches to the cup dispenser.
2. Pivot the switches away from the cup drop ring opening.
3. Install a stack of seven or more cups in the drop ring.
4. Pivot the switches toward the cups until the switch actuating levers touch the cups. You should hear a "clicking" sound made by the two switches.
5. Tighten the nut that secures the switches to the cup dispenser.
6. Remove the cups from the cup ring.
7. Close and open the cabinet door.
8. Look at the display. If it shows **NO CUPS**, you are finished. Otherwise, return to step 1.

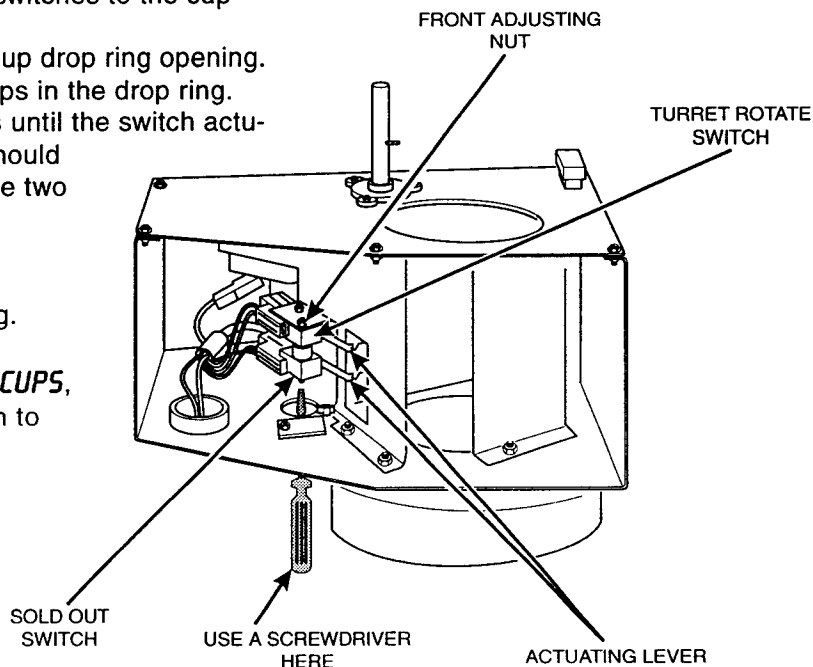

Hot Drink Module Setup, Operation and Service Manual

7. Load the Cup Mechanism

CAUTION

Use only cups which have been designed for use in a hot beverage vending machine. Handle all cups with care, and avoid touching the rims.

1. Replace the turret in the machine.
2. Remove the turret cover.
3. Inspect a stack of cups. Do the following:
 - a. Discard any irregular cups,
 - b. Discard any crushed or damaged cups,
 - c. Loosen any cups stuck together
4. Place one hand under the cup mechanism to catch the cups as you drop them into each tube.
5. Replace the turret cover after all of the tubes have been loaded.

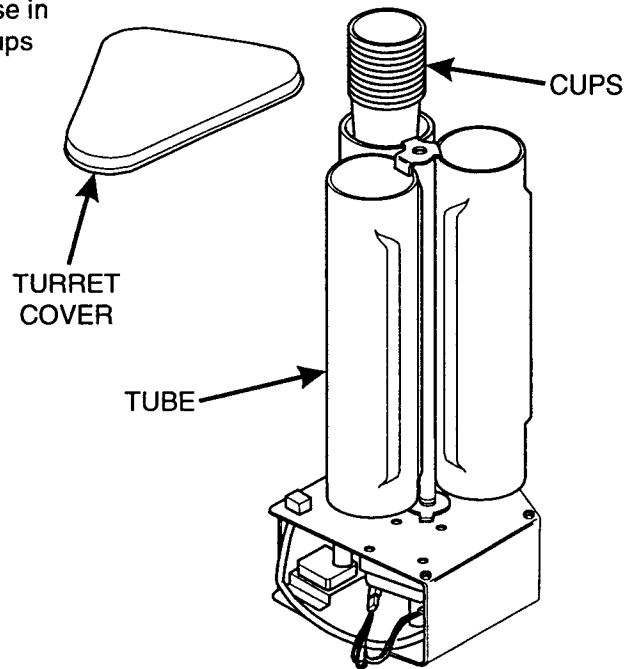

8. Adjust the Cup Deflector

The cup deflector is adjustable for different cup sizes.

1. Into the cup compartment, place one of the same kind of cups you loaded in the cup turret.
2. Loosen the thumb screw on the top of the cup deflector.
3. The distance between the cup and the deflector should be about $\frac{1}{4}$ " (6mm).
4. Move the pivot bar to the left to decrease the distance between the cup and the deflector.
5. Move the pivot bar to the right to increase the distance between the cup and the deflector.
6. Hold the pivot bar and deflector in place and tighten the thumb screw.

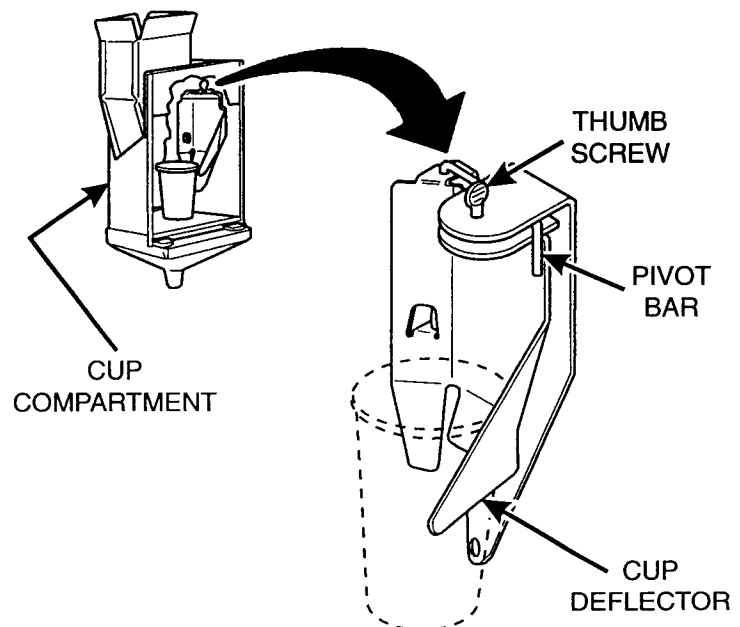

Hot Drink Module Setup, Operation and Service Manual

9. Load the Dry Ingredient Canisters

INGREDIENT SPECIFICATIONS

PRODUCT	CANISTER CAPACITY	SPECIFICATION	SPECIAL COMMENTS
Chocolate	5 lb. (2.3 kg)	All-in-one commercial chocolate mix	DO NOT tap the canister to settle the contents. (Doing so can pack the auger, and the product will not dispense.)
Whitener	3 lb. (1.4 kg)	Non-caking powder type	
Sugar	5 lb. (2.3 kg)	Regular, fine, granulated table sugar	Cane sugar is the recommended alternative.
Tea	5 lb. (2.3 kg)	Bulk leaf tea	
Fresh brew coffee or decaf	4.5 lb (2.1 kg)	Single cup, fine grind, vending machine coffee or decaf is recommended.	Soft water problems may require the use of a coarse grind.
Freeze dry coffee or decaf	3 lb. (1.4 kg)	Instantly soluble type	

CANISTER ASSIGNMENTS:

CANISTER 3 AND 4 INGREDIENT OPTIONS:

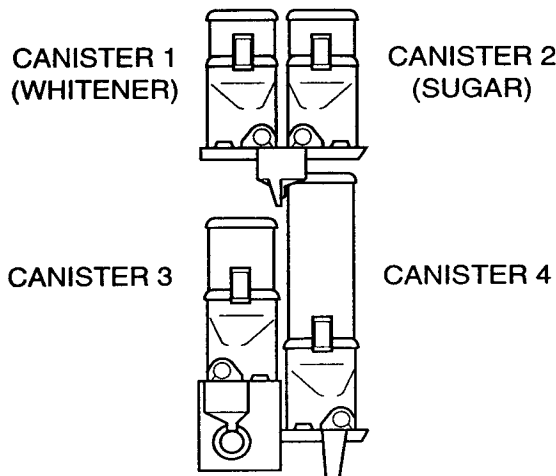

PRODUCT MIX	CANISTER	
	3 NON-BREWED	4 BREWED or FREEZE DRY
FRESH BREW	Chocolate *	Coffee, decaf, or tea
FB/SHORT	Chocolate *	Coffee or decaf
FB/SHORT /CAPP.	Chocolate **	Coffee or decaf
FREEZE DRY	Chocolate *	Coffee, decaf, or tea
FD/SHORT	Chocolate *	Coffee or decaf
FD/SHORT /CAPP.	Chocolate **	Coffee or decaf

* Chocolate is optional.
 ** Chocolate must be present to make a Cappuccino drink.

Hot Drink Module Setup, Operation and Service Manual

10. Connect the Water Heater Harness

WARNING

Lethal voltages are present. Be sure to turn the machine power **OFF** before completing the following procedure. Failure to do so may result in personal injury.

1. Wait until the water tank is full (the water will stop running).
2. Turn the machine power **OFF**.
3. Locate the safety thermostat on the water tank overflow tube.
4. Connect the safety thermostat to the heater harness.
5. Turn machine power **ON**.

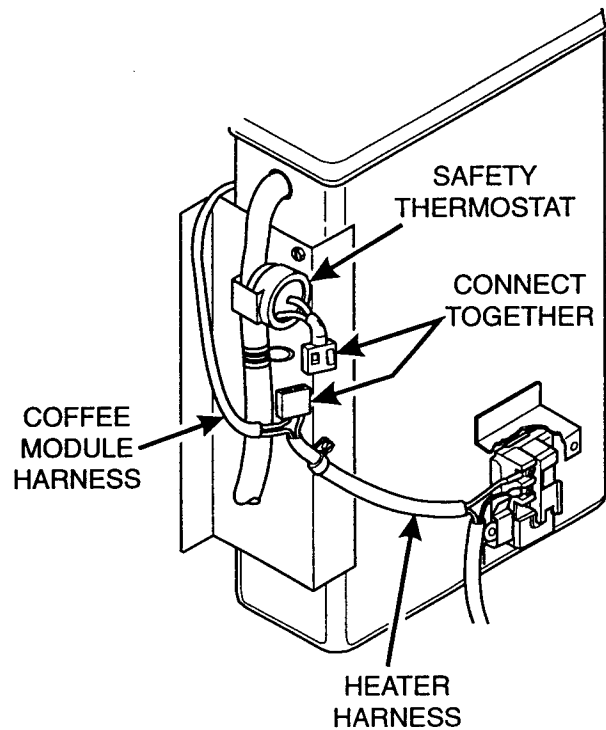

Hot Drink Module Setup, Operation and Service Manual

11. Replace the Two Trays

- Study this procedure before you install a tray for the first time; while you are holding the tray you will not be able to see this area. Proceed as follows:

1. Insert the tray so that the tray rollers pass over the tray guide rollers.

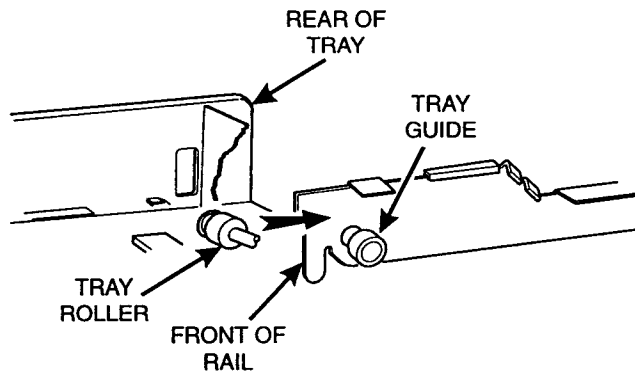

5. Hold the tray up while pushing it toward the rear. Stop when the tab on the tray aligns with the opening in the tray guide.

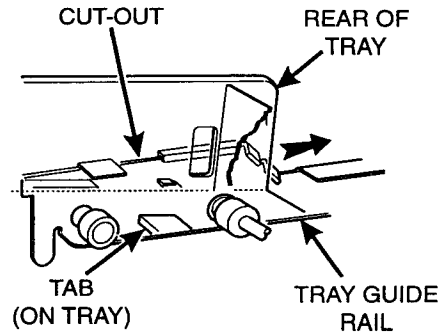

2. Bring the tray roller to rest on the tray guide.

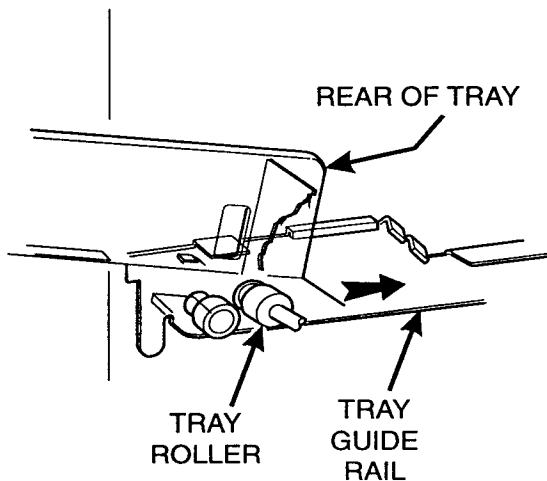

6. Lower the tray until it rests on the tray guide roller. Push the tray in all the way.

7. The tray latch will fall into the locking position.

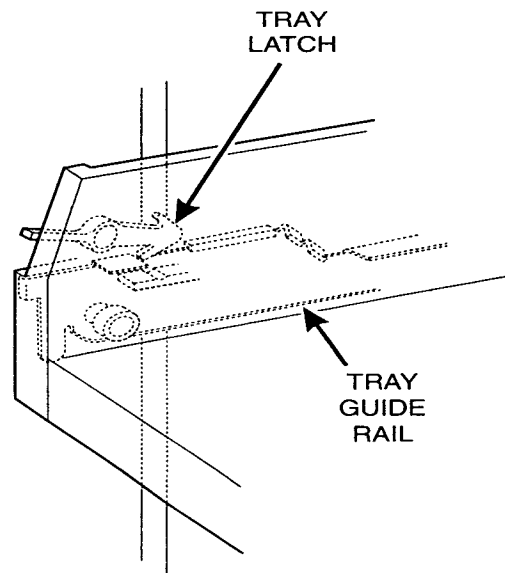

3. Tilt the tray upward.

4. Connect the tray wiring harness to the PC board mounted to the guide rail JUST ABOVE the tray you are installing.

Hot Drink Module Setup, Operation and Service Manual

12. Replace the Canisters

1. Be sure the pin in the dispenser motor shaft seats properly in the auger coupling as shown.
2. Place the wire retaining clip over the canister nozzle.
3. Be sure the canisters are securely resting on the shelves.

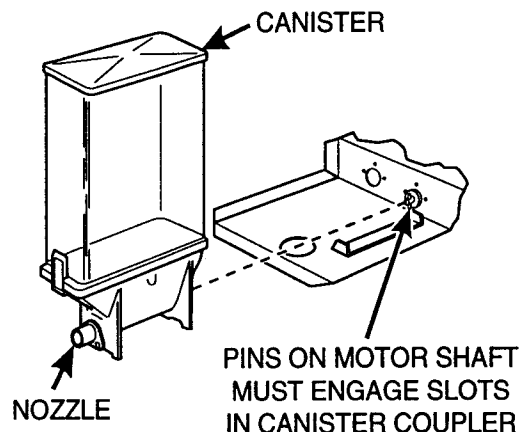

The drink recipes used by your machine are factory set. However, you can change these recipes to suit your individual taste. See the Programming Section in the Main Setup Guide for instructions on how to do this.

Setup is complete. The remainder of this booklet shows you how to load product, adjust water and product throw times, how to clean and sanitize your merchandiser, and how to remove and replace selected assemblies.

NOW WHAT?

There are still some things you need to do to complete setting up your merchandiser. Return to the same location in the *Main Setup Guide* that sent you to this booklet.

Hot Drink Module Setup, Operation and Service Manual

Where to Find Maintenance Procedures

PROCEDURE TITLE	PAGE
Air Pressure Adjustment	19
Beverage Discharge Nozzle Sanitizing	28
Brewer Barrel and Manifold Disassembly	24
Brewer Barrel and Manifold Reassembly	25
Brewer Barrel and Manifold Replacement	25
Brewer Basket Removal	24
Brewer Basket Replacement	24
Brewer Basket Screen Removal	24
Brewer Basket Screen and Brewer Barrel Screen Replacement	25
Brewer Components - Identification	23
Brewer Funnel Removal	25
Brewer Funnel Replacement	25
Brewer Mechanism Cleaning	26
Brewer Timing Adjustment	27
Canister Installation	13
Canister Loading	10
Canister Removal	3
Canister Sanitizing	30
Chocolate Funnel and Impeller Housing Sanitizing	31
Cleaning the Brewer Basket Screen and Brewer Barrel Screen	25
Cup Deflector - Adjust	9
Cup Delivery Compartment Removal and Replacement	28
Cup Delivery Compartment Sanitizing	28
Cup Mechanism - Adjustment	7
Cup Mechanism - Loading	9
Dry Ingredient Air Fluffing	30
Dry Ingredient Shelf Cleaning	30
Grounds Pail Cleaning	29
Measuring and Adjusting Dry Ingredients	17
Setting Brewed Selection Throw	17
Setting Hot Chocolate, Sugar, and Whitener Throw	17
Table C: Suggested Ingredient Times	18
Table D: Recommended Ingredient Weights	18
Measuring and Setting Water Temperature	29
Mixing Bowl Sanitizing	30
Overall Cleaning	21
Price Roll Adjustment	6
Removing the Brewer Barrel and Manifold	24
Sanitation	22
Sugar and Whitener Mixing Bowl Inspection	30
Tray Installation	11
Tray Removal	4
Vent Blower Filter Removal and Replacement	28
Waste Pail Sanitizing	29
Water Filter Cartridge Replacement	20
Water Filter Cartridge Service Limits	29
Water Filter Cartridge Removal	20
Water Measurement and Adjustment	15
Collecting Water Throws	16
Adjusting the Water Valves	16
Table A: Suggested Water Times	16
Table B: Suggested Water Volume	16

Hot Drink Module Setup, Operation and Service Manual

Water Measurement and Adjustment

SETTING WATER TIME IN A NEW MERCHANDISER OR WHEN AN OLD MERCHANDISER HAS A NEW VALVE:

1. Set the cup size option to 7 oz. See the *Programming Section* of your *Main Setup Manual* for the correct procedure.
2. Locate the correct time for the chosen product and cup size. See table A, *Suggested Water Times*.
3. Set the water time for this product. See the *Programming Section* of your *Main Setup Manual* for the correct procedure, and use the time for a 7 oz. cup.
4. Prepare to collect the water throw. See **COLLECTING WATER THROWS FOR A BREWED SELECTION** or **COLLECTING WATER THROWS FOR THE HOT CHOCOLATE OR HOT WATER SELECTIONS**, as appropriate.

WARNING

The water in the water tank is very hot. Use care when collecting water throws.

5. With the water time shown in the display, press (J). Water will be dispensed.
6. Measure the volume of the collected water. Compare with the values shown in Table B, *Recommended Water Volume*.
7. Adjust the valve as needed to increase or decrease water flow. See **ADJUSTING THE WATER VALVES**.
8. Repeat steps 4 through 7 until the correct volume of water is dispensed.
9. If a larger cup size is to be vended, increase the water time to the value listed in Table A.
10. Measure and compare the collected water volume with the value in Table B.
11. Adjust the time as needed to increase or decrease the water flow.
12. Reconnect the water supply tube to the brew barrel, if removed earlier.

SETTING WATER TIME AT ANY OTHER TIME:

1. Locate the correct time for the chosen product and cup size. See Table B, *Recommended Water Volume*.
2. Set the water time for this product. See the *Programming Section* of your *Main Setup Manual* for the correct procedure.
3. Prepare to collect the water throw. See **COLLECTING WATER THROWS FOR A BREWED SELECTION**, or **COLLECTING WATER THROWS FOR THE HOT CHOCOLATE OR HOT WATER SELECTIONS**, as appropriate.

WARNING

The water in the water tank is very hot. Use care when collecting water throws.

4. With the water time shown in the display, press (J). Water will be dispensed.
5. Measure the volume of the collected water. Compare with the values shown in Table B.
6. Adjust the time as needed to increase or decrease the water flow.
7. Repeat steps 3 through 6 until the correct volume of water is dispensed.
8. Reconnect the water supply tube to the brew barrel, if removed earlier.

Hot Drink Module Setup, Operation and Service Manual

Water Measurement and Adjustment (continued)

COLLECTING WATER THROWS FOR A BREWED SELECTION:

WARNING

The water in the water tank is very hot. Use care when collecting water throws.

1. Remove the water supply tube from the brew barrel manifold.
2. Insert the disconnected water tube in a clean cup and hold as shown.

COLLECTING WATER THROWS FOR THE HOT CHOCOLATE OR HOT WATER SELECTIONS:

1. Place a clean cup in the cup station to collect the water.

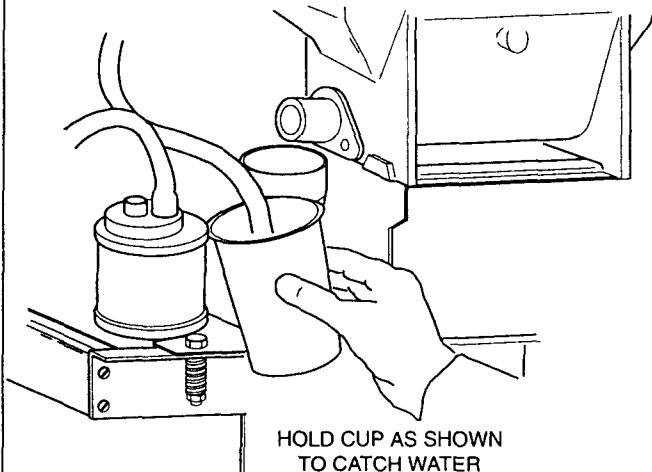

ADJUSTING THE WATER VALVES:

WARNING

The water in the water tank is very hot. Use care when collecting water throws.

1. Turn the water valve adjusting screw (as shown) clockwise to decrease water flow.
2. Turn the water valve adjusting screw (as shown) counterclockwise to increase water flow.

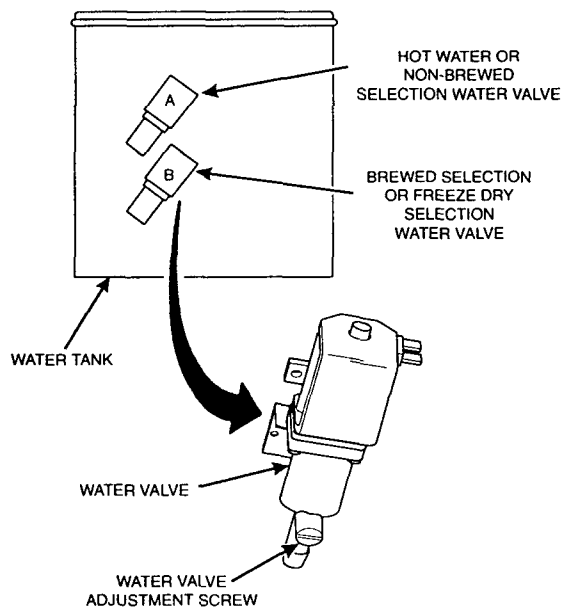

TABLE A: SUGGESTED WATER TIMES

SELECTION	CUP SIZE			
	5 oz	7 oz	8.25 oz	9 oz
Fresh brew	4.30 sec	5.00 sec	5.90 sec	6.40 sec
Freeze dry	6.75 sec	8.00 sec	9.45 sec	10.25 sec
Hot chocolate	8.65 sec	10.2 sec	12.0 sec	13.0 sec
Hot water	6.75 sec	8.00 sec	9.45 sec	10.25 sec
Instant Tea	6.75 sec	8.00 sec	9.45 sec	10.25 sec
Fresh Brew Tea	4.30 sec	5.00 sec	5.90 sec	6.40 sec

Local conditions may require different times in order to dispense the correct volume of water.

TABLE B: RECOMMENDED WATER VOLUME

SELECTION	CUP SIZE			
	5 oz	7 oz	8.25 oz	9 oz
Fresh brew	130 ml	190 ml	220 ml	240 ml
Freeze dry	120 ml	170 ml	200 ml	210 ml
Hot chocolate	100 ml	140 ml	170 ml	180 ml
Hot water	100 ml	140 ml	170 ml	180 ml
Instant Tea	120 ml	170 ml	200 ml	210 ml
Fresh Brew Tea	130 ml	190 ml	220 ml	240 ml

Hot Drink Module Setup, Operation and Service Manual

Measuring and Adjusting Dry Ingredients

SETTING BREWED SELECTION THROW:

WARNING

Keep your hands away from the moving parts of the brewer while it is cycling.

1. Locate the correct time for the chosen product and cup size. See Table C: **Suggested Ingredient Times**.
2. Set a new time for this ingredient or review the current time. See the *Programming Section* of your *Main Setup Manual* for the correct procedure.
3. Hold a clean, empty cup under the canister discharge funnel as shown.
4. With the ingredient time shown in the display, press **J**. The dry ingredient will be dispensed.
5. Weigh the collected ingredient. Compare with the value given in Table B: **Recommended Ingredient Weights**.
6. Adjust the time as needed to increase or decrease the amount of ingredient dispensed.
7. Repeat steps 3 through 6 until the correct amount of dry ingredient has been dispensed.

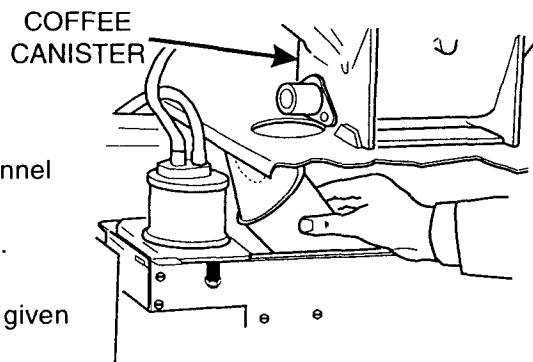

SETTING HOT CHOCOLATE, SUGAR, AND WHITENER THROW:

1. Locate the correct time for the chosen product and cup size. See Table C: **Suggested Ingredient Times**.
2. Remove the mixing bowl for the ingredient being measured.
3. Set a new time for this ingredient or review the current time. See the *Programming Section* of your *Main Setup Manual* for the correct procedure.
4. Hold a clean, empty cup under the dispensing spout for the chosen ingredient. See the figure at the right for hot chocolate, and the figure on the next page for sugar or whitener.
5. With the ingredient time shown in the display, press **J**. The dry ingredient will be dispensed.
6. Weigh the collected ingredient. Compare with the value given in Table D: **Recommended Ingredient Weights**.
7. Adjust the time as needed to increase or decrease the amount of ingredient dispensed.
8. Repeat steps 4 through 7 until the correct amount of dry ingredient has been dispensed.

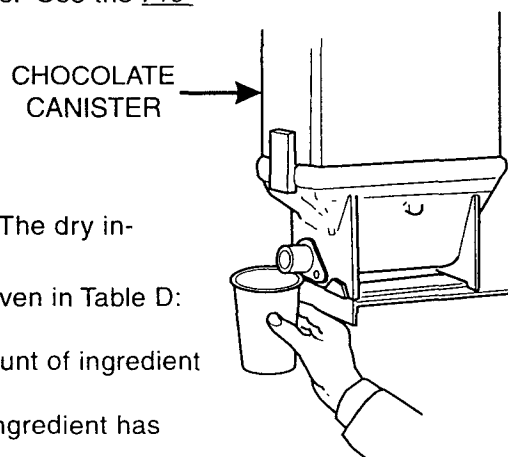

Hot Drink Module Setup, Operation and Service Manual

Measuring and Adjusting Dry Ingredients (continued)

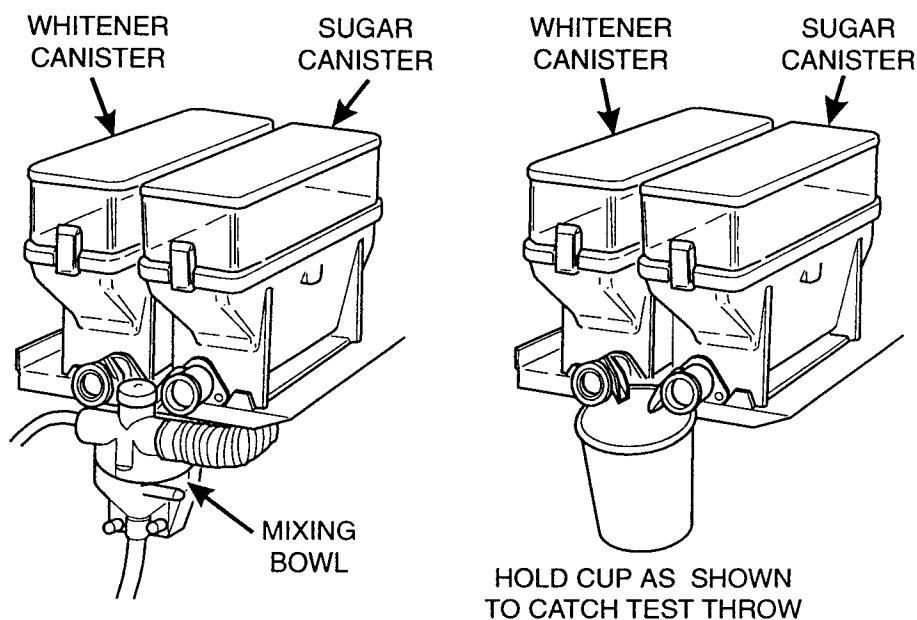

TABLE C: SUGGESTED INGREDIENT TIMES

TABLE D: RECOMMENDED INGREDIENT WEIGHTS

SELECTION		CUP SIZE			
		5 oz	7 oz	8.25 oz	9 oz
Fresh Brew	Regular	2.60 sec*	2.70 sec*	2.90 sec*	3.40 sec*
	Strong	2.60 sec**	2.70 sec**	2.90 sec**	3.40 sec**
Freeze Dry	Regular	1.00 sec	1.10 sec	1.50 sec	1.90 sec
	Strong	1.25 sec	1.40 sec	1.80 sec	2.20 sec
Hot chocolate		2.60 sec	2.90 sec	3.40 sec	3.80 sec
Tea		<i>Find correct time by testing</i>			
Sugar		1.70 sec	1.60 sec	1.80 sec	2.10 sec
Total sugar extra		2.00 sec	2.20 sec	2.40 sec	2.70 sec
Whitener		0.35 sec	1.40 sec	0.55 sec	0.65 sec
Total whitener extra		0.50 sec	0.55 sec	0.65 sec	0.80 sec

* Regular fresh brew uses a steep time of 3 seconds.
 ** Strong fresh brew uses a steep time of 5 seconds.

SELECTION		CUP SIZE		
		7 oz	8.25 oz	9 oz
Fresh brew		8 g.	9 g.	10 g.
Freeze dry	Regular	1.0 g.	1.5 g.	2.0 g.
	Strong	1.2 g.	1.7 g.	2.3 g.
Hot chocolate		24 g.	28 g.	31 g.
Tea		<i>Find correct weight by testing.</i>		
Sugar		6 g.	7 g.	8 g.
Total sugar extra		8 g.	9 g.	10 g.
Whitener		1.5 g.	2 g.	2.5 g.
Total whitener ex.		2 g.	2.5 g.	3 g.

NOTE

In the end, the amount of dry ingredients you use is a matter of taste. The times in the tables are only meant to be used as a starting point. If the drink does not taste right to you, try a range of times until the taste is more to your liking. In addition to taste, the amount of dry ingredients is also influenced by local water conditions and the brand of ingredient you use.

Hot Drink Module Setup, Operation and Service Manual

Air Pressure Adjustment

The air pressure gauge is located below the chocolate canister. It is mounted on the front of the chocolate shelf as shown.

The air pressure regulator assembly is located on the other side of the shelf panel in line with the gauge as shown.

- Adjust the air pressure regulator while a brewed selection is being vended.
- While the air compressor is running, the pressure will register on the pressure gauge.
- Air pressure must be sufficient to force the brew past the filter screen, out of the brewer barrel, and up to the mixing bowl.
- Once the brew reaches the mixing bowl, it must start a swirling action in the bowl. The swirling action mixes the sugar and whitener with the brew.
- Ideally, you should set the air pressure to the lowest workable pressure; between 4 and 8 psi (0.28 and 0.55 bar). If the pressure is too high, the brew will overshoot the mixing bowl.

1. Turn the knurled knob on the regulator clockwise to increase pressure. Turn it counterclockwise to decrease the pressure.

NOTE

Generally, decaf requires more pressure than regular coffee.

2. Run a series of test vends to determine the best setting for your location and machine.

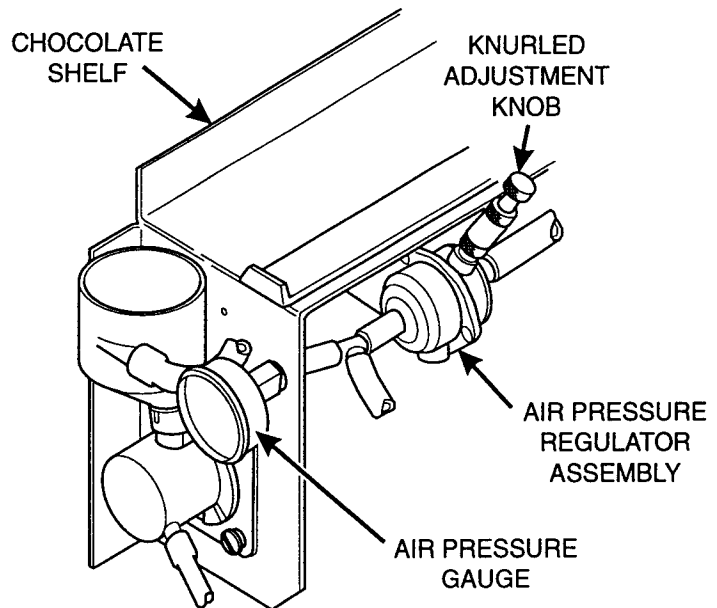

Hot Drink Module Setup, Operation and Service Manual

Air Pressure Adjustment

The air pressure gauge is located below the chocolate canister. It is mounted on the front of the chocolate shelf as shown.

The air pressure regulator assembly is located on the other side of the shelf panel in line with the gauge as shown.

- Adjust the air pressure regulator while a brewed selection is being vended.
- While the air compressor is running, the pressure will register on the pressure gauge.
- Air pressure must be sufficient to force the brew past the filter screen, out of the brewer barrel, and up to the mixing bowl.
- Once the brew reaches the mixing bowl, it must start a swirling action in the bowl. The swirling action mixes the sugar and whitener with the brew.
- Ideally, you should set the air pressure to the lowest workable pressure; between 4 and 8 psi (0.28 and 0.55 bar). If the pressure is too high, the brew will overshoot the mixing bowl.

1. Turn the knurled knob on the regulator clockwise to increase pressure. Turn it counterclockwise to decrease the pressure.

NOTE

Generally, decaf requires more pressure than regular coffee.

2. Run a series of test vends to determine the best setting for your location and machine.

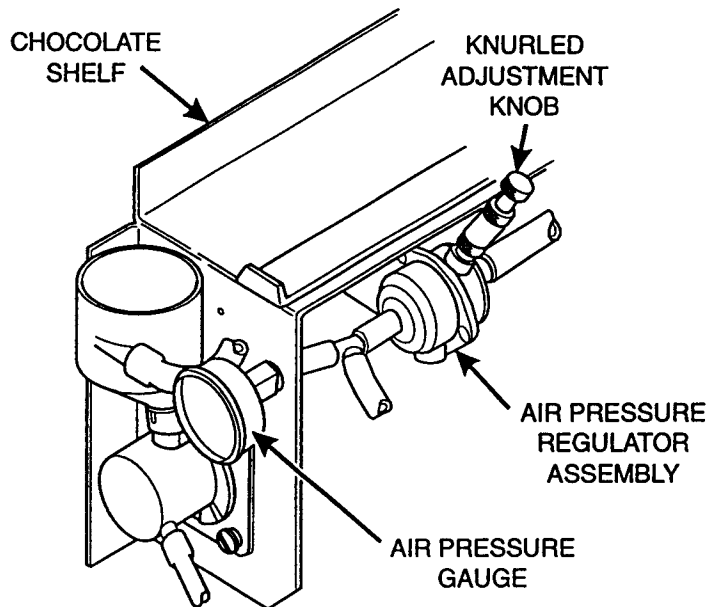

Hot Drink Module Setup, Operation and Service Manual

Water Filter Cartridge Removal

1. Close the water supply line shut-off valve.
2. Turn the main power switch to the OFF position.
3. Flip the lock lever up (view A).
4. As viewed from above, rotate the cartridge clockwise about 60°. The locking collar will turn with the cartridge.
5. When the locking collar drops about $\frac{3}{8}$ ", rotate the cartridge another 45° or so.
6. Pull the cartridge down to separate it from the head assembly.

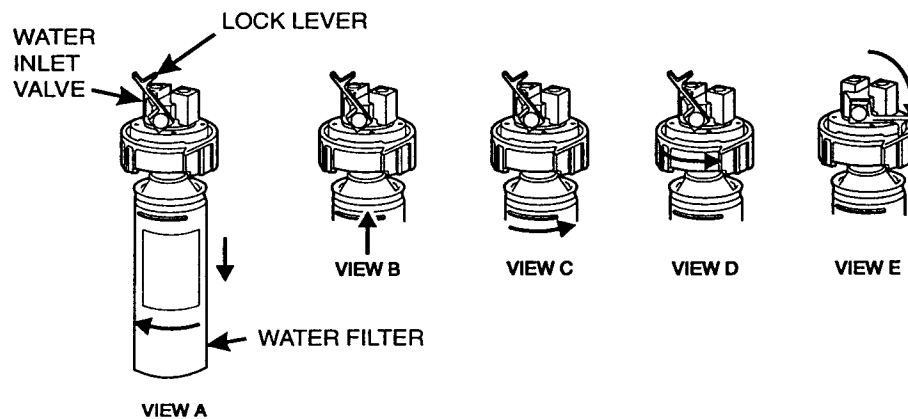

Water Filter Cartridge Replacement

1. Make sure the main power switch is in the **OFF** position.
2. Flip the lock lever **UP** (view A).
3. As viewed from above, rotate the locking collar clockwise about 60° until it drops to the filter receiving position.
4. Align the raised rib near the top of the cartridge with the ribless portion of the locking collar.
5. Push the cartridge up into the filter head (view B).
6. As viewed from above, rotate the cartridge clockwise until the lock lever engages the locking collar (view C).
7. Push the lock lever **DOWN** (view D).

NOTES

DO NOT flush the water filter cartridge.

The water filter assembly cannot be operated without a properly installed water filter cartridge.

The valve handle on the water filter head is used to open and close the water inlet to the merchandiser.

Hot Drink Module Setup, Operation and Service Manual

Overall Cleaning

1. Inspect the merchandiser both inside and out. Be sure to check corners and less visible parts of the merchandiser.
2. Clean where needed.
3. Allow the inside of the cabinet to dry thoroughly before closing the door.
4. Glasco recommends using the following supplies:
 - Use a commercial glass cleaner on the glass in the cabinet door.
 - Use a mild detergent and warm water on the cabinet, trays, spirals, gum and mint assembly, and other *non-electrical* components. Brewer cleaning is discussed later in this manual.

CAUTION

Clean the plastic components in this merchandiser with a mild detergent and warm water. Avoid using other cleaning agents because they may damage the material.

RECOMMENDED SERVICE

PROCEDURE	DAILY	WEEKLY	MONTHLY	QUARTERLY	SEMI-ANNUAL
Brewer barrel and basket	X				
Coffee funnel					X
In-tank water temperature	X				
Water filter service limit	X				
Water volume check				X	
Water tank liming inspection					X
Refill coin tubes	X				
Inspect and clean coin mech		X			
Inspect and clean bill validator		X			
Empty bill magazine	X				
Refill ingredient canisters	X				
Fluff dry ingredients		X			
Test vend products	X				
Inspect mixing bowls	X				
Check ingredient throw				X	
Refill cup tubes	X				
Inspect lamp bulbs	X				
Inspect exhaust filter		X			
Lubrication					X
Inspect springs					X
Inspect moving parts					X

NR = No reference given

Hot Drink Module Setup, Operation and Service Manual

Sanitation

RECOMMENDED SANITATION

PROCEDURE	DAILY	WEEKLY	MONTHLY	QUARTERLY	SEMI-ANNUAL
Clean brewer mechanism		X			
Wash brewer mechanism			X		
Clean ingredient shelf	X				
Sanitize canisters			X		
Rinse mixing bowls	X				
Sanitize mixing bowls		X			
Sanitize impeller funnel		X			
Sanitize dispenser nozzles		X			
Replace tubing					X See note 1
Sanitize cup compartment	X				
Clean the grounds pail	X				
Sanitize the waste pail	X				
Clean merchandiser overall	X				

Note 1: Replace the tubing only if needed. Use of the auto rinse feature extends the life of the tubing.

**THE MOST PROFITABLE MERCHANDISER
IS CLEAN AND WELL MAINTAINED**

Hot Drink Module Setup, Operation and Service Manual

Identification of Brewer Components

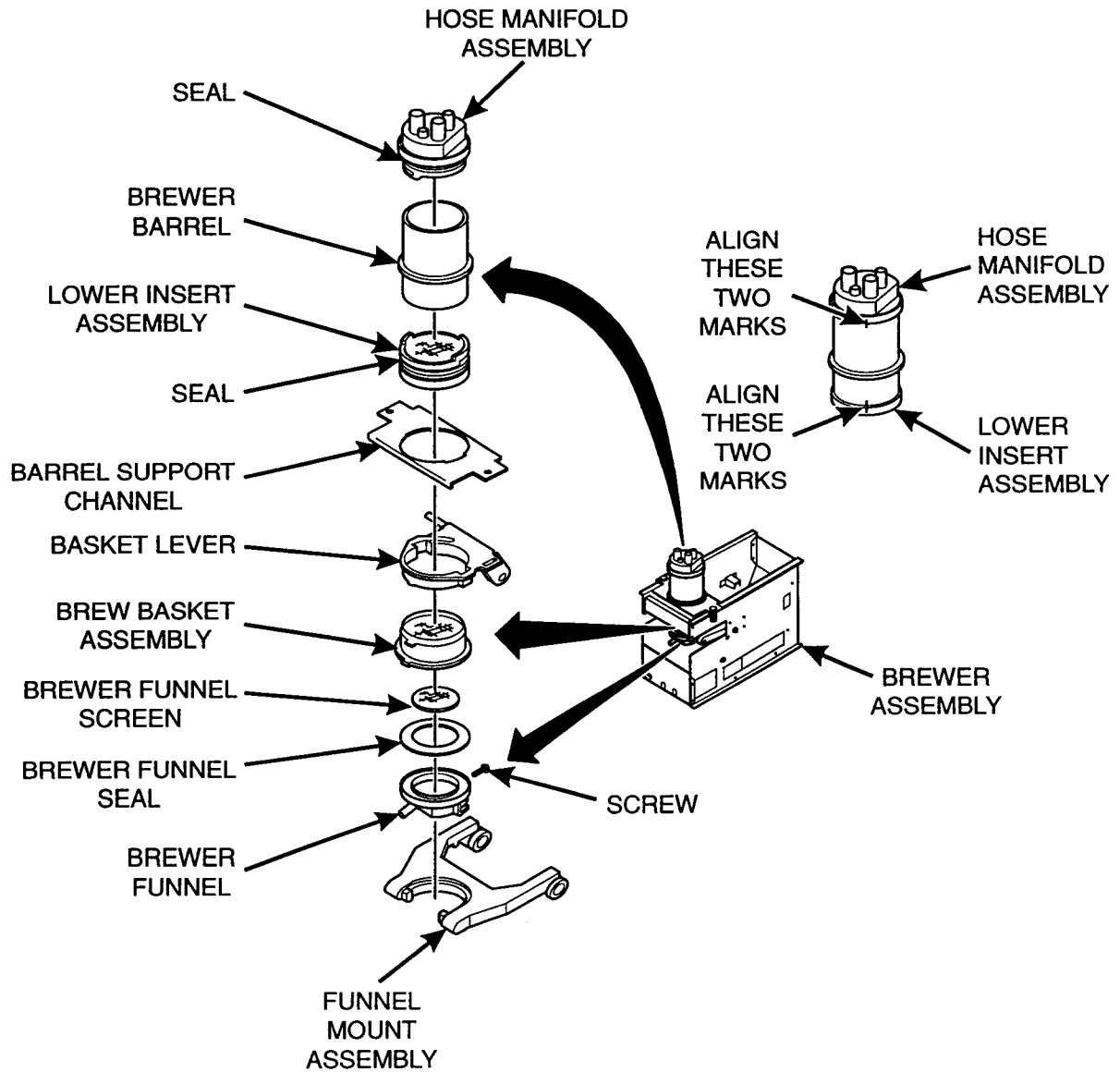

Hot Drink Module Setup, Operation and Service Manual

Removing the Brewer Barrel and Manifold

WARNING

Wear safety goggles or other eye protection whenever you remove the brewer mechanism cover.

1. Remove the brewer mechanism cover.
2. If the barrel and manifold are to be removed as an assembly, disconnect the tubes from the manifold.
3. Rotate the brewer barrel with the slots in the support channel.
4. Lift the brewer barrel and manifold assembly clear of the support channel.

Disassembling the Brewer Barrel and Manifold

1. As viewed from the bottom, rotate the brewer barrel $\frac{1}{4}$ turn clockwise and pull the lower insert assembly clear of the brewer barrel.
2. As viewed from the top, rotate the brewer barrel $\frac{1}{4}$ turn clockwise and pull the manifold clear of the brewer barrel.

Brewer Basket Removal

1. Rotate the basket $\frac{1}{4}$ turn clockwise to align the flanges of the basket with the slots in the basket lever.

Brewer Basket Replacement

1. Raise the basket lever and hold in position;
2. Align the flanges of the basket with the slots in the lever.
3. Insert the basket into the lever and rotate the basket counterclockwise. A spring clip in the basket lever should engage the lock tab in the basket.

Brewer Basket Screen Removal

CAUTION

Use care during this procedure, as the screen can be easily damaged if your screwdriver slips.

1. Using a small screwdriver, remove the screen retainer screen from the bottom side of the brewer basket as shown.
2. Remove the screen from the basket.

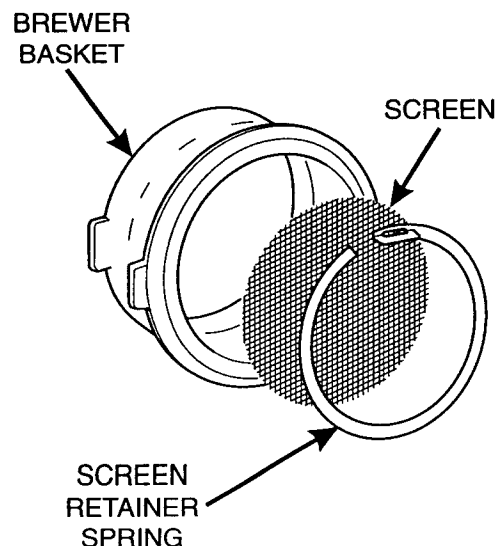

Hot Drink Module Setup, Operation and Service Manual

Cleaning the Brewer Basket Screen and Brewer Barrel Screen

1. Inspect the screens and replace them if damaged.
2. Prepare a solution of urn cleaner in a container.
3. Place the screens in the urn cleaner solution. Agitate the solution while brushing the screen with a soft bristle brush.
4. Rinse the screens thoroughly in hot water.

NOTE

You can save time by replacing these parts with similar parts that have already been cleaned in the shop.

Brewer Basket Screen and Brewer Barrel Screen Replacement

1. Return the brewer basket to the brewer barrel.
2. Return the brewer barrel screen to the brewer barrel.

NOTE

Use a 230 mesh screen in this merchandiser.

3. Press the screen firmly in place.
4. When replacing the brewer basket screen, insert the plain end of the retainer spring into the groove in the brewer basket.
5. Press the retainer spring until it seats in the groove. See the figure on the previous page.

Brewer Barrel and Manifold Reassembly

1. Insert the manifold into the top of the brewer barrel.
2. When viewed from the top, rotate the barrel counterclockwise until the registration marks are in line.
3. Insert the lower insert assembly into the brewer barrel.
4. As viewed from the bottom, rotate the barrel counterclockwise until the registration marks are in line.

Brewer Barrel and Manifold Replacement

1. Position the brewer barrel and manifold assembly so the flanges of the barrel are in line with the slots in the support channel.
2. Press down and rotate the barrel $\frac{1}{4}$ turn clockwise.
3. If any tubes were disconnected from the manifold, reconnect them.

Brewer Funnel Removal

1. Raise the funnel mount lever.
2. Pivot the front edge of the funnel assembly downward about 90°
3. Push down on the funnel to separate it from the lever pins.
4. If the funnel is to be removed from the merchandiser, disconnect the discharge tube from the funnel.

Brewer Funnel Replacement

1. Raise the funnel mount lever.
2. The dispensing port should be pointed downward and the top of the funnel should be facing left. While the funnel is in this position, slide it over the lever pins.
3. Pivot the funnel assembly upward and return the lever to the home position.
4. If the funnel was removed from the merchandiser, reconnect the discharge tube.

Hot Drink Module Setup, Operation and Service Manual

Brewer Mechanism Cleaning

REMOVING THE BREWER MECHANISM:

NOTE

Glasco recommends that the brewer mechanism be removed from the merchandiser for cleaning.

1. Remove the brewer barrel and manifold assembly. See **REMOVING THE BREWER BARREL AND MANIFOLD**.
2. Disconnect the discharge tube from the brewer funnel. See **BREWER FUNNEL REMOVAL**.
3. Remove the cup delivery compartment. See **CUP DELIVERY COMPARTMENT REMOVAL AND REPLACEMENT**.
4. Remove the cup delivery compartment mounting bracket.
5. Rotate the brewer mechanism stabilizing lever forward and up as shown. Place it in a horizontal position.
6. Lift the brewer mechanism off its mounting bracket.
7. Remove the brewer mechanism from the merchandiser.

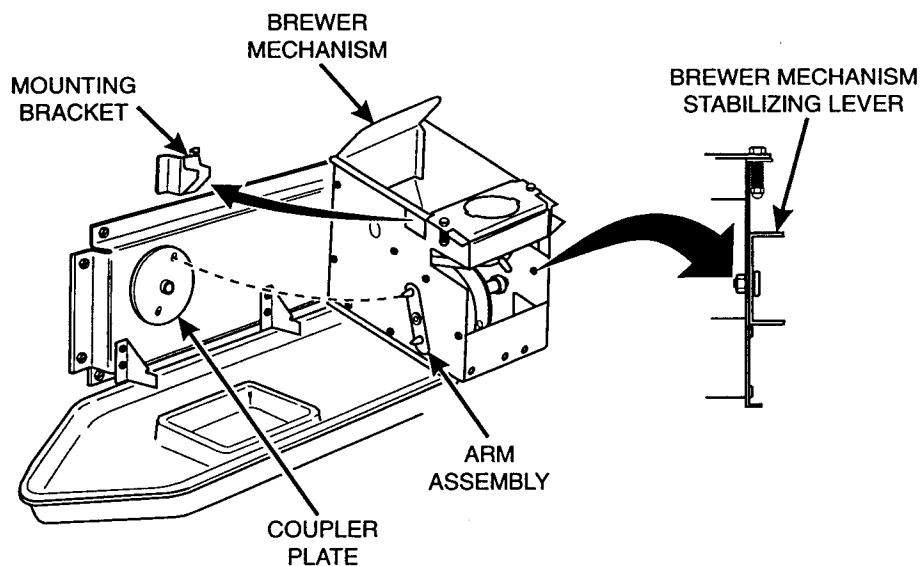

WASHING THE BREWER MECHANISM:

1. Wash the brewer mechanism with detergent and hot water.
2. Rinse the mechanism and allow it to dry thoroughly.

REPLACING THE BREWER MECHANISM:

1. Hang the brewer mechanism on its mounting bracket.
2. Be sure the arm assembly pins (at the rear of the brewer) line up with the holes in the coupler plate as shown.
3. Replace the cup delivery compartment mounting bracket, the cup delivery compartment, the brewer barrel and manifold assembly, and the brewer mechanism cover.
4. Reconnect all of the tubes that were disconnected.
5. Rotate the brewer mechanism stabilizing lever down and back into place.

Hot Drink Module Setup, Operation and Service Manual

Brewer Timing Adjustment

CHECK THE TIMING:

1. Remove the cup station.
2. Refer to the *Programming Section* of your *Main Setup Manual*: Cycle the brewer into the CLAMP position.
3. Look inside the brewer and observe the roller which rides on the funnel cam. There should be two marks on the funnel cam lobe on either side of the roller. These are the timing marks. If the roller is not between the marks, the timing needs to be adjusted.

ADJUST THE TIMING:

1. Loosen the knurled knob on the brewer drive assembly next to the coupler plate.
2. Move the knurled knob up or down slightly in its groove.
3. Tighten the knob.
4. Refer to the *Programming Section* of your *Main Setup Manual*: Cycle the brewer until it is in the CLAMP position again.
5. Check the timing. If necessary, repeat the adjustment steps until the roller is between the two timing marks when the brewer is in the CLAMP position.

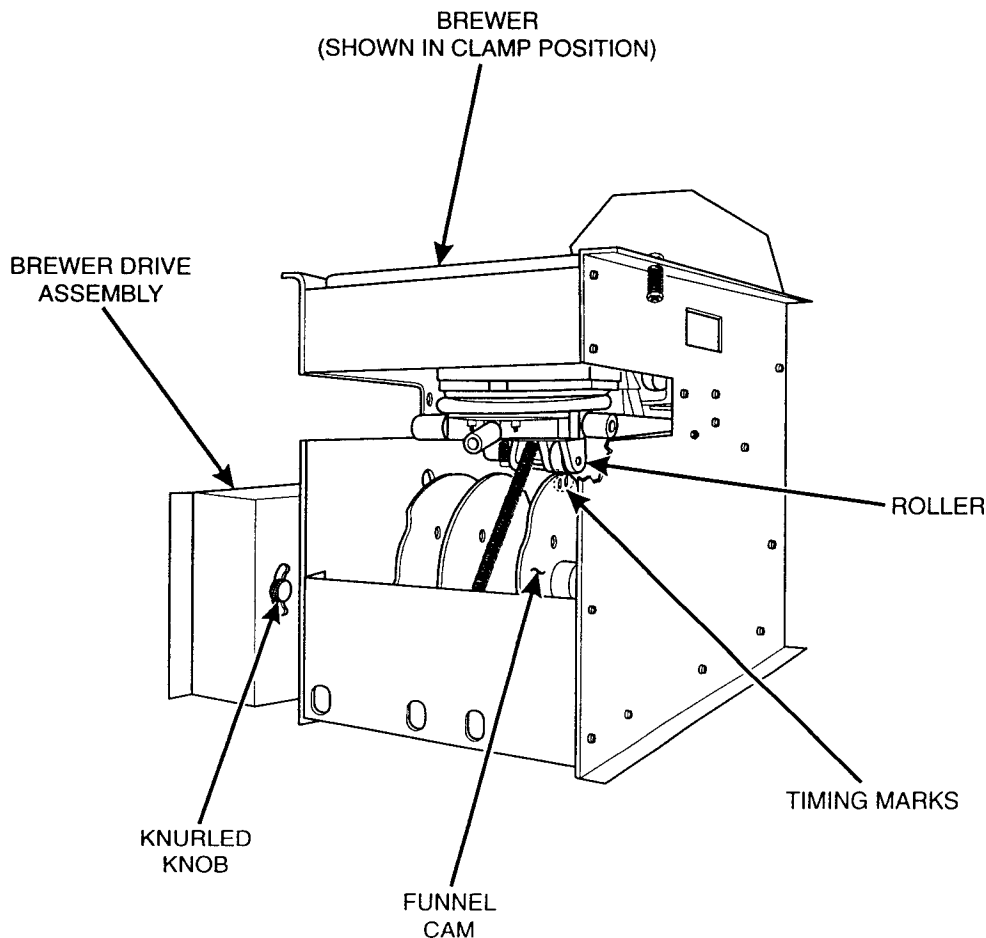

Hot Drink Module Setup, Operation and Service Manual

Cup Delivery Compartment Removal and Replacement

REMOVAL:

1. Lift the compartment from its mounting bracket and then remove the compartment from the cabinet.

REPLACEMENT:

1. Position the compartment over the mounting bracket. Lower the compartment until it hangs from the mounting bracket.

Cup Delivery Compartment Sanitizing

1. Remove the cup delivery compartment from the merchandiser.
2. Wash and sanitize the compartment.
3. Rinse the compartment with clean, hot water and dry thoroughly.
4. Return the cup delivery compartment to the merchandiser.

Beverage Discharge Nozzle Sanitizing

1. Disconnect the dispensing tube.
2. Turn the nozzle until its slotted web is in line with the slotted mounting hole in the bracket.
3. Remove the nozzle.
4. Remove the cap from the nozzle.
5. Clean and sanitize the nozzle and cap.
6. Replace the nozzle and cap.
7. Reconnect the dispensing tube.

CUP DELIVERY
COMPARTMENT
BRACKET
ASSEMBLY

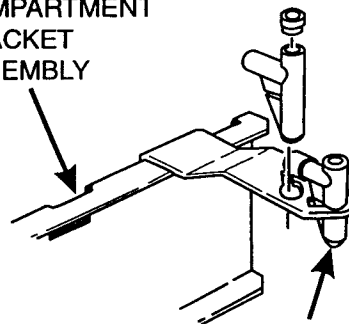

BEVERAGE
DISCHARGE
NOZZLE

Vent Blower Filter Removal and Replacement

REMOVAL:

1. Rotate the vent blower housing clockwise.
2. Lower the housing.
3. Remove the filter from inside the housing.

REPLACEMENT:

1. Place the new filter in the vent blower housing.
2. Position the housing over the mounting studs on the bottom of the blower assembly.
3. Rotate the housing counterclockwise to secure it in place.

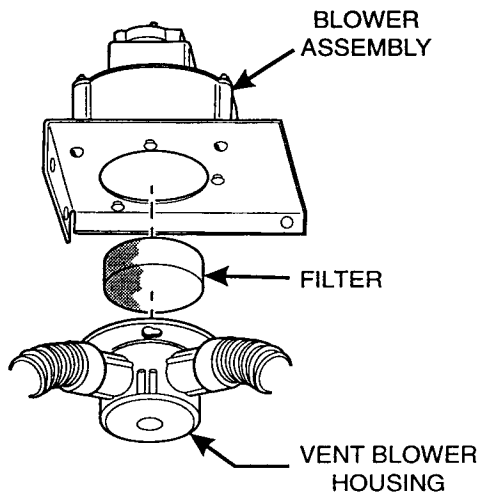

Hot Drink Module Setup, Operation and Service Manual

Grounds Pail Cleaning

1. Empty and rinse the grounds pail.
2. Reline the pail with a clean plastic trash liner.

Waste Pail Sanitizing

1. Empty, wash and sanitize the waste pail.
2. Sprinkle half of a handful of detergent powder in the bottom of the pail. This will help control odors from waste liquids.

Water Filter Cartridge Service Limits

Check the water filter cartridge installation record. There is a place to write the vend number on the cartridge.

- The effective limits of the cartridge are as follows:

7 oz cup	-	26,000 vends
8.25 oz cup	-	22,000 vends
9 oz cup	-	20,000 vends

NOTE

Local conditions may require more frequent replacement.

Measuring and Setting Water Temperature

The temperature of the water in the water tank is controlled by the temperature control thermostat.

WARNINGS

The water in the tank is very hot. Be careful when adjusting the temperature control thermostat.

110 VAC is present at thermostat terminals as shown. Make sure machine power is OFF before attempting to adjust the thermostat.

1. Place a cup in the cup station.
2. Initiate a water throw for the hot chocolate selection. See the *Programming Section* for the correct procedure.
3. Repeat steps 1 and 2 until you have thrown ten cups of water.
4. Wait 20 minutes to allow the temperature in the water tank to stabilize.
5. Place a cup in the cup station and initiate another water throw.
6. Measure the temperature of the water. Water temperature should be 190° to 200° F (88° to 93° C). Compare your reading with these values and adjust the thermostat accordingly:
 - a. Turn the main power switch OFF. Turn the thermostat adjustment screw clockwise to increase the temperature.
 - b. Turn the thermostat adjustment screw counterclockwise to decrease the temperature. Turn the main power switch ON.

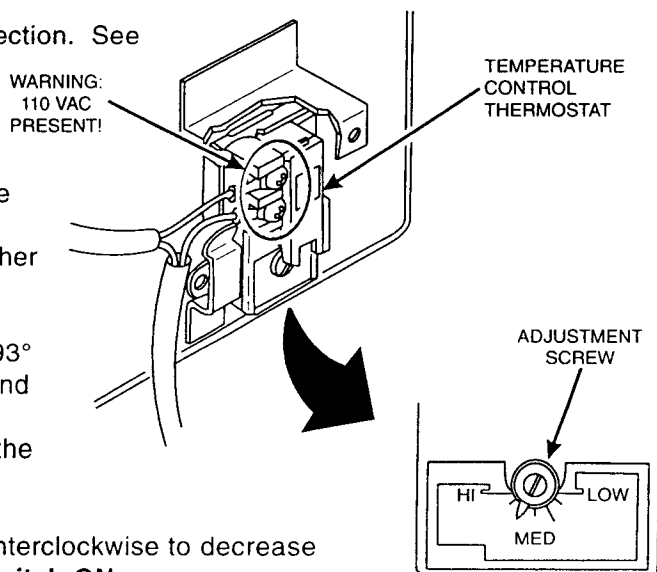

Hot Drink Module Setup, Operation and Service Manual

Dry Ingredient Air Fluffing

NOTE

This will help prevent the ingredients from compacting in the canister base.

1. Remove the canister from the merchandiser.
2. Hold the lid securely and invert the canister.

Sugar and Whitener Mixing Bowl Inspection

1. Look for an accumulation of sugar or whitener in the mixing bowl.
2. If necessary, clean and sanitize the bowl. See *MIXING BOWL SANITIZING*.

Dry Ingredient Shelf Cleaning

1. Remove the canisters from all of the shelves.
2. Clean the shelves with a damp, disposable wiper.
3. Allow shelves to thoroughly dry before replacing the canisters.
4. Replace the canisters.

Canister Sanitizing

1. Empty and wash the canister.
2. Sanitize the canister, lid, auger, and spout.
3. Rinse all parts in hot water.
4. Allow the parts to thoroughly dry before reassembly.
5. Reassemble the canister and return it to the merchandiser.
6. Load the canister with the appropriate ingredient.

Mixing Bowl Sanitizing

1. Remove the mixing bowl from the dry ingredient shelf assembly.
2. Wash, sanitize, and thoroughly rinse the mixing bowl.
3. Return the mixing bowl to the dry ingredient shelf assembly.

Hot Drink Module Setup, Operation and Service Manual

Chocolate Funnel and Impeller Housing Sanitizing

REMOVAL:

1. Disconnect the tubing from the funnel.
2. Remove the funnel.
3. Rotate the impeller housing clockwise.
4. Pull the housing forward and away from the mounting plate assembly.

SANITIZING:

1. Wash and sanitize the funnel and the impeller housing.
2. Rinse both with hot water and thoroughly dry them before replacing.

REPLACEMENT:

1. Reverse the removal procedure to replace the funnel and impeller housing.

CAUTION

Do not run water through the whipper unless the whipper is operating. Water can leak from the whipper chamber.

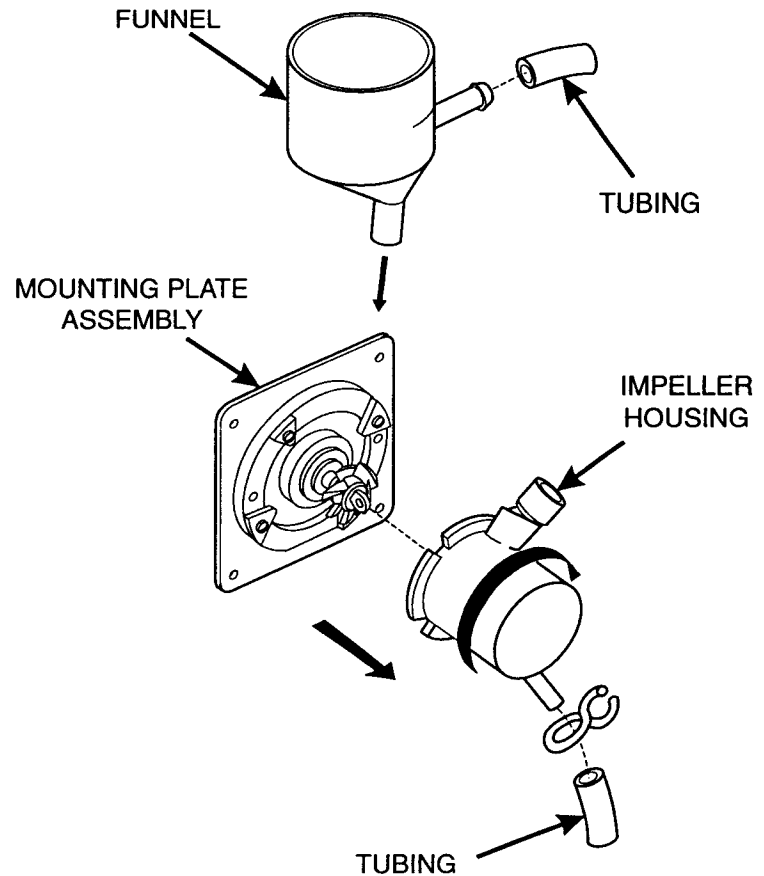

NOW WHAT?

There are still some things you need to do to complete setting up your merchandiser. Return to the same location in the *Main Setup Guide* that sent you to this booklet.