



Dixie-Narco[®], INC.

WORLDWIDE

**SERVICE
MANUAL
MPC SERIES I
VENDERS**

January 1, 1990
First Production XXXX - 3203DO

Index

General Information	2
Product Identification	5
Installation & Set-Up	6
Electrical Parts & Their Functions	15
Product Shimming	21
Adjustments: Cams/Rear Spacers	23
Sequence of Operation	27
Vender Trouble Shooting/Electrical Schematics	31
General Maintenance	40
Refrigeration Parts & Functions	43
Refrigeration Cycle	48
Refrigeration Trouble Shooting	50

WILLISTON, SC
Phone: (800) 688-9090
Phone: (803) 266-5000
FAX: (800) 266-5150

EASTLAKE, OH
Phone: (800) 321-0765
Phone: (216) 946-3000
Fax: (216) 942-1835

General Information

VENDER SAFETY PRECAUTIONS

This service information is intended to be used by a qualified service technician, who is familiar with proper and safe procedures to be followed when repairing, replacing or adjusting any Dixie-Narco vender components. All repairs should be performed by a qualified service technician who is equipped with the proper tools and replacement components, using genuine Dixie-Narco factory parts.

Repairs and/or servicing attempted by uninformed persons can result in hazards developing due to improper assembly or adjustments while performing such repairs. Persons not having the proper background may subject themselves to the risk of injury or electrical shock which can be serious or even fatal.

MODELS & DETAILS

DNCB 368

Height: 72
Width: 37-1/16
Depth: 30-1/2
Shipping Wt.: 690 lbs.
Capacity:
Can, 12 oz. 376
10 oz. PLB 352

DNCB 440

Height: 79-1/2
Width: 37-1/16
Depth: 30-1/2
Shipping Wt.: 748 lbs.
Capacity:
Can, 12 oz. 448
10 oz. PLB 432

DNCB 501T

Height: 72
Width: 37-1/16
Depth: 32
Shipping Wt.: 695 lbs.
Capacity:
Can, 12 oz. 501
Bottle, 16 oz. PLB 280

DNCB 600T

Height: 79-1/2
Width: 37-1/16
Depth: 32
Shipping Wt.: 800 lbs.
Capacity:
Can, 12 oz. 600
Bottle, 16oz. PLB340

PRODUCT WARRANTY

Dixie-Narco warrants to the original purchaser of a Dixie-Narco unit all parts thereof (except light bulbs, fuses or finish) to be free from defects in material and workmanship, under normal use and service for a period of 12 months from the date of shipment from either our plant or warehouse.

All conditions as set forth in this Warranty apply also to the Dixie-Narco Dollar Bill Validator, which is warranted for 15 months based on the coded date on the serial plate of the Validator or 12 months from the date of shipment, whichever is greater.

Dixie-Narco's obligation under this warranty is limited to repairing or replacing without charge any part, including the Dixie-Narco Validator which, upon our examination and to our satisfaction, was defective in material or in workmanship and which failed under normal operating conditions and service.

The hermetically sealed refrigeration system (included in the machine), consisting of the motor compressor, condenser, evaporator and the refrigerant tubing, is warranted for a total period of 60 months from date of shipment of the vender.

The vend motor is warranted for a total period of 60 months from date of shipment of the vender.

The 60-month warranty does not apply to any electrical controls, fan motors, overload switches, starting relays, temperature controls, wiring harnesses, cabinet or finish. Dixie-Narco's obligation under this warranty on the sealed refrigeration system referred to above is limited to repairing and returning or replacing at Dixie-Narco's option any unit with a similar unit when, upon examination and to our satisfaction, it was determined to have been defective. If our examination reveals that the unit is inoperative because of a defective accessory, both cost of repairs and freight charges will be paid by the customer.

Dixie-Narco will pay transportation charges under this warranty on all parts replaced or repaired when transportation has been made in the most economical way. If special handling or special transportation is used or requested, the charges will be paid by the customer.

This warranty only applies to units located within the United States and Canada and when operated in normal conditions and with electrical power supplies of 110/120 volts, 60 cycle. Further, the warranty is voided when the serial number is missing or when a unit or any part has been subject to defacing, vandalism, misuse, neglect, alteration without proper authorization, accident or damage caused by transportation, flood, civil disorder, fire, or the Acts of God.

"Return Material Tags," indicating model number of unit, serial number and explanation of defect, must accompany all returned parts or units. "Return Material Tags" will be furnished upon request.

Effective Date: December 1, 1987, 0730

Reprint: January 1, 1992

Product Identification

The age of Dixie-Narco products can be determined by the date code incorporated into the serial number.

The vender serial number takes the form xxxx-yyyzz. The first 4 digits (xxxx) identify the specific vender. The next 4 digits (yyyy) identify the manufacturing run that built the vender. The last two alpha characters (zz) identify the quarter and the year the vender was built. The first alpha character identifies the quarter:

- A = 1st quarter
- B = 2nd quarter
- C = 3rd quarter
- D = 4th quarter

The second alpha character identifies the year:

- | | | |
|----------|----------|----------|
| A = 1976 | K = 1986 | U = 1996 |
| B = 1977 | L = 1987 | V = 1997 |
| C = 1978 | M = 1988 | W = 1998 |
| D = 1979 | N = 1989 | X = 1999 |
| E = 1980 | O = 1990 | Y = 2000 |
| F = 1981 | P = 1991 | Z = 2001 |
| G = 1982 | Q = 1992 | |
| H = 1983 | R = 1993 | |
| I = 1984 | S = 1994 | |
| J = 1985 | T = 1995 | |

The Dixie-Narco Bill Acceptor serial number takes the form xxxxxxxx. The first 3 digits of the serial number are the date code. The first 2 digits are the month of manufacture and the 3rd digit is the last digit of the year of manufacture. For example, a bill acceptor built in December of 1990 would have a serial number starting with 120 (120xxxxx). A bill acceptor that was built in January 1991 would have a serial number starting with 011 (011xxxxx).

Installation and Set-Up

The Dixie-Narco MPC Series 1 can and bottle vender has been designed utilizing the latest technology featuring a highly sophisticated, micro-computer based control system. The vender design provides the flexibility required for the changing beverage industry as well as dependable performance for many years. This manual has been prepared to assist the proper installation and set-up of the vender. Please read this manual carefully and become familiar with the MPC Series Vender before placing the vender on location.

RECEIVING INSPECTION

When the vender is received inspect it for any damage. If there is any damage have the delivery driver note the damage on the bill of lading. According to I.C.C. regulations a shipping damage claim must originate with the consignee. Please advise Dixie-Narco as soon as possible if any shipping damage has occurred. Dixie-Narco will be happy to assist you if you must file a shipping damage claim.

UNPACKING THE VENDERS

Remove the stretch wrap and top cover from the vender. If flavor labels were shipped with your vender they will be in an envelope taped to the back of a vender in the shipment.

NOTE: *Do not store the vender outside with the stretch wrap on. This could cause the stretch wrap to bond to the vender's surface which could damage the finish.*

Remove the shipping boards from the bottom of the vender. The shipping boards are fastened to the base with the leveling legs. Remove the shipping boards by removing the leveling legs to avoid damage to the leveling legs or the base. A 1 1/2 inch socket type wrench can be used on the bottom of the leveling legs.

The door lock keys will be found taped in the coin return cup. Remove the keys and open the vender door. Remove all internal packaging. Check the coin box on the door for any extra parts, pricing labels, or other information on any factory equipped accessories. Check the handle for proper alignment and locking function. Check all lamps for proper function.

ELECTRIC POWER NEEDED

The vender uses 115 volts single phase, 60 cycle, alternating current. The voltage must be between 103 and 127 volts. Look at the cabinet serial number plate to determine how much current the vender requires. Be sure the Vender is plugged into a circuit which will provide correct amperage, with its own circuit protection (fuse, circuit breaker). Do not use an extension cord.

GROUND THE VENDER

The vender is equipped with a three wire grounded power supply cord. The vender **MUST** be plugged into a properly wired grounded outlet. **DO NOT REMOVE THE GROUND PIN OR USE ANY TYPE OF 3 PRONG TO 2 PRONG ADAPTOR.**

WARNING: Failure to comply with these instructions may subject the user to the risk of injury or electrical shock which can be serious or fatal.

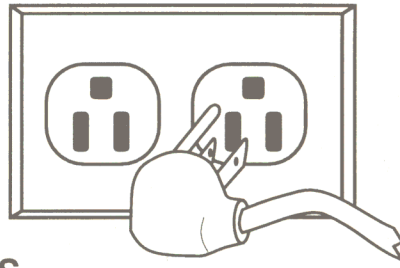

COIN CHANGERS AND OTHER ACCESSORIES

The MPC vender must have a coin changer installed and can have a bill acceptor installed. If the coin changer and other accessories are not factory installed refer to the instructions received from the manufacturer of the coin changer and other accessories for proper set-up and installation.

The MPC Vender can be equipped with either a controller style coin changer or a single price coin changer. The controller style coin changer must be used if multi-pricing is required. The controller style coin changer must be a 120 volt AC changer.

CAUTION: Do not use 24 volt changers in the Dixie-Narco MPC Series 1.

BILL ACCEPTORS/INTERFACE KITS

If a bill acceptor is not factory installed a bill acceptor interface kit must be ordered from Dixie-Narco. See the chart below:

ACCEPTOR	PEPSI COLA & OTHER VENDERS	COCA COLA VENDERS
Dixie-Narco USA	48x610 521,050,400.33	48x613 521,050,700.33
Mars VFM-1 & VFM-3	48x644 521,051,400.04	48x643 521,051,300.04
Maka	48x611 521,050,500.03	48x614 521,050,800.03
CoinCo/Rowe CBA-2		
\$1 Only	48x612 521,050,600.23	48x615 521,050,900.23
Rowe CBA-2		
\$1 & \$5 (UBA)	48x641 521,052,100.14	48x642 521,051,200.14

NOTE: Bill acceptors will be inhibited anytime the door interlock switch is in the center position (service mode enable) even if service mode time out has occurred restoring the vender to normal operation.

OTHER ACCESSORIES

The MPC Vender is capable of interfacing to Debit Card and Data Recording systems. At this time only a few such accessories have been tested by Dixie-Narco. If such accessories are to be used check with either Dixie-Narco or the accessory manufacturer about physical and electrical compatibility before attempting to interface such accessories to the MPC Series 1 Vender.

INSTALLING A SINGLE PRICE COIN CHANGER

Set the vend price according to the instructions for the coin changer. Also set the escrow mode in the coin changer to "Escrow to Price" and if required, set the coin changer for the proper bill acceptor interface. Hang the coin changer on its mounting panel and secure it by tightening the three securing screws. Plug the coin changer into the 8 pin Jones socket in the vender.

CAUTION: *The coin changer must be plugged in with the power removed from the door or the coin changer may not power on properly.*

If a bill acceptor is being used, the bill acceptor must be interfaced to the coin changer not to the MPC control board.

After restoring power, manually load the coin changer coin tubes with at least 10 coins each. Following the program instructions for the MPC Series 1 Vender, program Selection #1 for the same price that is set in the coin changer. This will enable the display and the accounting functions to operate properly. After the pricing is set return the vender to its operate mode by either closing the door or pulling the door closed switch out. "Prime" the coin changer by making one correct change transaction.

For free vend set program selection #1 to 0.00 and unplug the coin changer.

The following single price coin changers will work properly with the MPC Vender:

MARS ELECTRONICS INT.	COIN ACCEPTORS, INC.
TRC 6200	3340-S
TRC 6200C	9340-S
TRC 6800	9360-S
TRC 6800H	9370-S
TRC 6800C	S75-9400B-977
TRC 6800HC	S75-9800B-907
MC 5802	S300E-9240
MC 5800	
MC 5800DH	

CRANE INT.

525E 500
525C 510
525EC C-3000

CONLUX-USA

US-111A-1
US-111AD-1D
USP-121A-OC

INSTALLING A CONTROLLER STYLE COIN CHANGER

A controller style coin changer must be used if multi-pricing is required. The following controller style coin changers will work properly with the MPC Series 1 Vender.

Mars TRC6000
CoinCo 9300L
Maka USPX001

CAUTION: *Do not use a 24vac controller style coin changer in the MPC Series 1 vender. Damage to the coin changer and the vender may result. Use only 120vac controller coin changers.*

Hang the coin changer on its mounting plate and secure it by tightening the three securing screws. Plug the coin changer into the 15 pin Jones socket in the vender. The 15 pin Jones socket is designed to accept the 12 pin plug used on controller style coin changers.

CAUTION: *The coin changer must be plugged in with the power removed from the door or the coin changer may not power on properly. If a bill acceptor is being used, the bill acceptor must be interfaced to the MPC Series 1 control board.*

After restoring power, manually load the coin changer coin tubes with at least 10 coins each. Following the program instructions for the MPC Series 1 Vender, program each selection for its own vend price. A price of \$0.00 is free vend. After the pricing is set return the vender to its operate mode either by closing the door or pulling the door closed switch out. "Prime" the coin changer by making a correct change transaction.

NOTE: *If using a Mars TRC-6000 coin changer function switch #4 in the coin changer, must be set in the off position (down).*

PROGRAMMING THE MPC SERIES 1 VENDER

In order to program the MPC Series 1 Vender, it is necessary to enter the Service Mode. This is done by opening the inner door and pressing the "Service Switch" on the control board. At this time the display should read S-t. If the display reads 1.00 then the door interlock switch did not go to its center position or the switch is defective.

NOTE: *The door interlock switch has three positions. Fully in and fully out puts the vender into its normal mode. When the switch is in its center position the Service Mode can be entered.*

There is a time out for the Service Mode such that if no accounting or set-up functions are used for 2 minutes the vender will return to its normal mode. After time out the service switch on the control board has to be pressed to re-enter the Service Mode.

The following notes apply to the programming functions:

1. All accounting functions are historical and non-resettable. The meter roll over points are:

\$42,949,642.96 for sales total (st)

4,294,967,296 for product counts (HPt and HPC)

2. Coin dump (c-d) works only with a controller coin changer.
3. Escrow to select will allow a customer to cancel sale anytime before a selection is made. Escrow to select provides two bill acceptor escrow modes. **NO BILL ESCROW** stacks all bills and a cancel sale will be paid from the coin changer. **LAST BILL ESCROW** will hold the last bill required to meet or exceed the maximum vend price. A cancel sale will return the held bill from the bill acceptor, plus any deposit amount above a dollar from the coin changer. Last Bill Escrow will work only with a low level bill acceptor such as the Dixie-Narco USA. Maximum possible deposit is \$0.95 plus the maximum vend price.
4. Escrow to price will not allow a cancel sale if the minimum vend price has been met or exceeded. There is no bill escrow in this mode.
5. The escrow functions work only with a controller coin changer. When using a single price coin changer the escrow to price mode must be set in the coin changer.
6. If 0.00 is entered for a price, that selection will free vend when using a controller coin changer.
7. The maximum vend price that can be programmed is \$9.95.

The Service Mode functions are divided into two basic groups.

Group 1—is used to read accounting functions.

Group 2—is used to set-up functions.

All Service Mode functions are accessed and changed by using the vender select buttons. There are 2 selection panel button configurations used by Dixie-Narco. The first are in-line and the other is side by side.

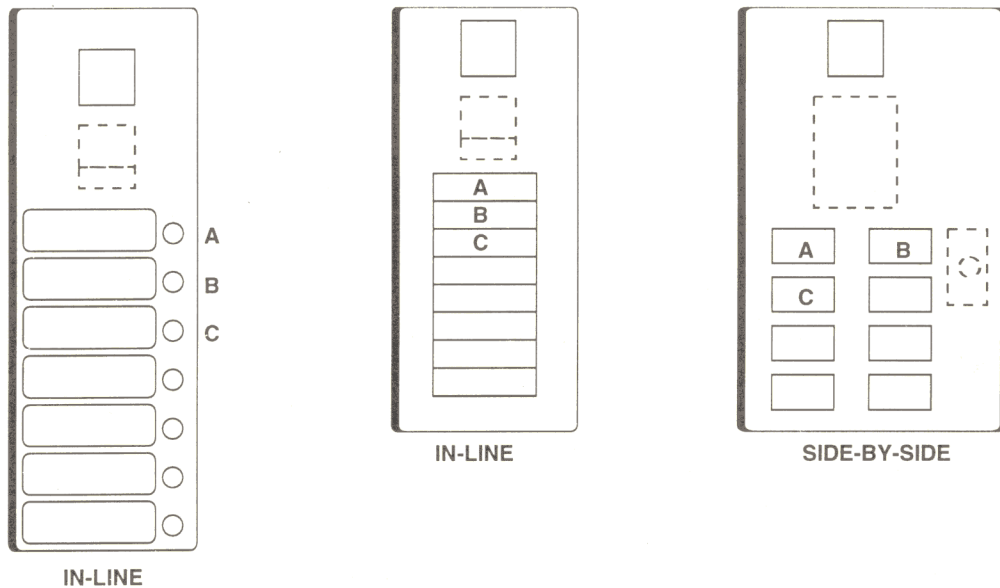

When the Service mode is entered the vender starts with the Group 1 accounting functions. The 3 accounting functions will repeat with successive pushes of select buttons A + B. If the Group 2 set-up functions are entered the 4 set-up functions will repeat with successive pushes of select buttons A + B. The following shows the different displays and explains the different modes.

GROUP 1

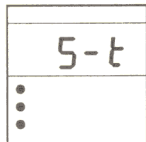

SALES TOTAL

This function displays the total cash collected by this vender. Push any selector switch.

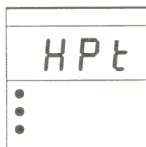

HISTORICAL PRODUCT TOTAL COUNT

This function is used to display the total number of vends from the machine. Push any selector switch.

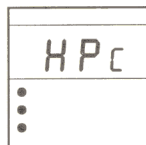

HISTORICAL PRODUCT COUNT

This function displays the number of vends from each column in the machine. To display the number for a column. Press the selector switch for that column.

To switch from group 1 to group 2, hold switches A+B pushed at the HPt display. The display changes to HPC first, after 5 seconds the display changes to C-d.

GROUP 2

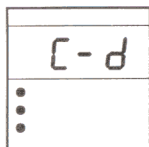

COIN DUMP

This function is used to dump coins from the coin acceptor. The first selector switch A is used to dump nickels. The second selector switch B is used for dimes and the third selector switch C is used for quarters.

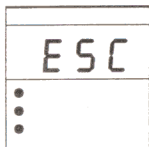

ESCROW

This function is used to display and change the escrow condition. To display the escrow condition, push any selector button.

To change the escrow condition:

Hold select button A *P-r will be displayed. The escrow condition is escrow to price. All dollar bills will be stacked. No cancel sale is allowed once the minimum vend price is met or exceeded.

Hold select button B *E-S4 will be displayed. The escrow condition is escrow to select with the dollar bills being stacked. Cancel sale will return the deposit from the coin changer

Hold select button C *E-S1 will be displayed. The escrow condition is escrow to select with the last dollar bill that meets or exceeds maximum vend price being escrowed in the validator. Cancel sale will return the held dollar bill and any amount over \$1 will come from the coin changer.

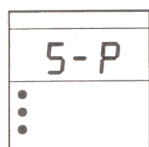

SET PRICE

This function is used to set the price of each selection. When a selector switch is pushed, the price for that selection will be displayed. If the switch is held pressed, the price will increment or decrement. To change from one to the other, release the selector switch then push it again.

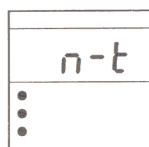

MOTOR TEST

This function is used to run the motors. To test a motor, push the selector switch for that column

To switch from group 2 to group 1, hold switches A+B pushed at the S-P display. The display changes to n-t first, after 5 seconds the display changes to S-t.

PLACING THE VENDER ON LOCATION

CAUTION: *Do not transport the vender to or from the location loaded with product or damage to the vender may result.*

The vender should be located on a solid, as flat as possible, surface. **CAUTION:** Local loading under the leg levelers must be capable of 225 P.S.I. The vender must be positioned close enough to an electrical outlet that an extension cord is not required. If securing the vender to the floor or wall is required, call the Dixie-Narco Factory Service Department or your Dixie-Narco Representative for securing suggestions.

LEVEL THE VENDER

Level the vender. When the vender is level the door can be opened to any position and it will not move by itself. Open the door to several different positions before deciding that the vender is level.

Make sure that all of the leveling legs are touching the floor.

DANGER: *The vender must be properly located and leveled to minimize the risk of injury or death from tip-over in the event of user misuse or vandalism.*

SPACE THE VENDER

Do not block the rear of the vender. Keep the vender 4 inches from the wall to provide adequate ventilation for the condenser and compressor. Also in front of the vender, make sure that nothing obstructs the air intake at the bottom of the door.

LOADING THE VENDER

All MPC Series 1 Venders are shipped ready to vend 12 oz. cans unless another package was specified at the time the vender was ordered from the factory. If a package other than a 12 oz. can is to be vended contact a Dixie-Narco Factory Service Representative, or refer to the proper service bulletin for spacer settings and shims.

INITIAL LOADING

Oscillators must be in the extreme left or right position to insure proper loading. When loading wide columns, the first row of cans should be loaded on the bottom bar of the oscillator. The second row of cans must be loaded on the top bar of the oscillator. Always load complete rows, do not load only to the back or only to the front of the column. Rotors must be in the "cup" position to receive the first cans. When loading narrow columns lay the rows in the column until the column is full.

Do not fill the columns to the top of the cabinet. Allow about 3 inches at the top of the column because the can stack will move up and down in the column during the vend cycle. Correct loading will prevent service calls and insure proper vending.

After loading a vender for the first time test vend each selection with money until the first can is delivered. This will ensure that the vender is loaded and working properly.

NOTE: To insure proper air flow through the evaporator, do not place cans (or other foreign objects) in the bottom of the tank.

INSTALLING FLAVOR CARDS AND PRICE LABELS

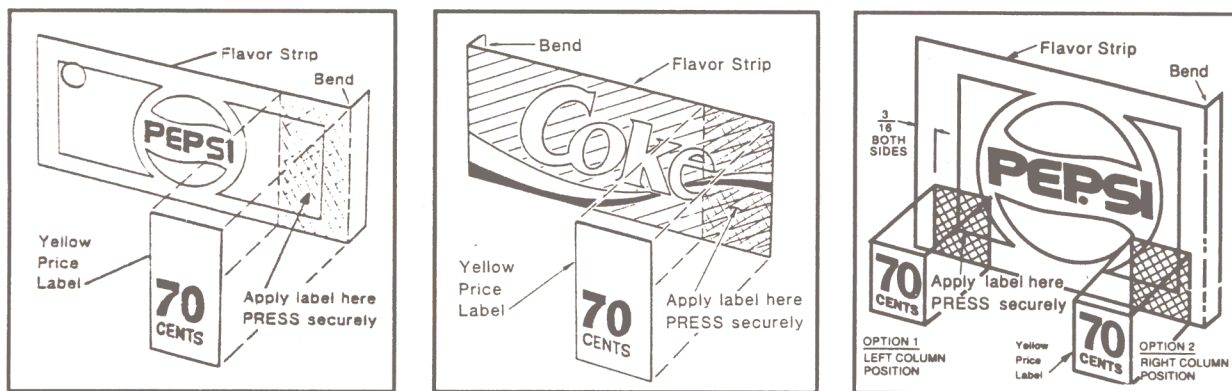

In the MPC Series 1 Vender the price labels are fastened to the flavor cards before the flavor cards are inserted into the selection buttons. To insert the flavor cards into the selection buttons swing the coin changer mounting plate away from the outer door exposing the back of the selection buttons. The flavor cards can be inserted into the back of the selection buttons from either side. Ensure that the flavor cards are placed in the selection buttons that correspond to the columns the product is in.

Electrical Parts and Functions

CORRECT CHANGE LAMP



The correct change lamp is mounted in the coin insert casting and is retained by projections on the top and bottom.

The correct change lamp is controlled by the MPC Series 1 Controller board and is "OFF" when coins are in the tubes of the coin changer.

SELECT SWITCH

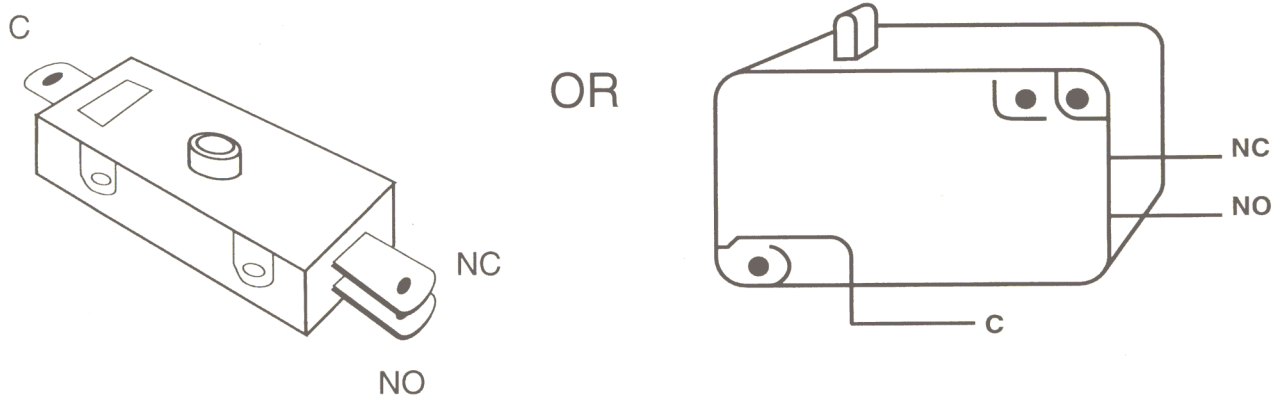

The select switch is located in the selector panel behind the push button and is secured with two (2) screws.

The N.O. contact of the Select Switch is in the MPC Series 1 control board and vend motor coil circuits. This N.O. contact closes and completes the MPC Series 1 Control Board Circuit and the vend motor coil circuit.

The N.C. contact of the Select Switch is in the Select Panel Circuit.

SOLD OUT SWITCHES

The Sold Out Switches are located on the front mechanism plate under the Vend Motor Cover.

The Sold out Switches are the “snap in” type. To install, place the switch in position over the opening, push in and at the same time, slide to the right.

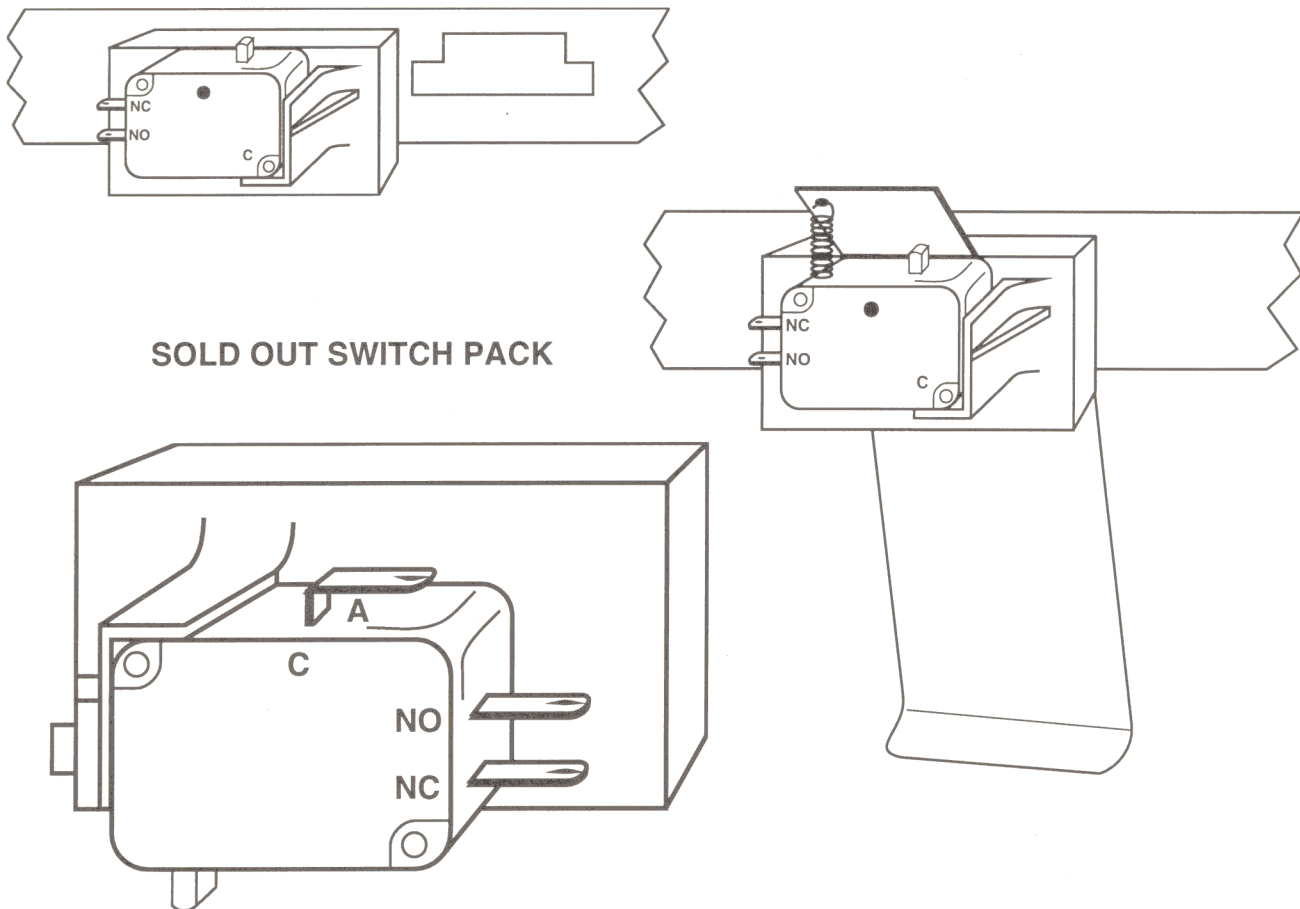

SOLD OUT SWITCH PACK

The sold out switch pack (one for each vending circuit) is located near the bottom of the column at the front and snaps into place.

VEND SOLD OUT SWITCH

The N.C. contact of the sold out switch has no function. The N.O. contact of the Sold Out Switch is in the Sold Out Lamp circuit (kept open by a can or bottle). When not kept open by a can or bottle, the N.O. contact closes and completes the Sold Out Lamp circuit via the MPC Series 1 controller board.

SOLD OUT LAMPS

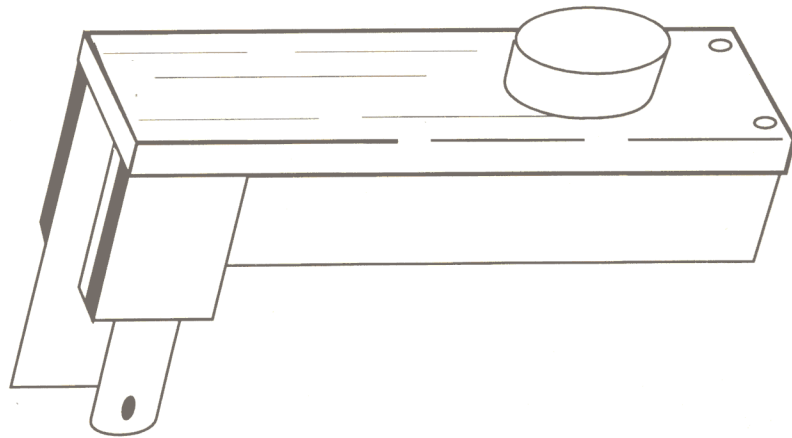

The Sold Out Lamp (one for each vending circuit) is secured to the back of the select button in the Selector Panel.

The Sold Out Lamp is turned on by the closing of the N.O. contacts of the Sold Out Switch.

VEND MOTOR

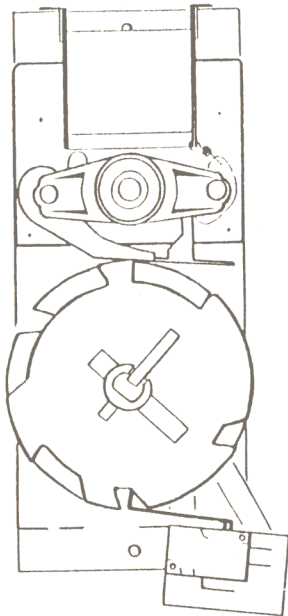

For Narrow Column

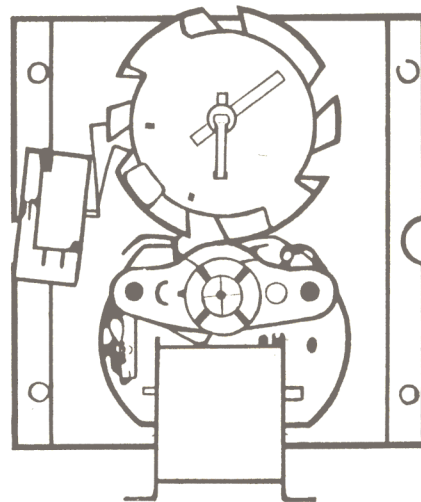

For Wide Column

The Vend Motor (one for each vending stack) is mounted on a bracket at the front of the vender.

The Vend Motor is in the Vend Motor Coil Circuit. The Vend Motor runs when a N.O. select switch (pushed) closes and completes the Vend Motor Coil Circuit. The Vend Motor continues to run through the N.O. contact (closed by the Vend Motor Cam) of the Vend Motor Switch. The Vend Motor stops when the Vend Motor Switch arm drops off the high side of the Vend Motor Cam.

VEND MOTOR SWITCH

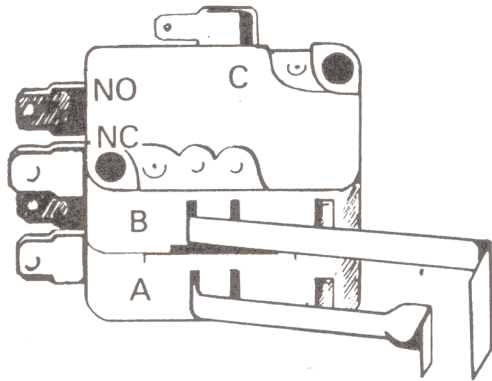

For Wide Columns

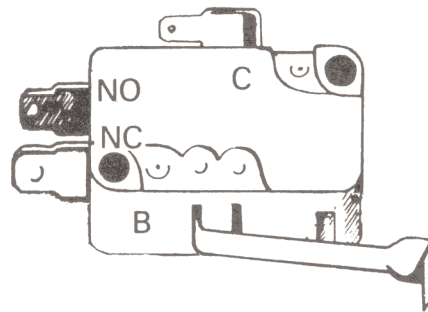

For Narrow Columns

A. VEND MOTOR SWITCH

The Vend motor/by-pass switch (on wide columns) are together and do not come apart. The **Vend Motor Switch**, one (1) for each circuit, is located on the Vend Motor Assembly and secured by two (2) screws.

The N.O. contact of the Vend Motor Switch is in the Vend Motor Coil Circuit. This N.O. contact closes in the Vend Motor Coil Circuit to keep the Vend Motor running and at the same time lights the sold out light, until the arm of the Vend Motor Switch drops into the cam notch and the Vend Motor stops.

The N.C. contact of the Vend Motor Switch has no function.

B. BY-PASS SWITCH

(on wide columns only)

The Vend Motor/By-Pass switches for wide columns are together and do not come apart. The **By-Pass Switch**, one (1) for each wide column circuit, is located on the Vend Motor Assembly secured by two (2) screws.

The N.C. of the By-Pass Switch is in the Vend Motor Coil Circuit. The N.C. contact closes in the vend motor coil circuit to keep the vend motor running until the N.O. contact of the vend motor switch closes to keep the vend motor running.

VEND MOTOR WIDE COLUMN

Mounted on the vender with the Vend/By-Pass switches on the left side (See Fig. 3).
The linkage and drive arm assembly is used to connect the vend motor to the oscillator.
(See Fig. 4)

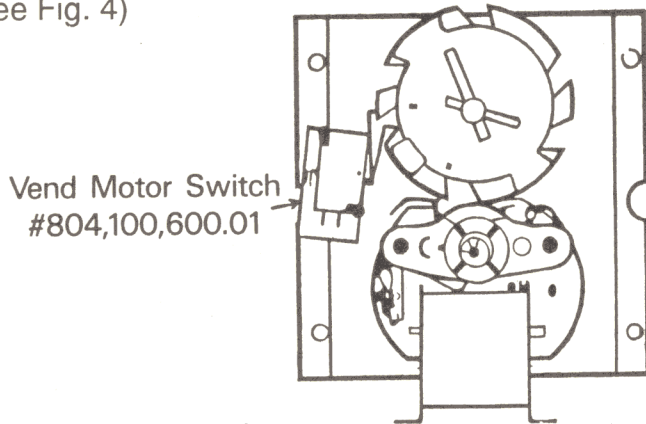

Vend Motor - Wide Column
#491,070,300.03 - 1 1/4"
#497,070,800.03 - T Models

Fig. 3

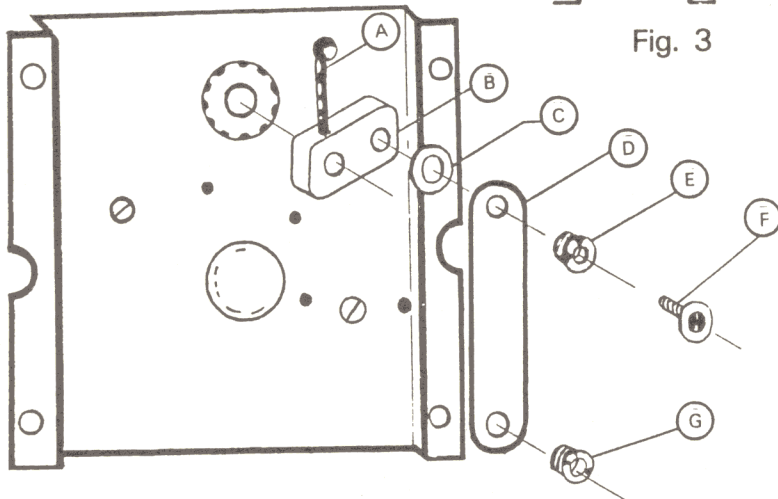

A. Drive Pin	#900,901,940.01
B. Drive Arm	#801,200,450.51
C. Washer	#900,700,600.01
D. Linkage Arm	#A801,201,030.01
E. Nyliner (Top)	#801,803,160.01
F. Sems Screw	#900,301,640.01
G. Nyliner (Bottom)	#801,804,770.01

Fig. 4

Nyliner (Rear Stack)
#801,803,170.21

Can Retainer
901,700,650.01

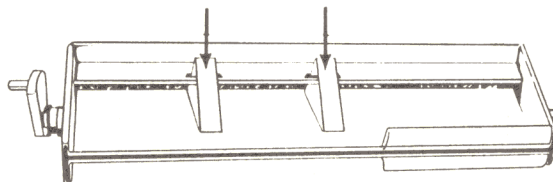

Oscillator Assembly
491,070,900.03 - 1 1/4"
497,071,000.03 - T Models

Nyliner (Front Stack)
#901,804,230.01

Sold Out Spring
#901,700,740.01

Sold Out Switch Assy. Snap In
#804,100,630.01
(Insulator and Switch are one (1) piece)

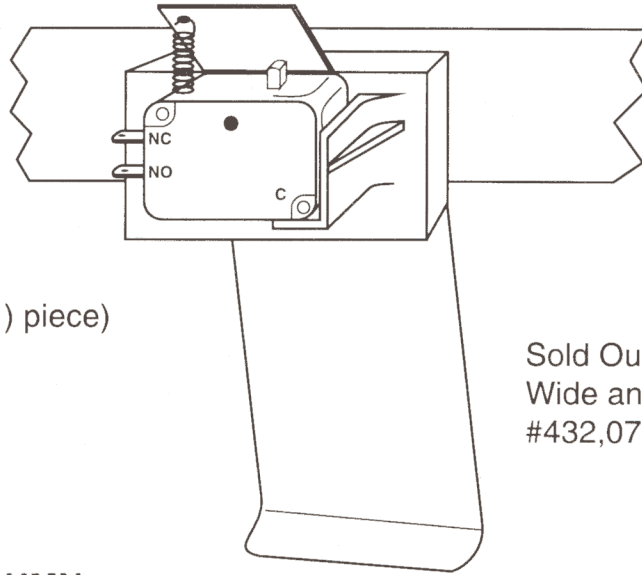

Sold Out Paddle
Wide and Narrow
#432,070,190.13

VEND MOTOR NARROW COLUMN

Mounted on the vender with the Vend/Motor switch on the underside (See Fig. 1). The shaft of the vend motor slides into a slot in the vend rotor (See Fig. 2).

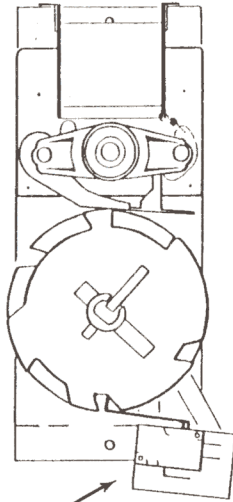
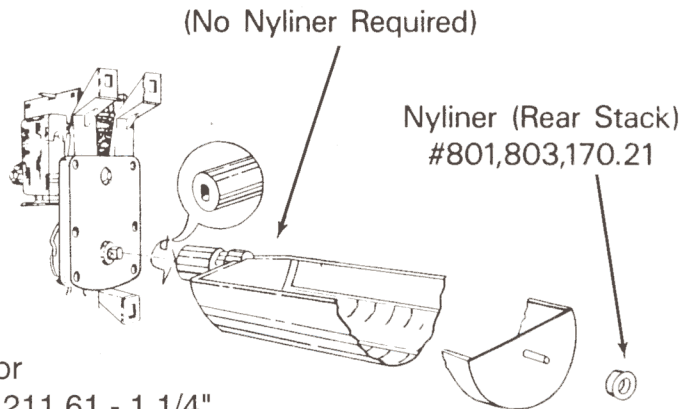

Figure 1

Vend Motor Switch
#804,100,550.01

Vend Motor - Narrow Column
#530,070,200.03 - 1 1/4"
#551,070,200.03 - T Models



Vend Rotor
#801,201,211.61 - 1 1/4"
#801,201,220.01 - T Models
#801,201,230.01 - Triple Depth Can Rotor, T Models

Figure 2

Product Shimming

Refer to the appropriate Technical Bulletin for proper set-up and vending procedures. Listed are a few of the more widely used Technical Bulletins.

TECHNICAL BULLETIN 377

For 5,6,8, and 10 column Adaptable and Dual Adaptable 1 1/4" Deeper Shimless Stack venders. Serial #'s 0001-3098AN and up. Also, identified with a large decal on motor cover or sold out bar cover reading; **SHIMLESS STACK**.

NOTE: No shims are needed to vend 12 oz. cans or 10 oz. PLB bottles.

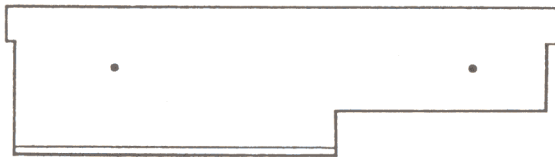

10 oz. can shim (rimless)
6 & 8 column venders
#463,010,010.03



10 oz. can shim (rimless)
10 column venders
#350,010,010.03

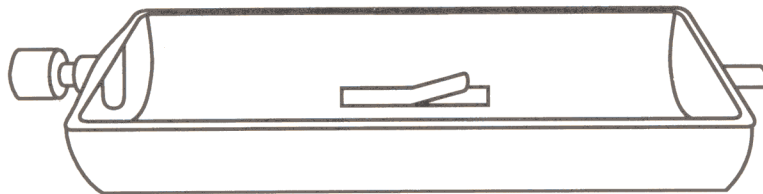

Shimless Rotor 1 1/4" deeper
#801,201,210.01

TECHNICAL BULLETIN 282

For 8 column "T" model (501's and 600's). This includes both pre-series 90 and Series 90 T Models. Serial #'s 0001-2775 DI to 0001-6090CQ.

TECHNICAL BULLETIN 438

For 8 column "T" model (501's and 600's). Serial #'s 0001-6090CQ and Up.

For shimming of venders or products not listed in the above Technical Bulletins, call the Dixie-Narco Service Department or contact your Dixie-Narco Representative.

From **TECHNICAL BULLETINS 282 & 438** (501T and 600T - triple depth can venders)



Front view

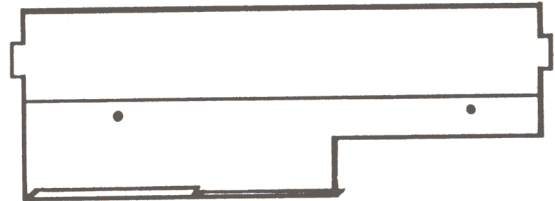
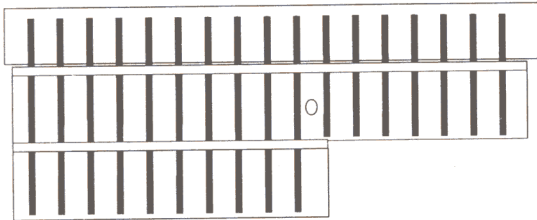

Can Stop Shim
#497,070,130.83

Rear view

Left hand ribbed shim for 12 oz. cans (shown above)

#801,804,900.01

Right hand ribbed shim #801,804,890.01 (Not shown)

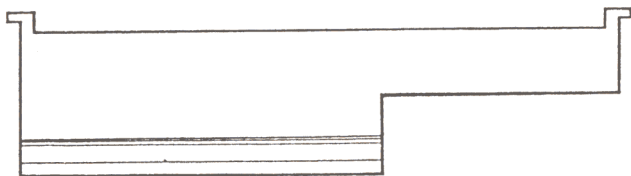

Bubble shim for 16 oz. PLB
#361,010,080.43

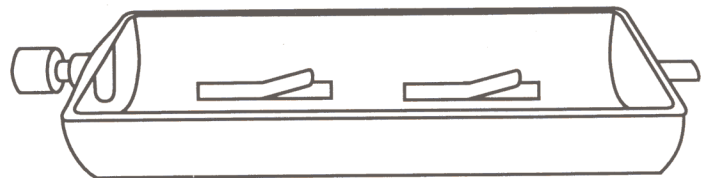

Triple-Depth Can Rotor
#801,201,230.01

Adjustments Cams and Rear Spacers

CAMS FOR VEND MOTORS

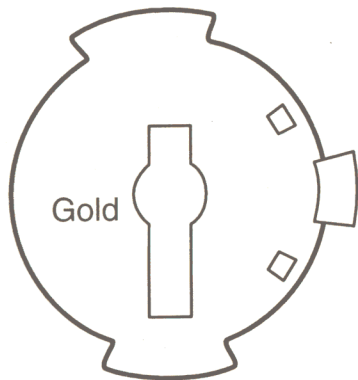

1. Adjustable Cam For:

- a. DNCB 1 1/4" deeper wide column.
- b. DNCB T Models single, double or triple depth wide column.
- c. Color of Cam is Gold.
- d. Part #801,806,400.11

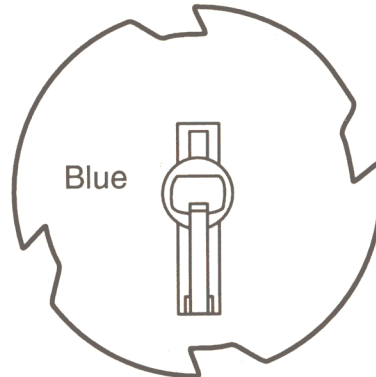

2. Vending Cam For:

- a. DNCB 1 1/4" deeper single or double depth wide column.
- b. DNCB T-Models single depth wide column.
- c. Color of Cam is Blue.
- d. Part #801,806,390.11



3. Vending Cam For:

- a. DNCB T Models double or triple depth wide column.
- b. Color of Cam is Green.
- c. Part #801,806,410.01.

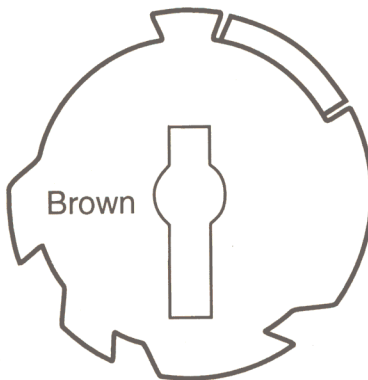

4. Adjustable Cam For:

- a. DNCB 1 1/4" deeper narrow column.
- b. DNCB T Models single, double or triple depth narrow column.
- c. Color of Cam is Brown.
- d. Part #801,806,610.21.

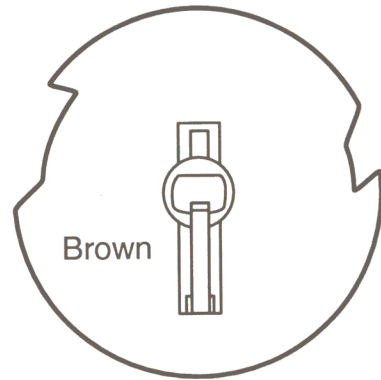

5. Vending Cam For:

- a. DNCB 1 1/4" deeper narrow
- b. DNCB T Models single, double or triple depth narrow column.
- c. Color of Cam is Brown.
- d. Part #801,806,180.21.

CAM INSTALLATION AND REMOVAL

TO INSTALL A VENDING CAM:

1. Select the vending cam required (See page 23).
2. Locate the hub at the center of the cam (See Fig. 6).
3. With the hub facing you, slowly slide the cam onto the front shaft of the vend motor while depressing the lock tab. (See. fig. 6).
NOTE: Reference below for timing of the motors.
4. A distinct click will be heard, when the tab has locked into the locator hole of motor shaft.

CAUTION: *Depress the switch arms when installing the cam to prevent possible damage to the switch arms.*

TO INSTALL AN ADJUSTABLE CAM:

1. Select the adjustable cam required. (See page 23).
2. Locate the lift tab on the outer edge of the cam. (See fig 5)
3. With the lift tab facing you, align the slot of the adjustable cam with the locking tab of the vending cam.
4. Place the adjustable cam onto the vending cam.

CAUTION: Depress the switch arms when installing the cam to prevent possible damage to the switch arms.

5. Lift the lock tab of the vending cam, at the same time lift the lift tab of the adjustable cam and rotate the adjustable cam clockwise to the desired setting.

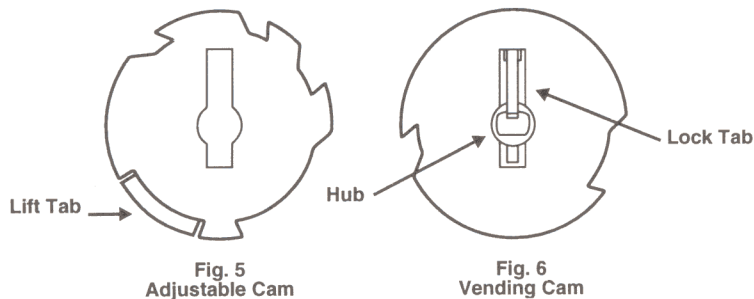

TO REMOVE AN ADJUSTABLE CAM:

1. Lift the lift tab and rotate the adjustable cam clockwise until the vending cam lock tab is aligned with the slot of the adjustable cam.
2. Remove the adjustable cam from the shaft of the motor.

TO REMOVE THE VENDING CAM:

1. Depress (push in) the lock tab firmly to disengage it from the motor shaft.
2. At the same time pull the vending cam towards you until it is removed from the motor shaft.

TIMING

TO SET THE TIMING OF A NARROW COLUMN VEND MOTOR:

1. Make sure the hole through the rear shaft is in a horizontal plane. (If a pin were inserted in the hole, the pin would be horizontal.) See Fig. 8.
2. The vend rotor must be in the loading position when the motor shaft is inserted into the end of the rotor. See Fig. 8.
3. Insert the motor shaft into the rotor and secure the motor.
4. Install the vending cam onto the front shaft of the motor making sure the lock tab is at the 9 o'clock position. See Fig 7.
5. Install the adjustable cam per the instructions on page 24.

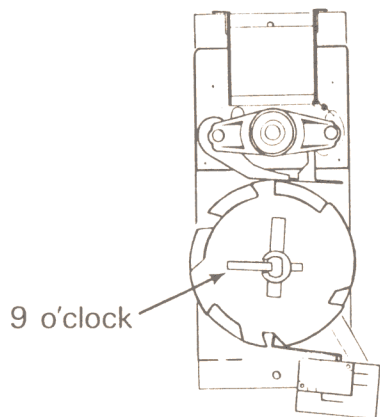

Fig. 7.

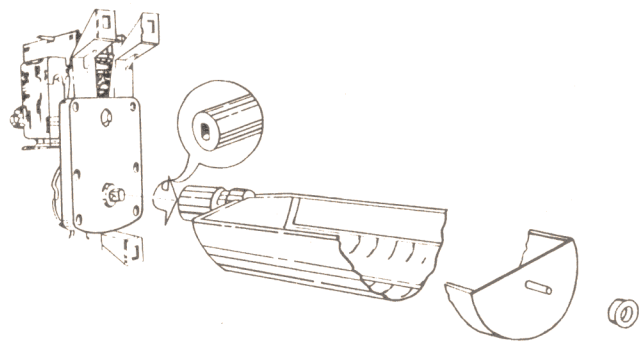

Fig. 8

TO SET THE TIMING OF A WIDE COLUMN VEND MOTOR.

1. Make sure the hole through the rear shaft is in a horizontal plane. (If a pin were inserted in the hole, the pin would be horizontal). See Fig. 10, page 26.
2. Slide the Drive Arm (with linkage attached) onto the rear shaft as shown. See Fig.10, page 26.
3. Secure by installing the groove pin.
4. With the oscillator in position, align the hole in the linkage arm with the pin of the oscillator.
5. Slide the linkage onto the pin.
6. Install the vending cam onto the front shaft of the motor making sure that the lock tab is at 6 o'clock as shown. See Fig. 11, page 26.

NOTE: When the screw holding the linkage arm to the drive arm is at the 12 o'clock position (See Fig. 10), the lock tab will be at the 6 o'clock position (See Fig. 11).

7. Install the adjustable cam per the instructions on page 24.

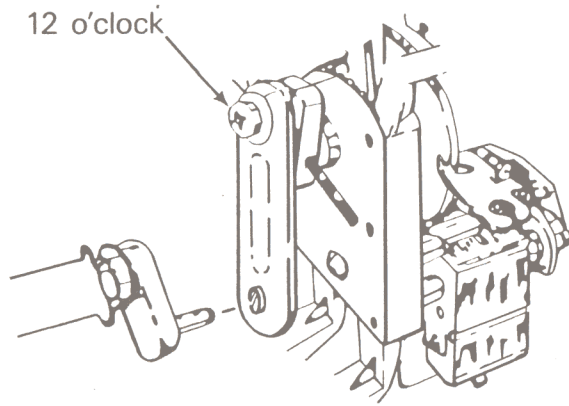

Fig. 10

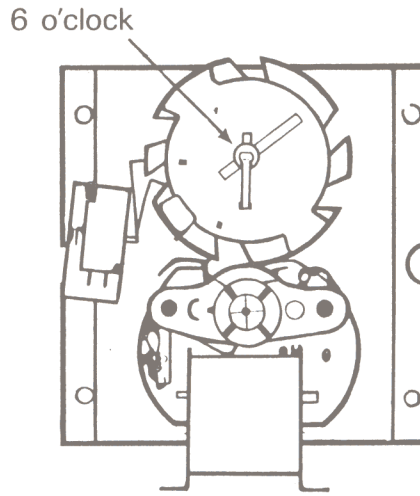

Fig. 11

REAR SPACER

The rear spacer, one for each column, is located vertically at the rear of the column. The latch fingers, adjustable by hand, slide into the holes in the column wall for cans and other package settings.

See Fig. 14, the latch fingers are in the open position with the lock tabs disengaged.

See Fig. 13, the latch fingers are in the closed position with the lock tabs engaged. Make sure the tabs are in a locked position as shown, before loading the vender.

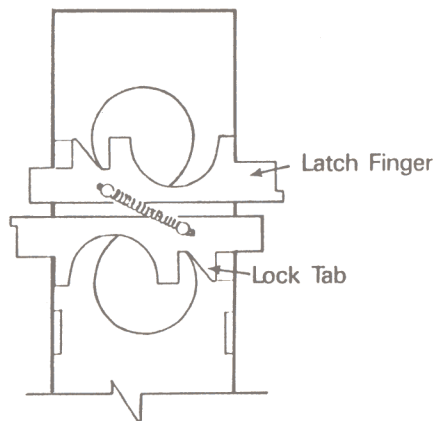

Fig. 13
Rear Spacer

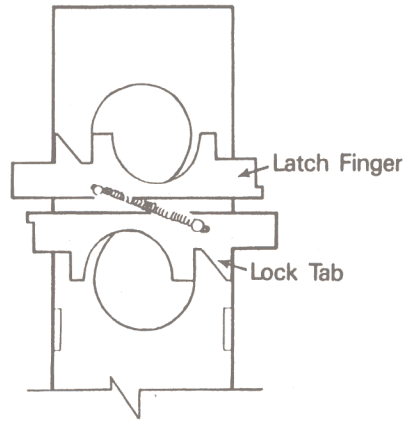
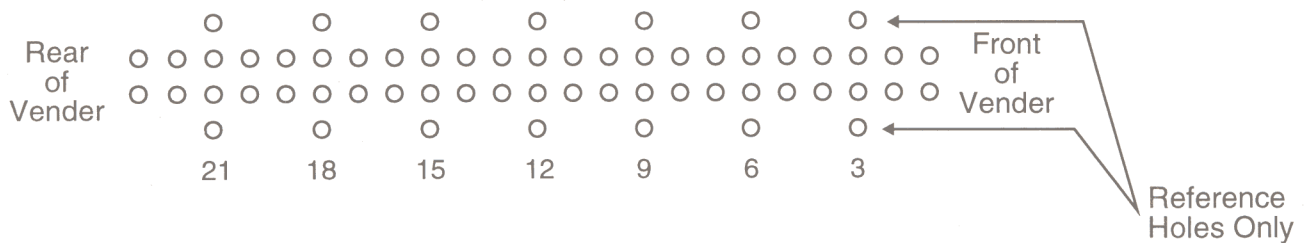

Fig. 14
Rear Spacer

FOR REFERENCE ONLY

Rear spacer adjustment holes located in the sidewalls of the stacks.



Sequence of Operation

MPC SERIES 1 SEQUENCE OF OPERATION CONTROLLER STYLE CHANGERS ESCROW TO PRICE AND NO BILL ESCROW (Pr)

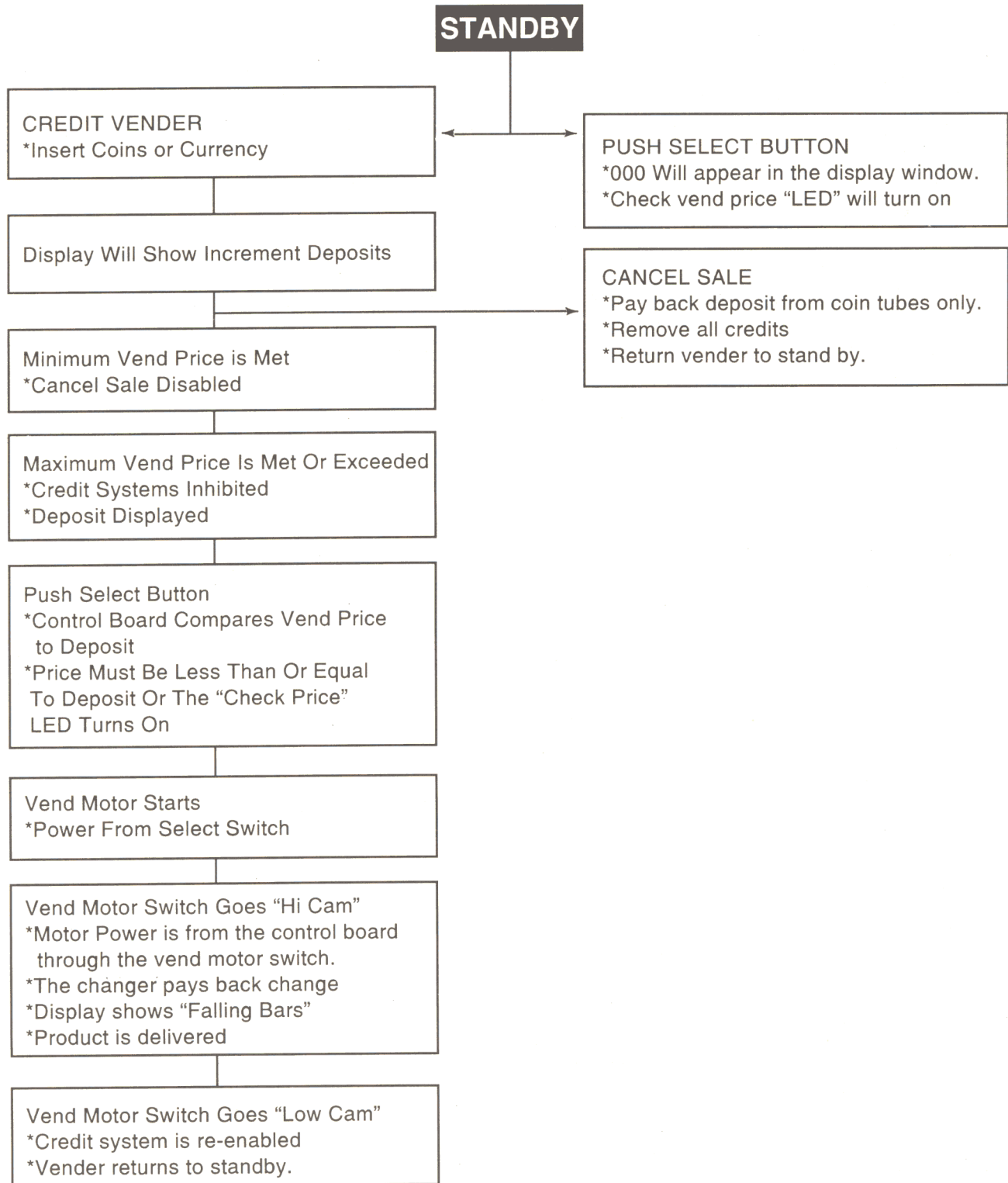

**MPC SERIES 1 SEQUENCE OF OPERATION
CONTROLLER STYLE CHANGERS
ESCROW TO SELECT AND NO BILL ESCROW (E-S4)**

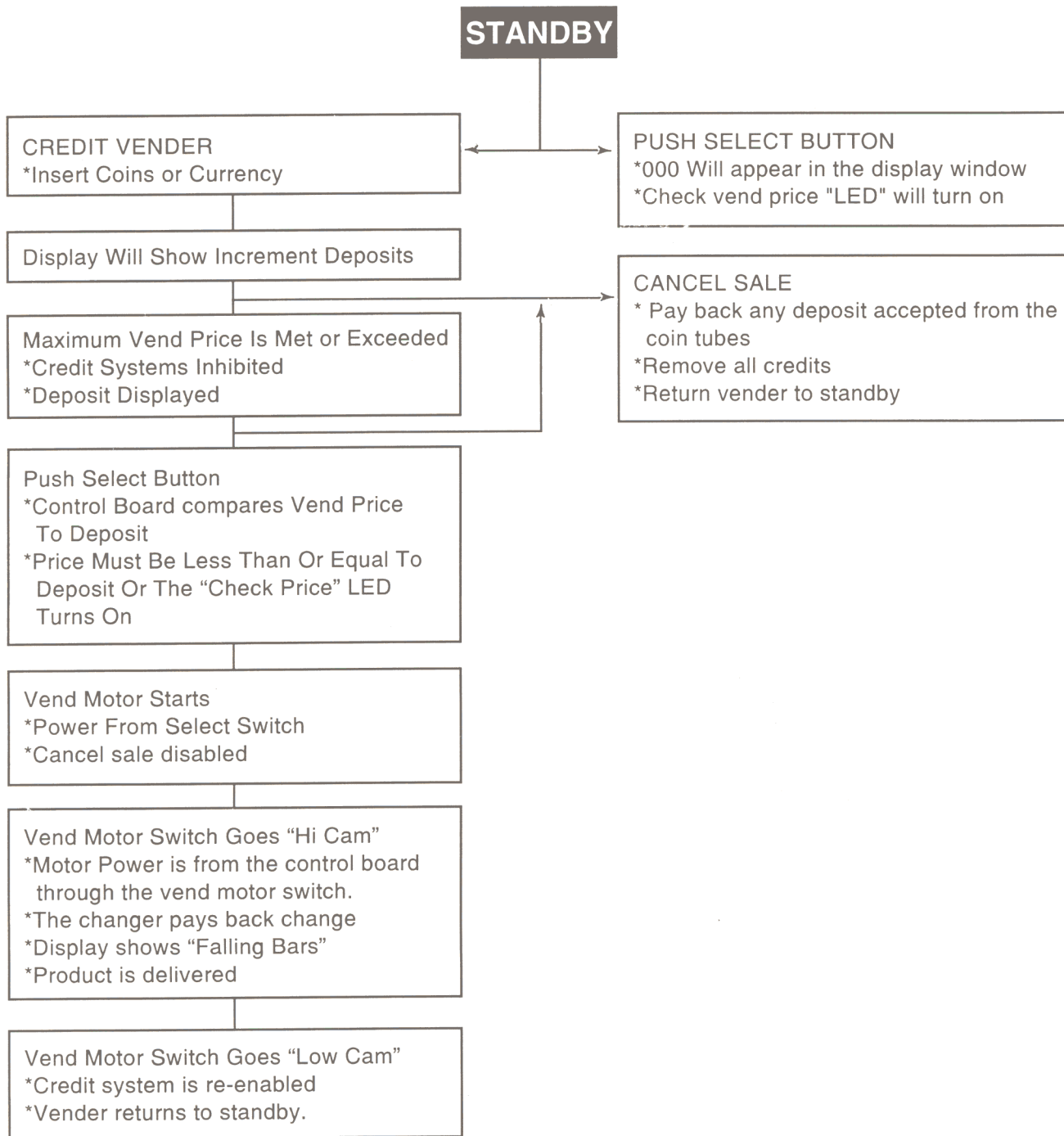

**MPC SERIES 1 SEQUENCE OF OPERATION
CONTROLLER STYLE CHANGERS
ESCROW TO SELECT & LAST BILL ESCROW (E-S1)**

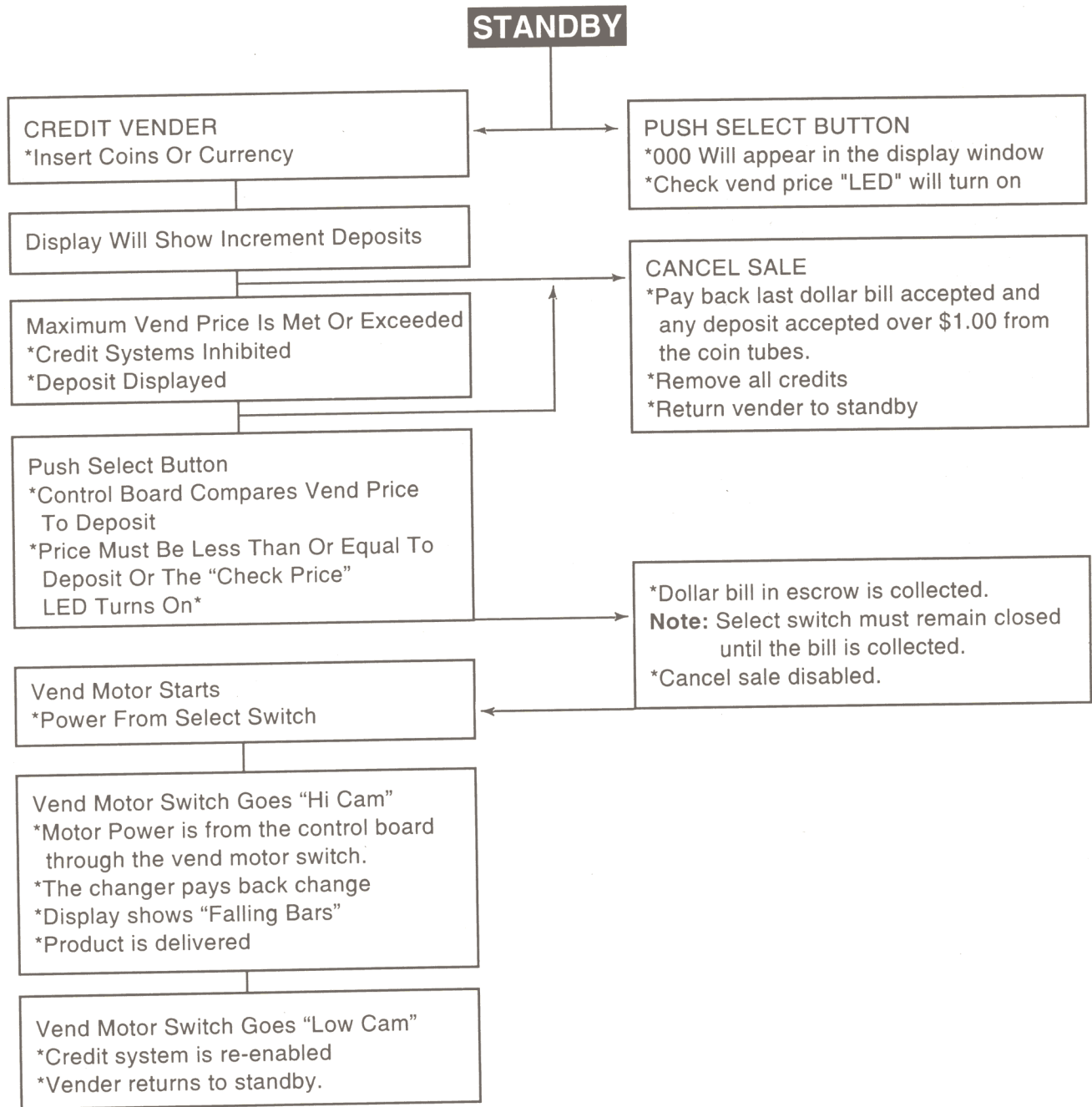

MPC SERIES 1 SEQUENCE OF OPERATION
SINGLE PRICE CHANGERS
ESCROW TO PRICE AND NO BILL ESCROW
 (ESCROW FUNCTION SET IN COIN CHANGER)

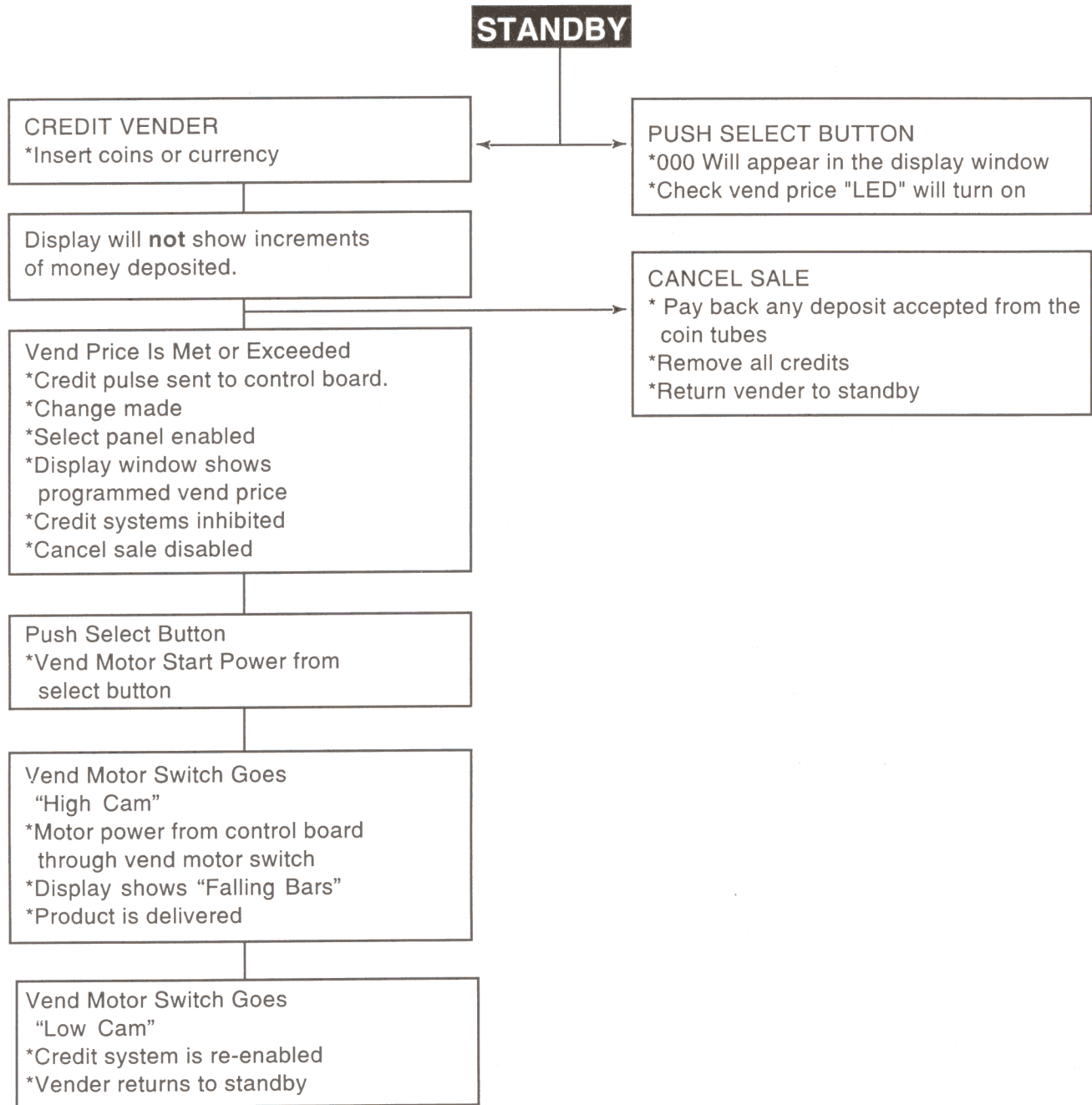

Vender Trouble Shooting

INDEX

Improper Display Reading	32, 33, 34 & 35
Coin and Currency Acceptance	35 & 36
Sold Out Lamp Operations	36
Select Button Operations	36 & 37
Motor Operations	38 & 39
Electrical Schematics	inserted after page 39

IMPROPER DISPLAY READING

PROBLEM: Flashing decimal point on the display.

SOLUTION:

1. Make sure the door switch is in the proper operating position.
2. Press the service switch, then push a select switch and read the prompt on the display.
3. If the display reads; Jan 1 2 3 4 5 6 7 8, then this indicates that all eight (8) motors are jammed or the polarity of the input power is wrong. On a blue board machine check the secondary wiring of transformer.
 - A. Check the polarity of the input power at both the 15-way connector and the 2-pin board connector. (Refer to the wiring diagram.)
 - B. If the problem is still not corrected, check the stack splice to ensure the proper connection. (Refer to the wiring diagram.)
 - C. If all the motors are jammed, check the wiring of the cam switches. (Refer to the wiring diagram.)
 - D. Check the 15-way connector to ensure the wiring is in the proper location.
 - E. Check the 6-pin plug on the board and make sure it is wired properly. (Refer to the wiring diagram.)
 - F. If the problem is still not solved, replace the MPC Series 1 control board.
4. If the display reads; Jan 1 or Jan 4 5 or Jan 5 6 7 8, etc. then this indicates a jammed motor or motors.
 - A. Check the motors to see if they are jammed.
 - B. Check the cam switch and cam switch wiring. (Refer to the wiring diagram.)
 - C. Check the wiring to the coil of the suspect motor. (Refer to the wiring diagram.)
 - D. Check the select panel switch associated with the suspect motor; make sure it is wired correctly. (Refer to the wiring diagram.)
 - E. Check the proper operation of the switch.
 - F. Replace the motor.
 - G. Check the polarity of the secondary of the transformer in a green board machine.

PROBLEM: Go into the service mode and s-t scrolls across the display.

SOLUTION:

1. Check the select switch wiring for proper terminating.
2. Check the 15-pin and 9-pin mini mate-n-loks for proper termination.
3. Check the 15-way connector for proper wire termination.
4. Check for a shorted motor.
5. Replace the MPC Series 1 control board.

PROBLEM: No decimal point on the display.

SOLUTION:

1. Power down the machine and power it back up.
2. Check the board power with a DVM at the 2-pin connector. the voltage should be 115V AC +/- 10%. (DVM - Digital Volt Meter)
 - A. If there is no power there, trace the AC power back to the stack plug to find the problem.
 - B. Wires no. 54 and 55 are crimped wrong. Look for 54 and 55 to be crossed.
 - C. Replace the MPC Series 1 control board.
3. The board has power in the 2-pin connector.
 - A. Unplug the machine.
 - B. Using the DVM across the primary of the transformer, read the resistance. If you have infinite resistance, replace the control board assembly.
 - C. If the resistance reads 70 ohms to 100 ohms across the primary, check across the secondary of the transformer. The resistance should be under 5 ohms. If you have infinite resistance, replace the board assembly.
 - D. If the board has power, check to see if the display cable is terminated in its proper location on both sides.
 - E. If the display cable is terminated correctly, check the display cable connector for bent pins and proper location. The button on the cable should be pointing in the direction of the board.
 - F. Replace the display cable.
 - G. Replace the display board.
 - H. Replace the MPC Series 1 control board.

PROBLEM: The machine will not go into the service mode.

SOLUTION:

1. Check the wiring on the door switch.
2. Check the termination of the 2-pin connector on the board.
3. Check for a bent pin at the 2-pin connector on the board.
4. Check the service switch termination.
5. Replace the MPC Series 1 control board.

PROBLEM: The machine will not advance through the menu.

SOLUTION:

1. Check the wiring on the door switch; high voltage side.(Refer to the wiring diagram.)
2. Check the wiring of the select switches.
3. Check the wiring of the 6-pin connector on the board.
4. Check the wiring on the 15 and 9-pin mini mate-n-lok connectors for proper termination of vend motors #1 and 2. (Refer to the wiring diagram.)
5. Check the select switch # 1 and 2 for proper termination.
6. Check for a motor shorted to neutral.
7. Check the wiring on motor # 1 and 2.
8. Replace the MPC Series 1 control board.

PROBLEM: The display board is not working.

SOLUTION:

1. Check the display cable to ensure proper termination.
2. Check the wires to ensure they are not broken.
3. Check the pins to ensure they are not bent.
4. Replace the display cable.
5. Replace the display board.
6. Replace the MPC Series 1 control board.

PROBLEM: Will not advance through the menu. (Coke only)

SOLUTION:

1. Check the wire no. 23 for proper termination.
2. Check motor # 1, 2, and 3 wiring for proper termination.
3. Check the wiring on the 15 and 9-pin mini mate-n-lok connectors for the proper termination of vend motors #1 and 2. (Refer to the wiring diagram.)

PROBLEM: Four (4) bars appear on the display and the machine will not vend or accept money.

SOLUTION:

1. Power down the machine and power it back up. The vender should return to stand-by.
2. One or more of the select switches are, or were, stuck in the activated position. Check the select switches for proper operation.
3. If a "DUMB MECH" is being used, the communication between the MPC and the mech may be non-functional. Replace the coin mech.
4. Replace the MPC Series 1 control board.

PROBLEM: Two bars, a decimal and two bars appear on the display.

SOLUTION:

1. A select button is broken, replace the broken select button.

PROBLEM: "St" stuck on display board, will not advance through the menu. Vender is new and has never been used.

SOLUTION:

NOTE: *Prior to initiating any repairs, a proper diagnosis of the problem is essential.*

1. Enter service mode and "St" appears on display.
2. Press buttons A and B simultaneously. If a numeric amount appears on the display board, check the wiring of the high voltage side of the door switch. If "St" remains on the display board with no numeric amount showing, follow steps 3 through 9.
3. Unplug the vender from the wall.
4. Position all motor switches on high side of the cam. This can be achieved by pushing on motor brake arm and turning cam.

5. **IMPORTANT:** if vender is loaded go to step 8.
6. Hold down on one of the sold out paddles.
7. Plug in vender.
8. Vender will re-configure itself and go back to proper operation.

PROBLEM: "St" stuck on display board. Vender has been on location and working fine.

SOLUTION:

1. Replace the MPC Series 1 control board.

COIN AND CURRENCY ACCEPTANCE

PROBLEM: A single price coin mech will not accept coins.

SOLUTION:

1. Check the price setting.
2. Replace the coin mech cable.
3. Replace the coin mech.
4. Check the empty circuit for proper wiring. If all sold-out lamps are on the coin mech is disabled.
5. Replace the MPC Series 1 control board.

PROBLEM: A controller coin mech will not accept coins.

SOLUTION:

1. Check the price setting.
2. Replace the coin mech cable.
3. Replace the coin mech.
4. Check the empty circuit for proper wiring. If all sold-out lamps are on the coin mech is disabled.
5. Replace the MPC Series 1 control board.

PROBLEM: The bill acceptor will not take a bill.

SOLUTION:

1. Make sure that the door switch is in the proper operating mode and terminated properly.
2. Replace the bill acceptor cable.
3. If a single price coin mech is being used, the note acceptor must be plugged into the coin mech.
4. Replace the interface cable.
5. Replace the bill acceptor.
6. Replace the coin mech.
7. Check that there is enough change in the coin mech to pay back a cancel sale for the maximum vend price and that the coin mech has been primed.

8. Check the empty circuit for proper wiring.
9. Replace the MPC Series 1 control board.

SOLD OUT LAMP OPERATIONS

PROBLEM: The sold-out lamp #8 is on when the column is full.

SOLUTION:

1. The sold-out switch # 8 is wired wrong.

PROBLEM: The sold-out lights are not operational.

SOLUTION:

1. Check the sold-out switch daisy chain for proper termination. Look for a loose wire or bad crimp in the stack plug.
2. Check the sold-out lamp wiring on the select panel. Check wire no. 2 leading to the sold-out # 8 neutral daisy chain.
3. Check the 12-way connectors leading to the stack and the door for proper termination.

PROBLEM: The MPC Board is not recognizing a sold-out condition.

SOLUTION:

1. Check the wiring on the 15 and 9-pin mini mate-n-lok connectors and the 12-pin mini mate-n-lok connector.
2. Check the wiring at the sold-out light on the select panel.
3. Replace the MPC Series 1 control board.

PROBLEM: *The sold-out lamp #1 corresponds to column #4.*

SOLUTION:

1. Check the wiring of both the 12-way connectors to ensure proper wiring.
2. Check the wiring of the sold-out switches to ensure proper termination.
3. Check wiring of the sold-out lamps to ensure proper location.

SELECT BUTTON OPERATIONS

PROBLEM: Push button # 3 and motor # 1 will run.

SOLUTION:

1. Check the wiring at the stack; the 15-way connector to ensure that motor #1 and #3 are in their proper location.
2. Check the wiring on the motor coil for the proper termination.
3. Check the wiring of the 15-way connector to the door for proper termination.

4. Check the switch wiring on the select panel, look for switch # 1 and # 3 to be wired incorrectly.
5. Check the 15-pin mini mate-n-lok to ensure proper termination.

PROBLEM: Push the No. 1 select switch, and get the scrolling bars, but the motor does not turn.

SOLUTION:

1. Check the wiring in the 15-way connectors.
2. Check the motor wiring.
3. Check for a jammed column.
4. Check the motor coil wiring.
5. Replace the MPC Series 1 control board.

PROBLEM: Push the No. 1 select switch, and the display shows "try another selection".

SOLUTION:

1. Check the sold-out light to see if it is on.
2. Check the 15 or 9-pin mini mate-n-lok to the board. (Refer to the wiring diagram.)
3. Check the sold-out switch wiring to ensure proper termination.
4. Check both the 12 and 15 way connectors for proper wiring.

PROBLEM: Push the no. 1 select switch and the display shows "Hold" or "push button 1".

SOLUTION:

1. Check the cam switch actuation.
2. Check the cam switch wiring and check the 15-way connector cam line.
3. Check the 6 way connector and the 15 and 9-pin mini mate-n-lok connector.
4. Check the motor coil wiring.
5. Check the motor shields to make sure they do not interfere with the motor operation.
6. Replace the MPC Series 1 control board.

PROBLEM: Select switch # 1 is not sequencing. (Coke only)

SOLUTION:

1. Check the wiring at the 6-way connector on the board.
2. Check the wiring at the 9-pin board connector.
3. Check the wiring at the first select switch.
4. Check the wiring at the 15-way connector to the stack.
5. Check the motor wiring.
6. Replace the MPC Series 1 control board.

MOTOR OPERATIONS

PROBLEM: The motors are free vending.

SOLUTION:

1. Check the motor wiring. (Refer to the wiring diagram.)
2. Check the cam switch wiring. (Refer to the wiring diagram.)
3. Replace the motors.
4. Check the motor brakes.
5. Check the vender price settings. A vend price of 0.00 is free vend.

PROBLEM: No motors will run.

SOLUTION:

1. Check the wiring at the 15-way connector. Check for loose crimps or broken wires on the stack side wire no. 4 or the select side wire no. 3.
2. Check to see if the cam power is properly installed in the correct position on the far left vend motor cam switch. It should be on the normally open contact. (Refer to the wiring diagram)
3. Check the motor coil wiring to ensure the neutral daisy chain is correct.
4. Check the stack connection for a loose crimp or broken wire.
5. Check the select panel wiring and the power to the select switches. Look for a broken wire or loose crimp.
6. Check the wiring at the 6 pin connector on the board. Look for a broken wire, loose crimp or improper termination.
7. Replace the board.

PROBLEM: Two motors run at the same time when one select switch is pressed.

SOLUTION:

1. Check the wiring between both motors. (Refer to the wiring diagram.)
2. Check the wiring at the select switch associated with the problem.

PROBLEM: Select # 4 motor does not run.

SOLUTION:

1. Check the wiring on the motor for a loose crimp or a broken wire.
2. Check both the 15-way connectors for proper wire termination.
3. Check select switch # 4 for proper wiring.
4. Check the 15-pin mini mate-n-lok for proper wiring.

PROBLEM: Motor # 2 is free vending. (Coke only)

SOLUTION:

1. Check the 6-way connector for proper termination.

PROBLEM: Flashing decimal display reads JAN 3 4 5 6 7 8. (Coke only)

SOLUTION:

1. Check to see if the motors are jammed.
2. Check the cam switch wiring for proper termination.
3. Check the motors # 1 and # 2 wiring for proper termination.

PROBLEM: Narrow column motors chatter.

SOLUTION:

1. Check motor brakes.
2. Check the wiring to the coils of the motors.
(Note that motors #6 and #7 are wired the opposite of all other motors.)
3. Side and front motor shields must be in place.
4. Replace the board.

PROBLEM: Motor #'s 1 and 2 can be pecked to run at the same time.

SOLUTION:

1. Check wiring between motors #1 and 2.
2. Check to see if a leaf spring was added to the inner door for the door switch.

PATENT NOTICE
THIS DEVICE IS MANUFACTURED UNDER ONE OR MORE OF THE FOLLOWING U.S. PATENTS:

- 3,115,274
- 3,463,355
- 3,484,989
- 3,702,164
- 3,270,917
- 4,019,650
- 3,367,536
- 4,036,400
- 4,036,621
- 4,264,000
- 4,298,138
- 4,705,176

HIGH LEVEL NOTE ACCEPTOR CONFIGURATION
USE 804 800 840 AT CABLE ASSEMBLY AND CONNECT TO P5 ON THE MPC CONTROLLER BOARD

LOW LEVEL NOTE ACCEPTOR CONFIGURATION
USE 804 800 850 AT CABLE ASSEMBLY AND CONNECT TO P6 ON THE MPC CONTROLLER BOARD

CONTROLLER COIN MECHANISM



SINGLE-PRICE COIN MECHANISM

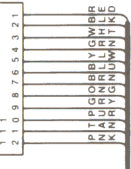
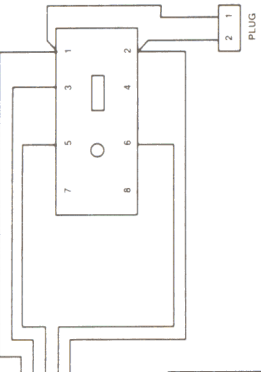

MPC CONTROLLER BOARD

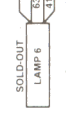
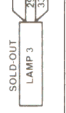
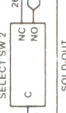

SLIMLINE INSTANT START LIGHTING



ON ALL CAPS & PLUGS PIN 1 IS LOCATED ADJACENT TO CORNER HAVING RIB

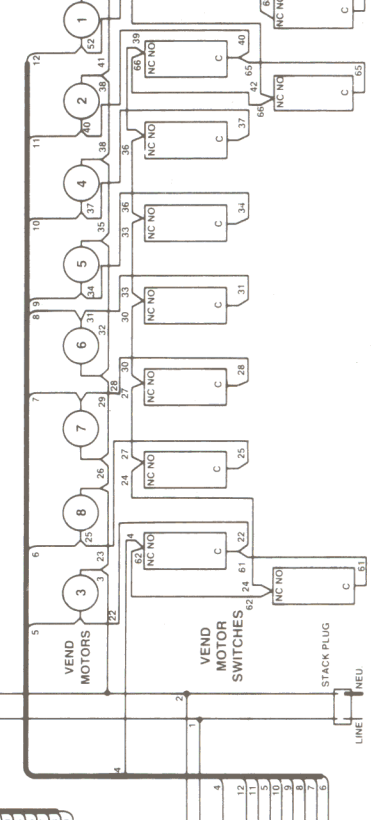
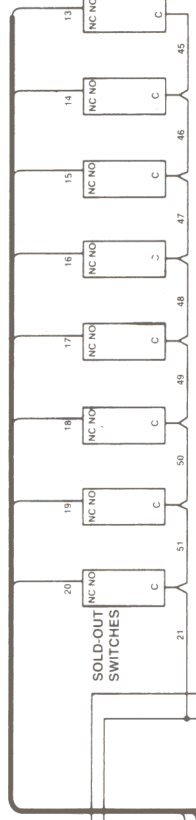
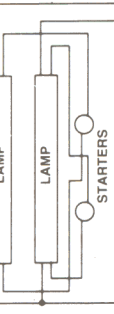

NOTE:

- MOTORS 1, 2, 3, 4, 5, 8
LINE CONNECTED ON LEFT SIDE
NEUTRAL CONNECTED ON RIGHT SIDE
- MOTORS 6 & 7
LINE CONNECTED ON RIGHT SIDE
NEUTRAL CONNECTED ON LEFT SIDE

MPC - WIRING DIAGRAM
8T (1X8)
903, 828, 640.01

Dixie-Narco
Electronics Division

SINGLE-PRICE COIN MECHANISM

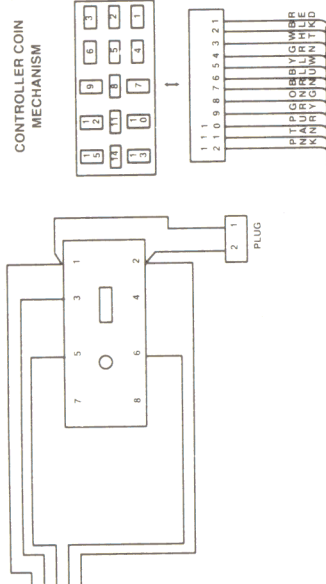

PATENT NOTICE
THIS DEVICE IS MANUFACTURED UNDER ONE OR MORE OF THE FOLLOWING U.S. PATENTS:

3,115,274	3,453,355	4,036,400
3,144,565	3,548,572	3,666,872
3,680,839	4,044,877	4,264,000
3,270,917	4,296,138	4,019,650
3,367,536	4,509,656	4,703,176

HIGH LEVEL NOTE ACCEPTOR CONFIGURATION
USE 804 902,840,01 CABLE ASSEMBLY AND CONNECT TO P9 ON THE MPC CONTROLLER BOARD

LOW LEVEL NOTE ACCEPTOR CONFIGURATION
USE 804 902,810,01 CABLE ASSEMBLY AND CONNECT TO P6 ON THE MPC CONTROLLER BOARD

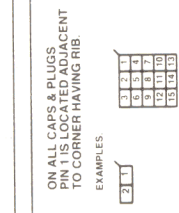
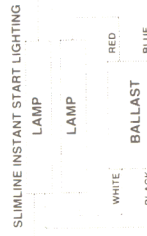
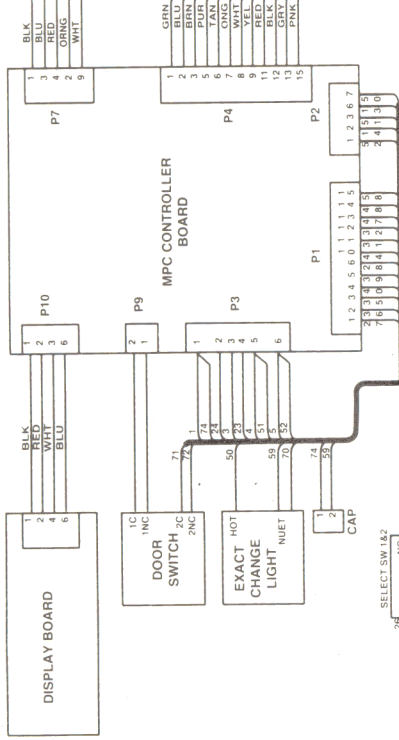

ON ALL CAPS & PLUGS
PIN 1 IS LOCATED ADJACENT
TO CORNER HAVING RIB.

EXAMPLES

1	2	1
4	3	4
9	8	7
13	11	10
13	14	13

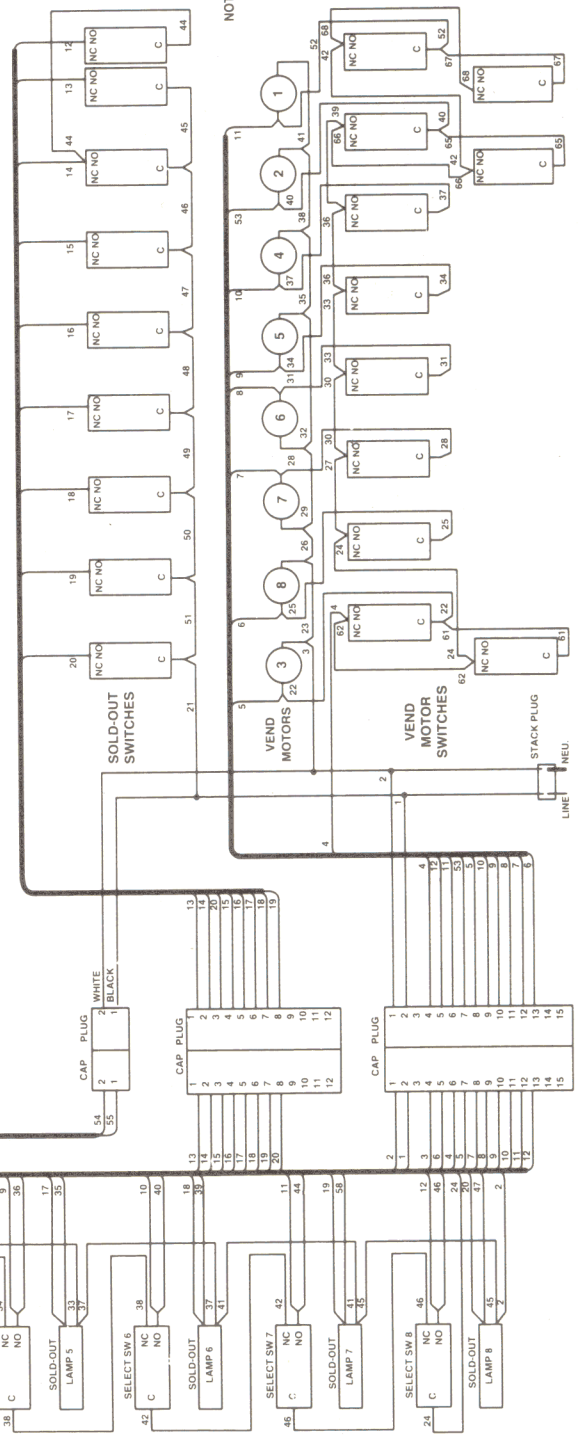

NOTE:

MOTORS 1, 2, 3, 4, 5 & 8
LINE CONNECTED ON LEFT SIDE
NEUTRAL CONNECTED ON RIGHT SIDE

MOTORS 6 & 7
NEUTRAL CONNECTED ON LEFT SIDE

MPC - WIRING DIAGRAM
77
903, 828, 660.01
Dixie-Narco
Electronics Division

SINGLE-PRICE COIN MECHANISM

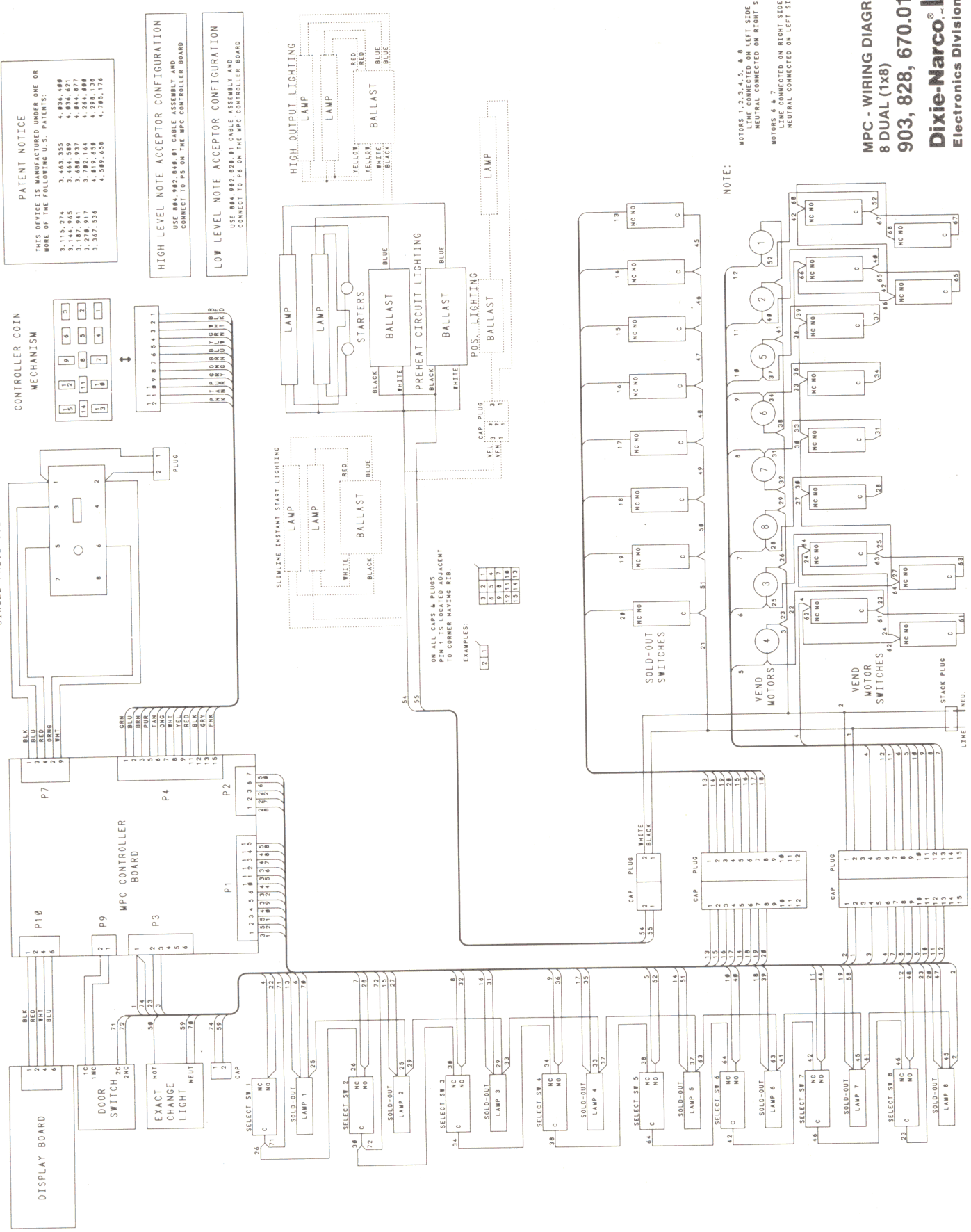

PATENT NOTICE
 THIS DEVICE IS MANUFACTURED UNDER ONE OR MORE OF THE FOLLOWING U. S. PATENTS:
 3,115,274 4,436,489
 3,463,355 4,436,489
 3,144,985 4,436,489
 3,464,589 4,436,489
 3,464,589 4,436,489
 3,464,589 4,436,489
 3,464,589 4,436,489
 3,464,589 4,436,489
 3,464,589 4,436,489
 3,464,589 4,436,489

HIGH LEVEL NOTE ACCEPTOR CONFIGURATION
 USE 884-982, 848 #1 CABLE ASSEMBLY AND CONNECT TO P5 ON THE MPC CONTROLLER BOARD

LOW LEVEL NOTE ACCEPTOR CONFIGURATION
 USE 884-982, 878 #1 CABLE ASSEMBLY AND CONNECT TO P6 ON THE MPC CONTROLLER BOARD

NOTE:

MOTORS 1, 2, 3, 4, 5, 6, 7
 LINE CONNECTED ON LEFT SIDE
 NEUTRAL CONNECTED ON RIGHT SIDE

MOTORS 4, 5, 7
 LINE CONNECTED ON RIGHT SIDE
 NEUTRAL CONNECTED ON LEFT SIDE

MPC - WIRING DIAGRAM
8 DUAL (1x8)
903, 828, 670.01
Dixie-Narco®
 Electronics Division

SINGLE-PRICE COIN MECHANISM

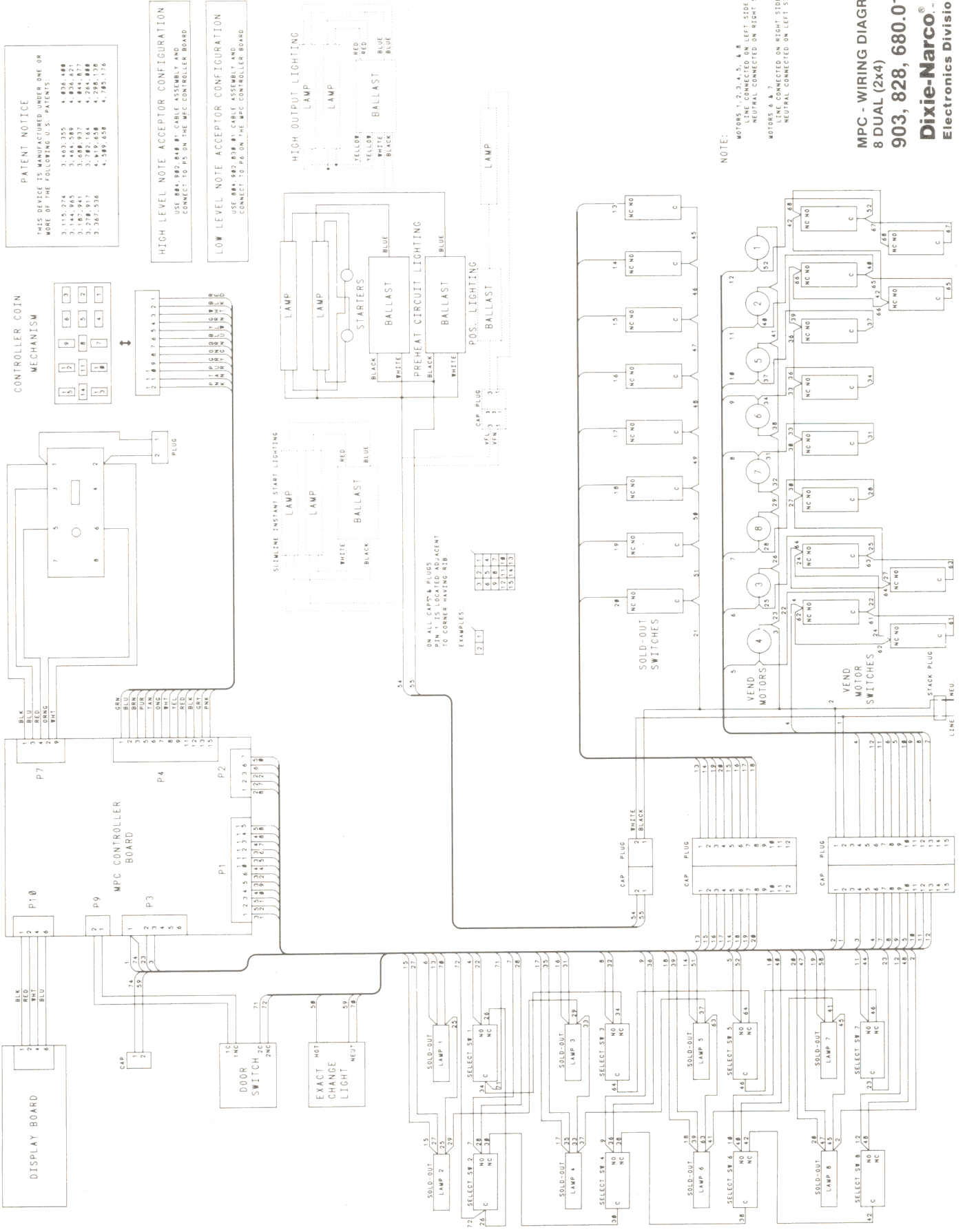

PATENT NOTICE
 THIS DEVICE IS MANUFACTURED UNDER ONE OR MORE OF THE FOLLOWING U.S. PATENTS:
 3,145,274
 3,145,275
 3,145,276
 3,145,277
 3,145,278
 3,145,279
 3,145,280
 3,145,281
 3,145,282
 3,145,283
 3,145,284
 3,145,285
 3,145,286
 3,145,287
 3,145,288
 3,145,289
 3,145,290
 3,145,291
 3,145,292
 3,145,293
 3,145,294
 3,145,295
 3,145,296
 3,145,297
 3,145,298
 3,145,299
 3,145,300
 3,145,301
 3,145,302
 3,145,303
 3,145,304
 3,145,305
 3,145,306
 3,145,307
 3,145,308
 3,145,309
 3,145,310
 3,145,311
 3,145,312
 3,145,313
 3,145,314
 3,145,315
 3,145,316
 3,145,317
 3,145,318
 3,145,319
 3,145,320
 3,145,321
 3,145,322
 3,145,323
 3,145,324
 3,145,325
 3,145,326
 3,145,327
 3,145,328
 3,145,329
 3,145,330
 3,145,331
 3,145,332
 3,145,333
 3,145,334
 3,145,335
 3,145,336
 3,145,337
 3,145,338
 3,145,339
 3,145,340
 3,145,341
 3,145,342
 3,145,343
 3,145,344
 3,145,345
 3,145,346
 3,145,347
 3,145,348
 3,145,349
 3,145,350
 3,145,351
 3,145,352
 3,145,353
 3,145,354
 3,145,355
 3,145,356
 3,145,357
 3,145,358
 3,145,359
 3,145,360
 3,145,361
 3,145,362
 3,145,363
 3,145,364
 3,145,365
 3,145,366
 3,145,367
 3,145,368
 3,145,369
 3,145,370
 3,145,371
 3,145,372
 3,145,373
 3,145,374
 3,145,375
 3,145,376
 3,145,377
 3,145,378
 3,145,379
 3,145,380
 3,145,381
 3,145,382
 3,145,383
 3,145,384
 3,145,385
 3,145,386
 3,145,387
 3,145,388
 3,145,389
 3,145,390
 3,145,391
 3,145,392
 3,145,393
 3,145,394
 3,145,395
 3,145,396
 3,145,397
 3,145,398
 3,145,399
 3,145,400
 3,145,401
 3,145,402
 3,145,403
 3,145,404
 3,145,405
 3,145,406
 3,145,407
 3,145,408
 3,145,409
 3,145,410
 3,145,411
 3,145,412
 3,145,413
 3,145,414
 3,145,415
 3,145,416
 3,145,417
 3,145,418
 3,145,419
 3,145,420
 3,145,421
 3,145,422
 3,145,423
 3,145,424
 3,145,425
 3,145,426
 3,145,427
 3,145,428
 3,145,429
 3,145,430
 3,145,431
 3,145,432
 3,145,433
 3,145,434
 3,145,435
 3,145,436
 3,145,437
 3,145,438
 3,145,439
 3,145,440
 3,145,441
 3,145,442
 3,145,443
 3,145,444
 3,145,445
 3,145,446
 3,145,447
 3,145,448
 3,145,449
 3,145,450
 3,145,451
 3,145,452
 3,145,453
 3,145,454
 3,145,455
 3,145,456
 3,145,457
 3,145,458
 3,145,459
 3,145,460
 3,145,461
 3,145,462
 3,145,463
 3,145,464
 3,145,465
 3,145,466
 3,145,467
 3,145,468
 3,145,469
 3,145,470
 3,145,471
 3,145,472
 3,145,473
 3,145,474
 3,145,475
 3,145,476
 3,145,477
 3,145,478
 3,145,479
 3,145,480
 3,145,481
 3,145,482
 3,145,483
 3,145,484
 3,145,485
 3,145,486
 3,145,487
 3,145,488
 3,145,489
 3,145,490
 3,145,491
 3,145,492
 3,145,493
 3,145,494
 3,145,495
 3,145,496
 3,145,497
 3,145,498
 3,145,499
 3,145,500

HIGH LEVEL NOTE ACCEPTOR CONFIGURATION
 USE 884-982, 848 #1 CABLE ASSEMBLY AND CONNECT TO P5 ON THE MPC CONTROLLER BOARD

LOW LEVEL NOTE ACCEPTOR CONFIGURATION
 USE 884-982, 838 #1 CABLE ASSEMBLY AND CONNECT TO P6 ON THE MPC CONTROLLER BOARD

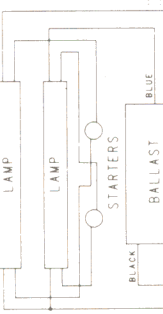

ON ALL CAPS & PLUGS PIN IS LOCATED ADJACENT TO CORNER MARKING RIDG

EXAMPLES:
 1 2 1 1
 6 5 4
 9 8 7
 12 11 10
 15 14 13

NOTE:
 MOTORS 1, 2, 3, 4, 5, & 8
 LINE CONNECTED ON LEFT SIDE
 NEUTRAL CONNECTED ON RIGHT SIDE
 MOTORS 6 & 7
 LINE CONNECTED ON RIGHT SIDE
 NEUTRAL CONNECTED ON LEFT SIDE

MPC - WIRING DIAGRAM
8 DUAL (2x4)
903, 828, 680.01
Dixie-Narco®
 Electronics Division

General Maintenance

WHAT TO CLEAN

CABINET

Wash the vender exterior with either soap and warm water or a good detergent and warm water.

Wash all plastic parts with a mild soap and warm water.

NOTE: *This includes the sign face.*

The vender should be waxed often with a good grade of automobile wax.

Any corrosion inside the vender should be removed with fine steel wool and the area should be painted with aluminum paint. Keep the condenser clean.

COIN ACCEPTOR

Follow the Coin Acceptor Manufacturers instructions.

REFRIGERATION CONDENSER

Check the condenser periodically for dirt or lint build up.

Clean the build up with a brush, vacuum, or blow the dirt out of the condenser.

Ensure nothing obstructs air intake at bottom of main door.

Check the rear of the cabinet periodically to ensure the exhaust is not blocked by foreign objects.

WHEN AND WHAT TO LUBRICATE

Every Six Months

(or as needed)

MAIN DOOR

1. Lock bolt and nut retainer
2. Hinge pivot points

EXAMPLE OF LUBRICANTS

Mechanics Friend
Mechanics Friend

INNER DOOR

1. Hinge pivot points

Mechanics Friend

Every Year

(or as needed)

INNER DOOR

1. Door gasket

Petroleum Jelly

THINGS TO ADJUST

TEMPERATURE CONTROL

This is a "Constant Cut In" type of control which has two (2) adjustments:

They are:

1. The temperature control knob on the outside of the temperature control box.
2. The inside range screws - see below for details.

NOTE: *The differential screw located between the terminals of the control is sealed and MUST NOT BE CHANGED.*

AS TO #1 ADJUSTMENT:

(Outside Range). See Fig 1.

The temperature control knob is set in an approximate neutral position. It can be used to make the **cut out** temperature colder by turning the knob **clockwise**, or to make the **cut out** temperature warmer by turning the knob **counter clockwise**. When the knob is used the **cut in** temperature (which governs the defrost) remains **constant**.

AS TO #2 ADJUSTMENT:

(Inside Range). See Fig. 2.

On the Cutler Hammer temperature control there are two (2) screws provided, one (1) for **the cut in temperature** and one (1) for **the cut out temperature**, both must be adjusted for altitude corrections. For temperature adjustment, turn screws **clockwise** for colder and **counter clockwise** for warmer. When adjusting for temperature **DO NOT TURN** more than 1/8 of a turn at a time. Let the machine run over night before making further adjustment.

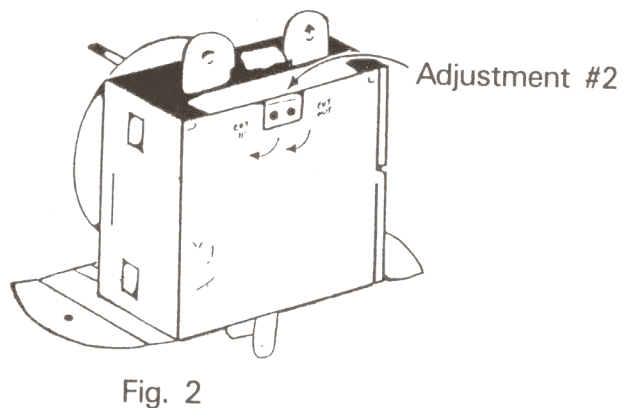
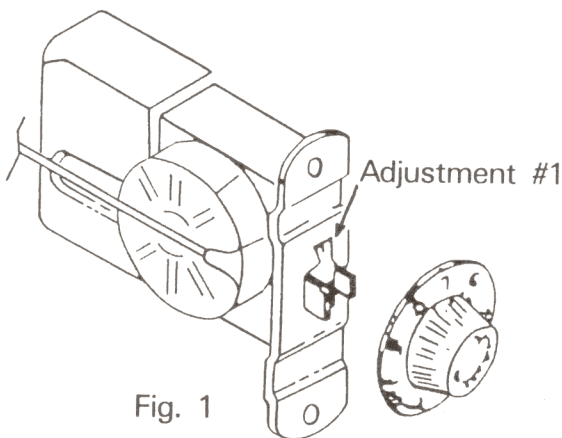

TEMPERATURE CONTROL ALTITUDE ADJUSTMENT

The Control is factory set at an altitude of 500 ft. For higher altitudes, the control should be adjusted to prevent freeze-up of product. Adjust the inside range screws as follows:

<u>ALTITUDE FEET:</u>	<u>Cutler-Hammar 9531N272</u> <u>BOTH SCREWS COUNTER-CLOCKWISE</u>
2000	1/8 TURN
4000	1/4 TURN
6000	1/2 TURN
8000	5/8 TURN

Refrigeration Parts and Functions

MECHANICAL PARTS

COMPRESSOR MOTOR

The compressor motor (sealed in the compressor housing) drives the compressor with a shaft that is shared by both parts. It is started by the temperature control switch, the starting relay and the thermal overload switch. It is stopped by the temperature control switch, and, if it gets overloaded, by the thermal overload switch.

COMPRESSOR

The compressor (sealed in the compressor housing) draws cold, low pressure freon gas from the evaporator and pumps hot, high pressure freon gas out to the condenser.

CONDENSER

The condenser, located in the base of the vender, at the front, takes heat out of the hot, high pressure gas that comes from the compressor. The gas loses heat as it goes through the condenser coils, and changes into a liquid because it is still under pressure.

CONDENSER FAN

The condenser fan (between the condenser and the compressor motor), first draws air from the outside of the vender through the condenser. This air takes heat from the condenser first and then is blown over the compressor housing from which it also takes heat before going back outside of the vender. The condenser fan runs when the compressor motor runs.

FILTER/DRYER

The filter/dryer is in the liquid line between the condenser and the capillary tube. This dryer filters out any foreign particulate matter and also contains a desiccant to absorb any moisture that may be present in the system.

CAPILLARY TUBE

The capillary tube (between the condenser and the evaporator in the refrigerant line) has a very small inside diameter, and serves to control the refrigerant flow from the condenser into the evaporator.

EVAPORATOR

The evaporator (in the vender cabinet) takes heat from the air in the vender cabinet and gives this heat to the liquid refrigerant. The liquid refrigerant is evaporated (boiled off) as a gas, and the gas is drawn out by the compressor.

EVAPORATOR FAN

The evaporator fan draws warm air from around the cans or bottles in the cooling com-

partment and blows it across the evaporator. As the air goes across the evaporator, it gives up heat to the evaporator, then goes back to the cans or bottles, and takes heat from them. This fan runs continuously when the vender is plugged in.

CONDENSATE PAN

The condensate pan (located in the compressor compartment) collects the water which runs from the evaporator. The water is evaporated into the surrounding air by means of soakers. The soakers extend down into the pan to absorb the water. Exposure to the surrounding air vaporizes the water in the soakers.

ELECTRICAL PARTS

TEMPERATURE CONTROL

The temperature control is the part that is made up of a control bulb connected by a small metal tube to a bellows. The control bulb is in a slot in the evaporator fan housing. The bellows and a switch known as the temperature control switch, are in the temperature control box which is fastened to the right side inside the vender.

The control bulb and the bellows have a vapor in them. When the temperature of the vapor in the bulb rises, it builds up pressure in the bellows tube. This pushes the bellows out. When the control bulb is cool, the vapor shrinks back, and the bellows pulls in. These movements, of the bellows, work the switch - called the temperature control switch - closing it when the bulb is heated and opening it when the bulb is cooled.

The contacts of the temperature control switch are in the compressor motor's running and starting circuits. They are also in the condenser fan motor circuit.

When the cabinet temperature gets up to the cut-on setting, the temperature control switch closes in the compressor motor's starting and running circuits and in the condenser fan circuit. When the cabinet temperature gets down to the cut-off setting, the temperature control switch opens in these circuits.

CAUTION: *To adjust the temperature control see "Things to Adjust," page 41.*

THERMAL OVERLOAD ASSEMBLY

The thermal overload is a temperature activated switch that interrupts power to the compressor when excessive temperatures occur. This switch protects the compressor from the damage that will occur if the compressor continues to operate under adverse conditions. The overload also opens under abnormally high amp draws, protecting the motor windings from damage. Frequent overload trips may lead to warm product and be the first indication of a dirty condenser or other refrigeration related problems that require attention.

STARTING RELAY

The starting relay is a device that connects the start winding of the compressor during start up. The additional winding (start) helps the compressor motor come up to speed. Once it reaches speed the starting relay disconnects the start winding from the circuit.

ELECTRICAL OPERATION

WHAT DOES IT

WHAT HAPPENS

WHEN THE VENDER TEMPERATURE GETS UP TO THE CUT-ON SETTING

The temperature control switch

Closes the run winding circuit of the compressor motor.

Closes the start relay coil circuit.

Closes in the condenser fan motor circuit.

THE HEAVY CURRENT, DRAWN BY THE RUN WINDING, ALSO FLOWS IN THE START RELAY COIL, AND:

The start relay coil

Closes the start relay contacts and completes the start winding circuit of the compressor motor.

WHEN THE COMPRESSOR MOTOR GETS UP TO SPEED

The spring in the relay

Pushes the start relay contacts apart because

The start relay coil

No longer gets enough current to hold the contacts closed,

The start relay contacts

Open in the start winding circuit of the compressor motor.

IF THE COMPRESSOR MOTOR DRAWS TOO MUCH CURRENT AND CAUSES THE THERMAL OVERLOAD ASSEMBLY TO GET TOO WARM

The thermal overload switch

Opens the run winding circuit and disconnects the compressor motor.

WHEN THE THERMAL OVERLOAD ASSEMBLY COOLS DOWN AGAIN

The thermal overload switch

Closes the run winding circuit and the start relay coil circuit of the compressor motor.

WHEN THE VENDER TEMPERATURE GETS DOWN TO THE CUT-OFF SETTING

The temperature control switch

Opens in the run winding circuit of the compressor motor.

Opens in the starting relay coil circuit.

ELECTRIC CIRCUITS AND CIRCUIT DIAGRAMS

CONDENSER FAN CIRCUIT

SWITCHES IN THE WIRING

Temperature control switch

WHAT THE SWITCHES DO

Turn the condenser fan motor on and off

WHAT MAKES THE SWITCHES WORK

The temperature in the vender has come up to the cut-on point (or gotten down to the cut-off point) set on the temperature control.

COMPRESSOR MOTOR RUN WINDING CIRCUIT

SWITCHES IN THE WIRING

1. Temperature control switch

2. Start Relay

3. Thermal overload switch

WHAT THE SWITCHES DO

1. Turns the compressor motor on and off.

2. Turns the start windings on and off.

3. Turns the run windings of the compressor motor on.

WHAT MAKES THE SWITCHES WORK

1. The temperature in the vender has come up to the cut on point (or got down to the cut off point) set on the temperature control switch.

2. The presence or absence of heavy current switches the relay which energizes or de-energizes the start windings.

3. Current drawn by the motor or heat from the compressor can raise the temperature of the thermal overload switch cut off. Which removes power from the compressor.

REFRIGERATION CIRCUIT DIAGRAMS

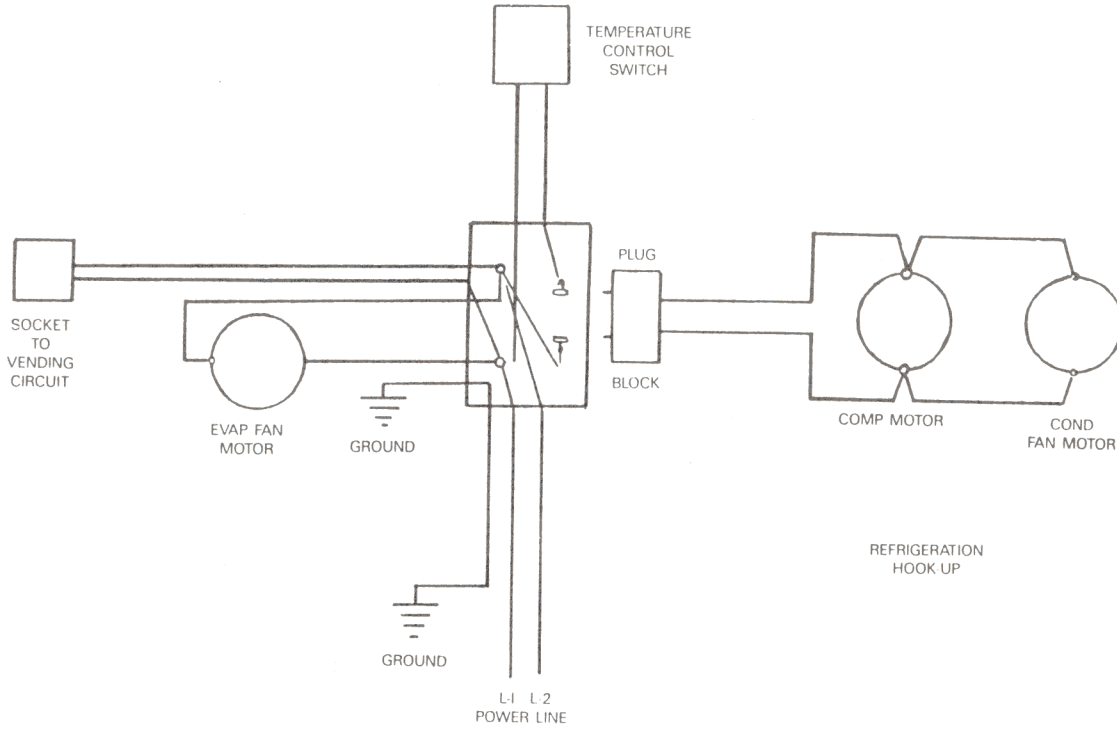

Techumseh

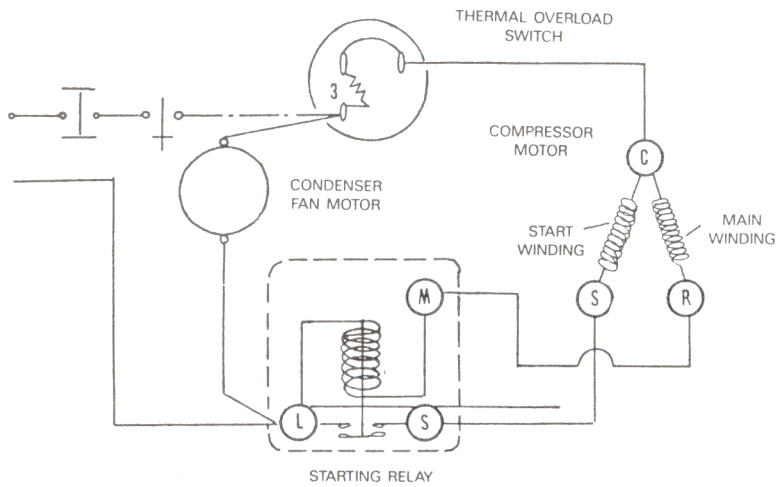

Embraco

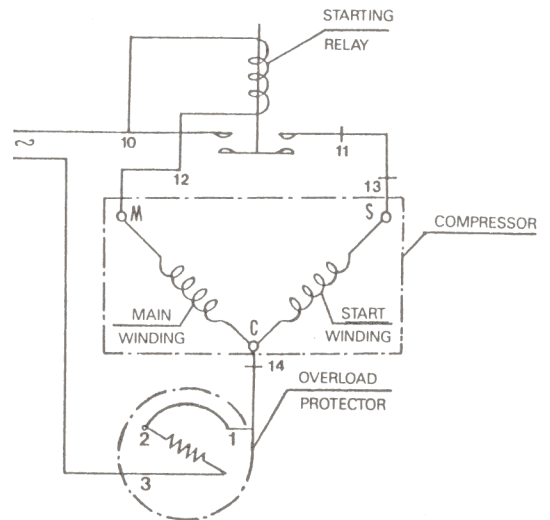

Refrigeration Cycle

WHAT DOES IT

The rising temperature in the venter

The charge in the control bulb

The bellows

The temperature control switch

The compressor motor

The condenser fan motor

The compressor

The condenser

The cooled gas

More hot gas coming from the compressor

The capillary tube

The evaporator

The liquid refrigerant

WHAT HAPPENS

Warms the temperature control bulb and the charge in it

Expands in the control tube and stretches the temperature control bellows.

Activates the temperature control switch

Turns the compressor motor on. Turns the condenser fan motor on.

Drives the compressor.

Drives the condenser fan. Draws air through the condenser, cooling it and pushes air over the compressor, cooling it.

Draws low pressure refrigerant gas from the evaporator, compresses the gas, and pumps it to the condenser.

Takes the heat out of the high pressure refrigerant gas.

Condenses into liquid refrigerant.

Pushes the liquid refrigerant into the capillary tube.

Controls the flow of liquid refrigerant into the evaporator.

(Where the pressure is kept low by the suction of the compressor) transfers heat from the air to liquid refrigerant.

Changes into gas at low pressure and is drawn into the compressor.

WHAT DOES IT

The falling temperature in the vender

The charge in the control bulb

The bellows

The temperature control switch

The compressor

The condenser fan motor

WHAT HAPPENS

Cools the temperature control bulb and the charge in it to a predetermined temperature.

Shrinks, and lets the temperature control bellows pull back.

Move, and open the temperature control switch.

Turns the compressor motor off.
Turns the condenser fan motor off.

Stops.

Stops.

(With the vender "Plugged In" the evaporator fan motor runs constantly)

HOW TO TAKE CARE OF THE REFRIGERATION SYSTEM

WHAT TO CLEAN

Carefully clean dirt and lint from the condenser with a brush, vacuum cleaner or compressed air.

WHEN AND WHAT TO LUBRICATE

To refrigeration system is hermetically sealed and does not have to be oiled or greased. Enough oil is put into the condenser and evaporator fan motors when they are manufactured to last the life time of the component.

CORRECTING TROUBLES

When the refrigeration system is not working properly, refer to the section called "Correcting Common Refrigeration Troubles" on the following pages. Find your trouble and see what the possible causes are. When you have found the cause of the trouble, either make the adjustment, repair the part, or put a new part in, whatever is needed. This table does not list all the possible causes of refrigeration troubles - but it does have all the common causes. If your vender has a trouble that is not shown on the chart, or the trouble is not the result of one of the causes shown on the chart,, study the section on "How the Refrigeration Mechanism Works" and you may be able to find out what is wrong and fix it.

Refrigeration Trouble Shooting

PRODUCT HOT:

Compressor will not run.

51

Compressor starts but will not keep running.

52

PRODUCT COLD BUT NOT COLD ENOUGH:

Compressor runs but won't cool product.

53 & 54

PRODUCT TOO COLD OR FROZEN:

Compressor runs too long or continuously.

54

NOISY REFRIGERATION UNIT:

Possible causes.

55

Symptom: **PRODUCT HOT**

Possible Cause: **Compressor will not run.**

WHAT TO CHECK

- | | |
|---|-------------------------------------|
| 1. Is the vender plugged in?
YES | NO , plug it in. |
| 2. Is the compressor power cord plugged in?
YES | NO , plug it in. |
| 3. Is the temperature control on?
YES | NO , turn it on. |
| 4. Is the circuit breaker or fuse correct?
YES | NO , replace or reset. |
| 5. Is there power at the wall outlet?
YES | NO , consult an electrician. |
| 6. Is the vender power cord good?
YES | NO , replace. |
| 7. Is the compressor power cord good?
YES | NO , replace. |
| 8. Is the temperature control bulb located properly?
YES | NO , correct. |
| 9. Is the temperature control good?
YES | NO , replace. |
| 10. Is the thermal overload good?
YES | NO , replace. |
| 11. Is the start relay good?
YES | NO , replace. |
| 12. Is the compressor good?
YES | NO , replace. |
| 13. Consult the Dixie-Narco Factory Service
1-800-688-9090 or your Dixie-Narco
Representative. NOTE: <i>Have the vender
Model & Serial number available.</i> | |

Symptom: **PRODUCT HOT**

Possible Cause: **Compressor starts, but will not keep running.**

WHAT TO CHECK

- | | |
|---|--|
| 1. Is the temperature control knob set on its highest setting?
YES | NO , adjust the knob to a higher setting. |
| 2. Is the voltage supply between 103V and 127V?
YES | NO , consult the power company. |
| 3. Is the condenser clear of obstructions?
YES | NO , clear or clean. |
| 4. Is the condenser fan blade turning?
YES | NO , free the obstruction or replace the blade if needed. |
| 5. Is the condenser fan motor good?
YES | NO , replace. |
| 6. Is the temperature control good?
YES | NO , replace. |
| 7. Is the tube from the compressor to condenser free of kinks?
YES | NO , repair or replace. |
| 8. Is the capillary tube free of kinks?
YES | NO , replace. |
| 9. Is the thermal overload good?
YES | NO , replace. |
| 10. Is the start relay good?
YES | NO , replace. |
| 11. Consult the Dixie-Narco Factory Service 1-800-688-9090 or your Dixie-Narco Representative. NOTE: <i>Have the vender Model & Serial number available.</i> | |

Symptom: PRODUCT COLD BUT NOT COLD ENOUGH

Possible Cause: **Compressor runs, but won't cool product.**

WHAT TO CHECK

- | | |
|---|---|
| 1. Is the temperature control knob set properly?
YES | NO , set properly. |
| 2. Is the voltage supply between 103V and 127V?
YES | NO , consult the power company. |
| 3. Is the temperature control probe located properly?
YES | NO , correct. |
| 4. Is the condenser clear of obstruction?
YES | NO , clear, clean, or space the vender properly. |
| 5. Is the evaporator fan free of obstruction?
YES | NO , free any obstruction or replace. |
| 6. Is the condenser fan free of obstruction?
YES | NO , free any obstruction or replace. |
| 7. Is the evaporator free of ice?
YES | NO , defrost & check the following: gasket seal, port door seal, refrigerant charge. |
| 8. Is the temperature control good?
YES | NO , replace. |
| 9. Is the evaporator fan good?
YES | NO , replace. |
| 10. Is the condenser fan motor good?
YES | NO , replace. |
| 11. Is the refrigerant tubing free of kinks?
YES | NO , repair or replace. |
| 12. Is the overload good?
YES | NO , replace. |
| 13. Is the start relay good?
YES | NO , replace. |

14. Is there refrigerant in the system?
YES

NO, charge system and check for leaks.

13. Consult the Dixie-Narco Factory Service 1-800-688-9090 or your Dixie-Narco Representative. **NOTE:** *Have the vender Model & Serial number available.*

Symptom: **PRODUCT TOO COLD OR FROZEN**

Possible Cause: **Compressor runs too long or continuously**

WHAT TO CHECK

1. Is the temperature control knob set properly?
YES

NO, set properly.

2. Is the temperature control bulb located properly?
YES

NO, correct.

3. Is the temperature control good?
YES

NO, replace.

4. Does the evaporator frost over completely while the system is running?
YES

NO, check for leaks or low charge.

5. Consult the Dixie-Narco Factory Service 1-800-688-9090 or your Dixie-Narco Representative. **NOTE:** *Have the vender Model & Serial number available.*

Symptom: NOISY REFRIGERATION UNIT

POSSIBLE CAUSES

- | | |
|--|---|
| 1. Are refrigerant lines free of contact with surfaces?
YES | NO , correct. |
| 2. Is the condenser fan blade hitting?
YES | NO , free any obstructions or replace the blade if needed. |
| 3. Is the evaporator fan blade hitting?
YES | NO , free any obstructions or replace the blade if needed. |
| 4. Is compressor noisy?
YES | NO , replace |
| 5. Consult the Dixie-Narco Factory Service 1-800-688-9090 or your Dixie-Narco Representative. NOTE: <i>Have the vender Model & Serial number available.</i> | |

IF REFRIGERATION TROUBLE SHOOTING PROCEDURES FAIL,
CONSULT THE DIXIE-NARCO FACTORY SERVICE
or YOUR DIXIE-NARCO REPRESENTATIVE

1-800-688-9090
1-803-266-5000

NOTE: Have the vender model # and serial # available.

Manual # 903, 902, 080.01