

# *Technical* Manual

## **Pepsi-Cola High Visibility Vender**

For HT2 Venders Produced Beginning Production Run 6730BZ

For HT3 Venders Produced Beginning Production Run 6757DZ



Manufactured by

**Dixie-Narco, Inc.**

Dixie-Narco, Inc.  
P.O. Drawer 719  
Williston, SC 29853-0719  
888-353-9722  
803-266-0700  
fax: 803-266-4747  
Visit us on the web: [www.dixienarco.com](http://www.dixienarco.com)

# Table of Contents

<b>GENERAL INFORMATION</b>	
Application.....	3
Vender Safety Precautions.....	3
Product Identification.....	3
Physical Characteristics.....	3
<b>A INSTALLATION &amp; SETUP</b>	
Unpacking the Vender.....	4
Electric Power Requirements.....	4
Ground the Vender.....	4
Pepsi Electronic Door Lock.....	4 - 5
Placing the Vender on Location.....	5
Level the Vender.....	5
Space the Vender.....	5
Coin Changers and Other Accessories.....	6
Loading the Change Tubes.....	6
Loading Product.....	6
Initial Loading.....	6
<b>B PROGRAMMING</b>	
Historical Data.....	7
Interval Data – Resettable Data.....	8
Set Price.....	8
Cash Settings.....	8
User Menu.....	10 - 17
Diagnostics Menu.....	17 – 18
Quick Reference Prompts.....	19
Default Space-To-Sales Setting.....	20
Set Vender Type.....	21
<b>C GENERAL MAINTENANCE</b>	
Power.....	22
Cleaning.....	22
Refrigeration Condenser.....	22
Coin Acceptor.....	22
Lubricating the Vender.....	22
EPROM Replacement.....	23
<b>D MAJOR COMPONENT DESCRIPTION</b>	
Electrical.....	24
Refrigeration.....	24
HT2 Universal Controller.....	25
HT2 Machine Controller.....	26
HT3 Control Board.....	27
<b>E TROUBLESHOOTING FLOWCHARTS</b>	
All Coins are Rejected.....	28
All Bills are Rejected.....	29
Incorrect Change Dispensed.....	30
Selection Will Not Vend.....	31
Ice / Frost on Evaporator.....	32
Compressor Runs Continuously.....	32
Compressor Will Not Start.....	33
Machine Not Cooling.....	34
Can't Enter the Menu or Diagnostics.....	35
Lights Are Not On.....	36
One or More Motors Run When Main Door is Closed.....	37
Sold Out Switch.....	38
The Display is Dead.....	39
Can't Read the Display.....	40

# Table of Contents

## **F WIRING DIAGRAMS AND SCHEMATICS**

Figure 1 – HT2 Wiring Diagram .....	41
Figure 2 – HT3 Wiring Diagram .....	42
Figure 3 – Compressor Wiring Diagram .....	43
Figure 4 – HT3 Choke / Relay Plate Assy. ....	44
Figure 5 – HT2 Schaffner Fitter / Relay Plate Assy.....	45

## **G PARTS LIST**

MAIN DOOR EXTERIOR .....	46 - 47
MAIN DOOR INTERIOR (A) .....	48 - 49
MAIN DOOR INTERIOR (B) .....	50 - 51
SELECT PANEL .....	52 - 53
T8 LIGHTING .....	54 - 55
ELECTRONIC COMPONENTS .....	56 - 57
INNER DOOR.....	58 - 59
HARNESSING.....	60 - 63
CABINET AND VEND MECHANISM (SECTION ONE).....	64 - 65
CABINET AND VEND MECHANISM (SECTION TWO) .....	66 - 67
CABINET AND VEND MECHANISM (SECTION THREE) .....	68 - 69
CABINET INTERIOR .....	70 - 71
HINGES AND ROLLER ASSY.....	72 - 73
REFRIGERATION SYSTEM (SECTION ONE).....	74 - 75
REFRIGERATION SYSTEM (SECTION TWO) .....	76 - 77
MISCELLANEOUS LABELS.....	78
SIGNS AND DECALS .....	79
SCREWS & NUTS .....	80 - 81
WASHERS, BOLTS, & MISC. HARDWARE.....	82, 83, & 84
ELECTRONIC COMPONENTS .....	84

## GENERAL INFORMATION

### APPLICATION

This manual applies to Pepsi-Cola High Visibility Venders (HVV), beginning with HT2 production run 6730BZ and HT3 production run 6757DZ. HVV venders that were manufactured prior to production run 6730BZ have significant differences in programming and parts content from previous versions. The earlier versions were manufactured in production runs 6664DY, 6672DY, and 6698BZ. To order parts, or for information pertaining to these earlier versions, please contact Dixie-Narco.

### VENDER SAFETY PRECAUTIONS

Please read this manual in its entirety. This service information is intended to be used by a qualified service technician, who is familiar with proper and safe procedures to be followed when repairing, replacing, or adjusting any Dixie-Narco vender components. All repairs should be performed by a qualified service technician who is equipped with the proper tools and replacement components, using genuine Dixie-Narco factory parts.



*REPAIRS AND/OR SERVICING ATTEMPTED BY UNINFORMED PERSONS CAN RESULT IN HAZARDS DEVELOPING DUE TO IMPROPER ASSEMBLY OR ADJUSTMENTS WHILE PERFORMING SUCH REPAIRS. PERSONS NOT HAVING A PROPER BACKGROUND MAY SUBJECT THEMSELVES TO THE RISK OF INJURY OR ELECTRICAL SHOCK WHICH CAN BE SERIOUS OR EVEN FATAL.*

### PRODUCT IDENTIFICATION

First production of HT2 was June 2001.  
First production of HT3 was December 2001.

The production date of Dixie-Narco products is determined by the date code incorporated in the serial number.

The vender serial number takes the form xxxx-yyyzzz. The first 4 digits (xxxx) identify the specific vender. The next 4 digits (yyyy) identify the manufacturing run that the vender was built in. The last two alpha characters (zz) identify the quarter and the year the vender was built. The first alpha-character identifies the quarter.

A = 1st quarter  
B = 2nd quarter  
C = 3rd quarter  
D = 4th quarter

The second alpha-character identifies the year:

Y = 2000  
Z = 2001  
A = 2002  
B = 2003  
C = 2004  
D = 2005

### PHYSICAL CHARACTERISTICS

	501E
HEIGHT	72.5"
WIDTH	37.5"
DEPTH	36.0"
DEPTH WITH VALIDATOR	36.0"
SHIPPING WEIGHT	783 lbs.



## INSTALLATION & SETUP

---

The Dixie-Narco Pepsi-Cola High Visibility Vender is designed utilizing the latest technology.

### **UNPACKING THE VENDERS**

Remove the stretch wrap and top cover from the vender. Product cards are installed in the select buttons.



*DO NOT STORE THE VENDER OUTSIDE WITH THE STRETCH WRAP ON. THIS COULD CAUSE THE STRETCH WRAP TO BOND TO THE VENDER'S SURFACE, WHICH COULD DAMAGE THE FINISH.*

Remove the shipping boards from the bottom of the vender. The shipping boards are attached by the leveling legs. To avoid unnecessary damage to the leveling legs or base, remove the shipping boards by using a 1½ " "socket type" wrench to unscrew the leveling legs. Be sure to replace the legs after removing the shipping boards.

### **ELECTRIC POWER NEEDED**

Refer to the cabinet serial number plate to determine the proper voltage and frequency the machine requires (domestically this requirement is 115 Volts, 60 Hertz). The cabinet serial plate also indicates the Ampere rating of the vender. Single phase, alternating current is required. The vender must be plugged into a properly rated circuit with its own circuit protection (fuse/circuit breaker).

**DO NOT USE AN EXTENSION CORD.**

### **GROUND THE VENDER**

The vender is equipped with a three-wire power supply cord and **MUST** be plugged in a properly grounded outlet.

**DO NOT REMOVE THE GROUND PIN OR IN ANY WAY BYPASS THE GROUND OF THE VENDER.**

If the outlet will not accept the power cord plug, contact an electrician to install a proper AC outlet.



**FAILURE TO COMPLY WITH THESE INSTRUCTIONS MAY SUBJECT THE USER TO THE RISK OF INJURY OR ELECTRICAL SHOCK WHICH CAN BE SERIOUS OR FATAL.**

### **PEPSI ELECTRONIC DOOR LOCK**

The electronic lock provided in the vender consists of a door mounted, motor driven bayonet (shaft) system, a cabinet mounted nut receptacle switch system, an infrared controlled CPU, and a remote control key (FOB). The design is modular and allows for easy field service.

The electronic remote key (FOB) features a rolling code system which cannot be decoded if it is lost or stolen. After the vender has been unlocked, a new key can be programmed into it any number of times. If a key is lost or stolen, it is recommended you change the lock code in the field as soon as possible. Changing the lock code requires a new key and pressing the LEARN button inside the vender. The lock does not need to be changed for re-keying.

**Important:** For security reasons all Electronic Door Lock Venders are shipped less keys. Customers will need to contact the Electronic Door Lock manufacturer to order keys.

A power bypass connector, located in the product delivery port, allows auxiliary power to be applied via a battery pack to the electronic lock in the event that power is not available or there has been a failure of the internal power supply. In the event of an emergency, battery power is applied to the connector and the door can be opened and closed using the FOB.

The electronics uses an infrared transmission system, which functions similar to a television remote control. The transmission signal is line-of-sight, which requires you to aim the remote at a specific place at close range to prevent the accidental opening of several venders at the same time.

## INSTALLATION & SETUP

---

### TO OPEN THE PEPSI ELECTRONIC DOOR LOCK:

1. Plug the vender into a properly powered outlet.
2. Hold the key FOB 0 to 3 inches to the right side of select button #10 and press the button on the key FOB.  
Note: The wide end of the FOB should face the door.
3. The lock will begin releasing the door. The display will indicate **Door opening**. After the motor has stopped running, you can pull the door open. The display will indicate: **Door unlocked**.

### TO CLOSE THE PEPSI ELECTRONIC DOOR LOCK:

#### **CAUTION: DO NOT SLAM THE DOOR CLOSED.**

Slamming the door closed can damage the electronic locking device.

1. Push the door to the cabinet until the lock motor starts. The display will indicate: **Door closing**.
2. Continue to push the door for approximately 2 to 3 seconds after the lock motor starts. The lock will pull the door closed tightly.
3. When the lock motor stops the door will be locked and the display will indicate: **Door locked**.  
Before leaving the vender, ensure that the door is locked.

The electronic door lock assembly is supplied by Tri Teq Lock and Security. Dixie-Narco, Inc. does not carry parts for the Tri Teq Electronic Door Lock. For parts and assistance, please contact:

Tri Teq  
701 Gullo  
Elk Grove Village, IL 60007  
Tel: 847-640-7002  
Fax: 847-640-7008  
Email: gary@triteqlock.com

### PLACING THE VENDER ON LOCATION

#### **!! CAUTION !!**



*DO NOT TRANSPORT THE VENDER TO OR FROM THE LOCATION LOADED WITH PRODUCT. DAMAGE TO THE VENDER MAY RESULT.*

The vender must be located on a solid, flat, and level surface. The vender must be positioned close enough to an electrical outlet that an extension cord is not required. If the machine will be subject to user misuse or vandalism, it is recommended that the vender be secured to the floor or wall as described in Dixie-Narco Technical Bulletin 344. Call the Dixie-Narco Technical Service Department or your Dixie-Narco Representative for assistance.

#### **LEVEL THE VENDER**

When the vender is level, the door can be opened to any position and it will not move by itself. Open the door to several different positions before deciding the vender is level. A carpenter's level will help verify the machine is level.

Make sure that all leveling legs are in contact with the floor. If you cannot level the vender in its current location, select another location. DO NOT place any objects under the machine.

#### **DANGER**

---

*THE VENDER MUST BE PROPERLY LOCATED AND LEVELED. IF THE MACHINE WILL BE SUBJECT TO USER MISUSE OR VANDALISM IT IS RECOMMENDED THAT THE VENDER BE SECURED TO THE FLOOR OR WALL AS DESCRIBED IN DIXIE-NARCO TECHNICAL BULLETIN 344 TO MINIMIZE THE RISK OF INJURY OR DEATH FROM TIPPING.. CALL THE DIXIE-NARCO TECHNICAL SERVICE DEPARTMENT OR YOUR DIXIE-NARCO REPRESENTATIVE FOR ASSISTANCE.*

---



#### **SPACE THE VENDER**

Do not block the rear of the vender. Keep the vender 4 inches (10 mm) from the wall to ensure adequate airflow to the condenser and compressor. At the front of the vender, make sure that nothing obstructs the air intake at the bottom of the main door. At the rear of the vender, make sure nothing obstructs the air exhaust at the bottom of the cabinet.

## INSTALLATION & SETUP

### COIN CHANGERS & OTHER ACCESSORIES

The vender must have an MDB coin changer installed and can have an MDB bill acceptor installed. If the MDB coin changer and other MDB accessories are not factory installed, refer to the instructions received from the manufacturer of the MDB coin changer and other MDB accessories for proper set-up and installation.

The vender will support the following MDB coin changers:

Multi-Drop Coin Mech (Domestic)  
Coinco 9302GX  
Coinco USQ G700 Series  
Conlux USLZ-101  
Conlux CCM5G  
Mars 4510  
Mars 6512

The vender will support the following MDB bill validators:

Multi-Drop Bill Validators (Domestic)  
Coinco BA30B, BA50, MAG30, MAG50  
Mars VN2512, VN2502, VN2312  
Conlux NBM-3120, NBU-2111-12  
Ardac 5500 Series

The vender will support the following MDB card readers:

At publication, card reader dispositions were not available. Contact card reader manufacturer for proper installation and setup.

### LOADING CHANGE TUBES

Open the main door and enter the "FILL CM" mode in the "CASH SET" sub-menu in Programming (see Section B – Programming).

Load the coin mechanism with coins by inserting coins in the coin mech's separator. The display will show the total value of coins as they are inserted.

*Note: A low coin level in the coin tubes will interfere with operation of the bill validator.*

For additional information about coin mechanisms, refer to the specific manufacturer's instructions.

### Loading Product

The Pepsi-Cola High Visibility Vender is designed to vend a wide range of cans, glass, and plastic beverage containers in sizes from 12 oz. to 24 oz.

All Pepsi-Cola High Visibility Venders are shipped ready to vend 20 oz. Pepsi Quick Slam (Swirl) PET bottles. To vend an alternative package in the Pepsi-Cola High Visibility Vender, contact a Dixie-Narco Factory Service Representative or refer to the proper Technical Bulletin for shimming and set-up information.

### INITIAL LOADING

To ensure proper loading, the wide column oscillator must be in the extreme left or right position. When loading the wide column, the first row of bottles should be loaded on the bottom bar of the oscillator. The second row of bottles must be loaded on the top bar of the oscillator. Always load complete rows; do not load only to the back or only to the front of the column.

The narrow column rotors must be in the "cup" position to receive the first row of bottles. When loading narrow columns, lay the rows of bottles in the column until the column is full.

DO NOT fill the columns to the top of the cabinet. Because the bottle stack will move up and down in the column during the vend cycle, allow about 2 inches at the top of the column. Correct loading will prevent service calls and ensure proper vending.

After loading the vender for the first time, ensure the vender is loaded and working properly by test vending each selection with money until the first bottle is delivered.

NOTE: To ensure proper airflow through the evaporator, DO NOT place bottles (or other foreign) objects in the bottom of the tank.

### SERVICE NOTE

#### Battery Backup

The Universal Control Board is equipped with a battery backup which is used to retain information programmed in the system (pricing, time, date, etc.) in case of power interruptions or any time the main power is off. When the vender is shipped, the battery is connected and memory is being maintained.

Disconnect the battery if the vender will be stored for a long period of time. The following steps will guide you through this procedure.

- Remove power from the vender by unplugging the main power cord from the wall receptacle.
- Locate the HT2 Universal Control Board or HT3 Controller on the main door. Remove the battery from its holder (B1).

**PEPSI-COLA HVV  
PROGRAMMING METHOD  
June 2001**

The controller has two modes of operation:  
NORMAL and SERVICE.

**NORMAL MODE:**

In Normal Mode, on power up display will show software installed in vender, then change to Ice Cold Pepsi message, Sold Out, Credit Value, or decimal point. If decimal is flashing, this indicates an error or problem recognized in the vender. When money is inserted, the display indicates the total amount of the deposit. The select buttons are used to select the product. In normal mode you may access an external menu for reading historical sales total, product total, product total by selection, and sales by price totals.

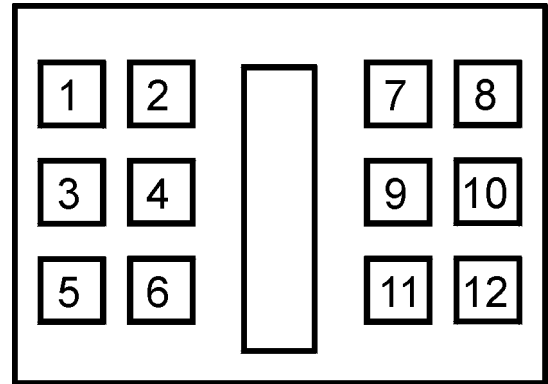

**SERVICE MODE:**

The Service Mode is entered when the vender door is open and the service switch is pressed. The display will show a list of error codes for errors that have occurred since the door was last opened. "Jammed Column #" is a vend mechanism jammed, "Select Switch #" is a select switch problem, "Refrigeration" is a refrigeration or temp sensor problem, and "Lock Error" is a door switch open problem. To acknowledge an error, press any select button, at this time you will enter the menu. The display will show "Historical Data" at this time. Some of the menu items have sub-menus.

To move through the menus and sub-menus follow these instructions. To:

- MOVE THROUGH MENU: Press select buttons 1 & 2 simultaneously to scroll down through the menu. While scrolling down through menu, release, press select buttons 1 & 2 simultaneously to scroll up through menu.
- ENTER SUB-MENU: Press and hold select button 1 to enter a sub-menu.
- EXIT SUB-MENU: With "Return" on display, press and hold select button 1 to exit a sub-menu.

**EXIT SERVICE MODE:**

Closing the inner door or a five-minute inactivity time-out will exit the service mode.

**FRONT PANEL PROGRAMMING  
SERVICE MENU**

**Historical Data**

This function shows the user the vender accounting over the life of the vender. Use the following select buttons to view the total sales in dollars, total number of vends and the total number of vends for each selection.

- Press Select Button 1: Shows the historical total cash sales for the life of the vender.
- Press Select Button 2: Shows the historical total number of vends.
- Press Select Button 3: Shows the historical number of vends by selection. Each selection automatically scrolls across the display.

Press & hold select buttons 1 & 2 simultaneously to move to the next item on the menu.

## INSTALLATION & SETUP

---

### Interval Data

This function shows the user the vender accounting data since the last time of the last counter reset. This data can be reset either from the menu or by DEX interrogation.

Press Select Button 1: Shows the total cash collected since the last counter reset

Press Select Button 2: Shows the total number of vends since the last counter reset.

Press Select Button 3: Shows the total number of vends by selection since the last counter reset Each selection automatically scrolls across the display.

Press Select Button 4: This button zeros the resettable data described above. Hold select button "4" for 5 seconds, "the display will go blank" and "Counters Reset" will be displayed. At this time, all resettable data will return to "0".

### Set Price

This function is used to set the price of each selection. When a select button is pressed, the price for that selection will be displayed. If the button is held in, the price will increment or decrement. To change from increment to decrement, release the select button and press it again. To set all selections for the same price: set the desired vend price on select #1, then simultaneously press and hold buttons 3 & 4 for 5 seconds the display will show "Single Price Set", this will change the vend price of all selections, both primary and secondary, to the price programmed to button #1.

Note: The HVV multi-pricing capability allows you to set all the selections to any price in the range of \$0.00 to \$99.95.

Press & hold select buttons 1&2 simultaneously to move to the next item on the menu.

### Cash Settings

#### Fill Coin Mech:

This function is used to count coins loaded in the top (separator) of the coin mech. Press select #1 will enter Fill Coin Mech. Press button #1 again will display a "0". Insert coins in the top (separator) of the coin mech. The total value of the coins will be displayed and will counted in the DEX audit data, so the controller knows exactly how much change is in the coin mech.

Press & hold buttons 1&2 simultaneously to move to the next item on the menu.

#### Dump Coin Mech:

This function is used to dump coins from the coin mechanism. Press select button #1 to enter mode and the lowest coin value dispensable will show on the display. Press and hold select buttons 1&2 simultaneously to scroll through the different coin values available to dump coins. Press and hold button #1 to dump the coins whose value is shown on the display. Press and hold select buttons 1&2 simultaneously until "Return" shows on the display. Press button #1 will return to "Dump Coin Mech".

#### Coin Rules:

This condition is used to allow the exact change condition to be turned on or off. When off, the controller will not go in the exact change condition. This will allow bills or coins to be accepted regardless of the tube level status of the coin mech. When turned on, the controller will set the exact change condition based on the ability to pay back non-refundable currency (ie. Coins, paper). To show current condition press select button 1. Press and hold select button 1 to toggle "Coin Rules" on and off.

## INSTALLATION & SETUP

---

### **Escrow:**

This function supports 4 (four) escrow options. To show the current condition, press select button 1 will enter mode and show current escrow setting. Press and hold select button 1 will scroll through the available Escrow options and set the escrow mode to setting displayed when the select button1 is released.

#### **Price 1**

This escrow condition is forced vend option 1 (“escrow to price”). All dollar bills will be stacked. No cancel sale is allowed once minimum vend price is met or exceeded.

#### **Price 2**

This escrow condition is forced vend option 2 (“escrow no cancel”) with all bills stacked, and no cancel sale allowed unless the vender is in exact change and the maximum vend price is exceeded. Note: Any money entered below the vend price cannot be returned.

#### **Select 4**

This escrow condition is “escrow to select” with all the dollar bills being stacked. Cancel sale will return the deposit from the coin changer (i.e.4 quarters).

#### **Select 1**

This escrow condition is “escrow to select dollar bills” with the last dollar bill that meets or exceeds maximum vend price being escrowed in the validator. Cancel sale will return the held dollar bill and any amount over \$1 will be returned from the coin changer.

Press & hold select buttons 1 & 2 simultaneously to move to the next item on the menu.

### **Multi Vend:**

This function, when turned on, allows credit to be retained after a vend so the customer can vend from another selection. (i.e..50 vend price, put in \$1.00, push a select button and vends, .50 still shows on the display, push a second select button and vends). Credit is cancelled after 5 minutes of inactivity. There is unlimited acceptance. If a customer wants their credit (money) back, the coin return lever must be pressed. To show the current “Multi Vend” condition, press select button 1 and the display will show the current setting. Press and hold button 1 to toggle Multi Vend from on and off.

Press and hold select buttons 1&2 simultaneously to move to “Return”.

### **Return:**

Press and hold button 1 to move to “Cash Settings”.

## INSTALLATION & SETUP

---

### User Menu:

This function is used to configure the vender to operate in a fashion best suited for the vender location. To move to "Diagnostics", press & hold select buttons 1&2 simultaneously, to enter the User Menu sub-menus press select button 1. The following are sub-menus of the User Menu: Space To Sales, Time, Language, Electronic Counter, Limited Access, Secondary Price, Light, Refrigeration, Free Vend, Override, Sales Message, Recharge, and Return.

### Space To Sales

To view the space to sales condition, press select button 1 and display will show "Selection 1". Alternating with columns assigned to that select button. Press select buttons 1&2 simultaneously to scroll through the available select buttons to view columns assigned and "Return".

#### To change space to sales:

Press select button 1 at the "Selection #" prompt and "Column ## #" (column edit routine) will be displayed, where the ## is the first column to added or deleted to the select button and the third # is "0" for not assigned or "1" for assigned to that selection. Press select button 1 with "Column ## #" on the display to toggle between "Column ## 0" and "Column ## 1". With the setting you wish to use showing on the display, press select buttons 1 & 2 to scroll to next selection to add/delete columns or "Return". Press select button 1 at the "Return" prompt will return to "Space to Sales".

Note: You must be in the "Selection" prompts to get to the "Return" mode that scrolls to "Space To Sales".

Press & hold select buttons 1 & 2 simultaneously to move to the next item on the menu.

### Time

This function is used to set the year, month, day, hour/minute (military 24 hour clock), and daylight savings time. Press select button 1 and "Year" will show on display. Press select buttons 1 and 2 simultaneously to scroll through all "Time" sub-menus.

- "Year"- Year Setting (00 to 99)  
Press select button 1 the current year setting will show on display.  
Press and hold select button 1 to increment the year setting (2000 to 2099).  
Release select button 1 and press and hold again will decrement the year setting.  
Release the select button with the display showing the year you wish to use and display will return to "Year".  
Press select buttons 1 & 2 simultaneously to scroll to "Month".
- "Month" - Month Setting (01 to 12)  
Press select button 1 and the current 2-digit month setting will show on display.  
Press and hold select button 1 to scroll through the month settings. (01-Jan. to 12-Dec.).  
Release the select button with the display showing the month you wish to use and display will return to "Month".  
Press select buttons 1 & 2 simultaneously to scroll to "Day".
- "Day" - Day of Month Setting (1 to 31)  
Press select button 1 and the current 2-digit day of month setting will show on display.  
Press and hold select button 1 to scroll through the day of month settings (1 to 31).  
Release select button 1 and press and hold again will decrement the day of month setting.  
Release the select button with the display showing the day of month setting you wish to use and display will return to "Day".  
Press select buttons 1 & 2 simultaneously to scroll to "Hour/Minute".

## INSTALLATION & SETUP

---

“Hour/Minute” - Hour and Minute Setting (0000 to 2359)

Press select button 1 and the current 4-digit hour and minute setting will be displayed (24 hour).

Press and hold select button 1: Set Hours

Press and hold select button 2: Set Minutes

Press select buttons 1&2 simultaneously to move to the next item in the menu.

### Daylight Savings Time

Press select button 1 and the current setting will show on the display.

Press and hold select button 1 to scroll through the “Daylight Savings Time” options listed:

“American” – North American rules – Set forward 1 hour at 2:00 am on the first Sunday in April; Set backward 1 hour at 2:00 am on the last Sunday in October.

“European” – European rules – Set forward 1 hour at 1:00 am on the last Sunday in March; Set backward 1 hour at 1:00 am on the last Sunday in October.

“Australian” – Australian rules – Set forward 1 hour at 1:00 am on the first Sunday in October; Set backward 1 hour at 1:00 am on the last Sunday in March.

“Off” – Off Rules – Daylight savings time change will not be made.

Release the select button with the display showing the “Daylight Savings Time” setting you wish to use and display will return to “Daylight Savings Time”.

Press and hold select buttons 1&2 simultaneously to move to “Return”.

Press select button 1 to move to “Time”

### Language

This function is used to set the language that will be used for display messages. To display the current language selected, press select button 1. To change the language selected, press & hold select button 1 to scroll through the language menu. Once the desired language is shown on the display, release the button. The display will then return to "Language".

English	Spanish
French	Slovene
German	Finnish
Italian	Norwegian
Portuguese	

Press and hold select buttons 1 & 2 simultaneously to move to the next item on the menu.

### Electronic Counter

This function is used to show historical cash sales, historical total vends, historical product counts by selection, and historical product counts that have occurred for prices being used from outside the vender. Press select button 1 to view the current four (4) button code. To view the data the four button code must be entered. Once entered the listed menus are available from the front of the vender:

Press select button 1: Show historical cash sales.

Press select button 2: Show historical total vends.

Press select button 3: Show historical product counts by selection.

Press select button 4: Show list of prices and historical product counts that have occurred for those prices.

Press select button 5: Returns to sales idle mode (normal vender operation).



## INSTALLATION & SETUP

---

To change "Electronic Counter" four button code:

At "Electronic Counter" press select button 1, "4231" (representing current four button code) will show on display. Press and hold select button 1 until the far left digit starts blinking indicating it can be changed. Press the select button which is desired for the code. The next digit will start blinking; press the select button which is desired for the code. Continue this process until all 4 digits are set. Note: The four-button code must use select buttons 1 through 9 only.

*Note: There is a five (5) minute time-out that will return the vender to normal vending mode.*

Press & hold select buttons 1 & 2 simultaneously to move to the next item on the menu.

### **Limited Access**

This function is used to program the vender to use the Limited Access Features. To move to Secondary Price Menu, press & hold select buttons 1 & 2 simultaneously, to enter the sub-menu press select button 1. The following are sub-menus of Limited Access Menu: "Selects", "Days", "Start 1", "Stop 1", "Start 2", "Stop 2", and "Return".

#### **Selects**

This function is used to set selection(s), which, will be limited during certain periods of the day. To view the selection setting condition, press select button 1. The display will show "Selection 01 - # where # is a "0" OR "1" depending on whether the selection is enabled (1) or disabled (0). Press and hold select button 1 to toggle between "0" & "1". Press select buttons 1 & 2 simultaneously to scroll through all available select buttons, "NONE", "ALL", and "Return". Pressing select button 1 when "ALL" or "NONE" are displayed will cause the display to flash momentarily. Press select button 1 at the "Return" prompt returns to "Selects".

Press & hold select buttons 1 & 2 simultaneously to move to the next item on the menu.

#### **Days**

This function is used to set the days of the week to be affected by limited access.

Day of Week:	Sunday	Wednesday	Saturday	Return
	Monday	Thursday	All Days	
	Tuesday	Friday	not found	

Press select button 1 and "Monday#" will show on the display, where # is "0" (disable) or "1" (enable). Press and hold select button 1 to toggle between "0" and "1". Release the select button with the display showing the setting you wish to use. Press select buttons 1 & 2 simultaneously to scroll through all available days, "All Days", "not found", and "Return". Press select button 1 at the "Return" prompt returns to "Days".

Press & hold select buttons 1 & 2 simultaneously to move to the next item on the menu.

#### **Start 1**

This function is used to set the hours and minutes to start period 1 limited access. Press select button 1 and the current four-digit hour and minute setting will to be displayed (24 hour).

Press & hold select button 1: Set Hours

Press & hold select button 2: Set Minutes

Press select buttons 1 & 2 simultaneously to move to the next item in the menu.

#### **Stop 1**

This function is used to set the hours and minutes to stop period 1 limited access. Press select button 1 and current four-digit hour and minute will be displayed. (24 hour).

Press & hold select button 1: Set Hours

Press & hold select button 2: Set Minutes

Press select buttons 1 & 2 simultaneously to move to the next item in the menu.

## INSTALLATION & SETUP

---

### **Start 2**

This function is used to set the hours and minutes to start period 2 limited access. Press select button 1 and the current four-digit hour and minute setting will be displayed (24 hour).

Press & hold select button 1: Set Hours

Press & hold select button 2: Set Minutes

Press select buttons 1 & 2 simultaneously to move to the next item in the menu.

### **Stop 2**

This function is used to set the hours and minutes to stop period 2 limited access. Press select button 1 and the current four-digit hour and minute setting will be displayed (24 hour).

Press & hold select button 1: Set Hours

Press & hold select button 2: Set Minutes

Press select buttons 1 & 2 simultaneously to move to the next item in the menu.

### **Return**

Press select button 1 to return to "Limited Access".

Press & hold select buttons 1 & 2 simultaneously to move to the next item on the menu.

## **Secondary Price**

This function is used to program a second price for each selection. To enter the sub-menu press select button 1. The following are sub-menus of Secondary Price Menu: "Price", "Days", "Start", "Stop", and "Return". Press select button 1 at "Return" to return to "Secondary Price".

### **Price**

This function is used to set the price of each selection. When a select button is pressed, the price for that selection will be displayed. If the button is held in, the price will increment or decrement. To change from increment to decrement, release the select button and press it again.

**Note:** The HVV multi-pricing capability allows you to set all selections to any price in the range of \$0.00 to 99.95.

Press & hold select buttons 1 & 2 simultaneously to move to the next item on the menu.

### **Days**

This function is used to set the days of the week to be affected by secondary pricing.

Day of Week:	Sunday	Wednesday	Saturday	Return
	Monday	Thursday	All Days	
	Tuesday	Friday	not found	

Press select button 1 and "Monday #" will show on the display, where # is "0" (disable) or "1" (enable). Press and hold select button 1 to toggle between "0" and "1". Release the select button with the display showing the setting you wish to use. Press select buttons 1 & 2 simultaneously to scroll through all available days, "All Days", "not found", and "Return". Press select button 1 at the "Return" prompt returns to "Days".

Press & hold select buttons 1 & 2 simultaneously to move to the next item on the menu.

### **Start**

This function is used to set the hours and minutes to start secondary pricing. Press select button 1 and the current four-digit hour and minute setting will be displayed. Press and hold select button 1 to change the hour setting, press button 2 to change the minute setting.

Press select buttons 1 & 2 simultaneously to move to the next item in the menu.

## INSTALLATION & SETUP

---

### Stop

This function is used to set the hours and minutes to stop secondary pricing. Press select button 1 and the current four-digit hour and minute setting will be displayed. Press and hold select button 1 to change the hour setting, press button 2 to change the minute setting.

Press select buttons 1 & 2 simultaneously to move to the next item in the menu.

### Return

Press button 1 to scroll to Secondary Pricing  
Press buttons 1 & 2 to scroll to the next item in the menu

## Light

This function is used to turn the lights off and on during certain periods of the day. Press select button 1 will enter "Days".

### Days

This function is used to set the days of the week to turn lights on and off.

Day of Week:	Sunday	Wednesday	Saturday	Return
	Monday	Thursday	All Days	
	Tuesday	Friday	not found	

Press select button 1 and "Monday #" will show on the display, where # is "0" (disable) or "1" (enable). Press and hold select button 1 to toggle between "0" and "1". Release the select button with the display showing the setting you wish to use. Press select buttons 1 & 2 simultaneously to scroll through all available days, "All Days", "not found", and "Return". Press select button 1 at the "Return" prompt returns to "Days".

Press & hold select buttons 1 & 2 simultaneously to move to the next item on the menu.

### Start

This function is used to set the hours and minutes to start lighting routine.  
Press select button 1 and the current four-digit hour and minute setting will be displayed. (24 hour).  
Press & hold select button 1: Set Hours  
Press & hold select button 2: Set Minutes

Press select buttons 1 & 2 to scroll to start.  
Press select buttons 1 & 2 simultaneously to move to the next item on the menu.

### Stop

This function is used to set the hours and minutes to stop lighting routine.  
Press select button 1 and the current four-digit hour and minute setting will be displayed. (24 hour)  
Press & hold select button 1: Set Hours  
Press & hold select button 2: Set Minutes

Press select buttons 1 & 2 to scroll to stop.  
Press select buttons 1 & 2 simultaneously to move to the next item on the menu.

### Enable

This function is used to allow the lighting routine to go in to affect.  
Press select button 1 and the current setting will be displayed (On or Off).  
Press and hold select button 1 to toggle between "On" and "Off".  
Release the select button showing the setting you wish to use and display will return to "Enable".  
Press select buttons 1 & 2 to scroll to "Return".

## INSTALLATION & SETUP

---

### Return

Press select button 1 to return to "Light".

Press & hold select buttons 1 & 2 simultaneously to move to the next item on the menu.

### Refrigeration

This function is used to electronically control the refrigeration operations of the vender.

Press select button 1 will enter "Temperature".

### Temperature

#### (Default Temperature 35°F/15°C)

This function is used to set the average product temperature for initial pull down and reload recovery.

Press select button 1 and "tt.tx" will show on the display where x is F (Fahrenheit) or C (Celsius) and tt.t is the degrees.

Press and hold select button 1 to increase or decrease the number by 1F or 0.5C. Release select button with the display showing the temperature you wish to use and display will return to "Temperature".

Press select buttons 1 & 2 to scroll to "Celsius or Fahrenheit".

### Celsius or Fahrenheit

This function is used to set the degree reading to Fahrenheit (F) or Celsius (C).

Press select button 1 and the current setting will show on the display. Press and hold select button 1 to toggle between F and C. Release the select button with the display showing the setting you wish to use and display will return to "Celsius or Fahrenheit".

Press select buttons 1 & 2 to scroll to "Display".

### Display

This function is used to enable the Temperature to be displayed following the "Ice Cold Pepsi" message.

Press select button 1 and "Display" will show on the display. Press select button 1 and the current setting will be displayed (On or Off). Press and hold select button 1 to toggle between "On" and "Off".

Press & hold select buttons 1 & 2 simultaneously to move to the next item on the menu.

### Days

This function is used to set the days of the week to use Temperature Setting Routine.

Day of Week:	Sunday	Wednesday	Saturday	Return
	Monday	Thursday	All Days	
	Tuesday	Friday	not found	

Press select button 1 and "Monday #" will show on the display, where # is "0" (disable) or "1" (enable). Press and hold select button 1 to toggle between "0" and "1". Release the select button with the display showing the setting you wish to use. Press select buttons 1 & 2 simultaneously to scroll through all available days, "All Days", "not found", and "Return". Press select button 1 at the "Return" prompt returns to "Days".

Press & hold select buttons 1 & 2 simultaneously to move to the next item on the menu.

### Start

This function is used to set the hours and minutes for storage temperature to become active.

Press select button 1 and the current four-digit hour and minute setting will be displayed (24 hour)

Press & hold select button 1: Set Hours

Press & hold select button 2: Set Minutes

Press select buttons 1 & 2 simultaneously to move to the next item on the menu.

## INSTALLATION & SETUP

---

### **Stop**

This function is used to set the hours and minutes for storage temperature to become inactive. Press select button 1 and the current four-digit hour and minute setting will be displayed (24hour).

Press & hold select button 1: Set Hours  
Press & hold select button 2: Set Minutes

Press select buttons 1 & 2 simultaneously to move to the next item on the menu.

### **Storage Temperature** **(Default Temperature 60°F/ 16°C)**

This function is used to set the temperature for product storage. Press select button 1 and "tt.tx" will show on the display where x is F (Fahrenheit) or C (Celsius) and tt.t is the degrees.

Press and hold select button 1 to increase or decrease the number by 1 F or 0.5 C. Release select button with the display showing the temperature you wish to use and display will return to "Storage Temperature"

Press select buttons 1 and 2 simultaneously to scroll to "Storage Enabled"

### **Storage Enabled**

This function is used to enable the storage setting to go in affect.

Press select button 1 and the current setting will be displayed (On or Off).

Press and hold select button to toggle between "On or Off".

Release the select button showing the setting you wish to use and display will return to "Storage Enabled"

Press select buttons 1 & 2 to scroll to "Return"

Press select button 1 at "Return" to scroll to "Refrigeration"

Press select buttons 1 & 2 simultaneously to scroll to next item on the menu.

### **Free Vend**

This function is used to set the Free Vend option. Note: For free vend to become active a free vend switch must be connected to controller on free vend switch connector. Press select button 1 and "Enable" will show on Display.

#### **Enable**

This function is used to allow the free vend to go in affect.

Press select button 1 and the current setting will be displayed (On or Off).

Press and hold select button 1 to toggle between " On or Off".

Release the select button showing the setting you wish to use and the display will return to "Enable".

Press select buttons 1 & 2 to scroll to "Display"

#### **Display**

This function is used to show the current number of free vends performed by the controller.

Press select button 1 and "#" will show on the display where "#" is the number of free vends performed by the controller. Release the select button and display will return to "Display"

Press select buttons 1 and 2 simultaneously to scroll to "Reset"

#### **Reset**

This function is used to reset number of free vends to zero.

Press and hold select button 1 for 5 seconds to reset the number of free vends performed by the controller to zero. Release the select button and the display will return to "Reset".

Press select buttons 1 & 2 to scroll to "Return".

#### **Return**

Press select button 1 to return to "Free Vend".

Press & hold select buttons 1 & 2 simultaneously to move to the next item on the menu.

## INSTALLATION & SETUP

---

### **Override**

This function is used to allow a key switch to override some of the settings stored for normal operations. When enabled and the override switch is in the closed position, the controller will override “Free Vend”, disable vending, disable currency acceptance, display will show “No Sales”, and lights will be off. Vender will remain in this idle state until the override switch is in the open position.

Press select button 1 and the display will show the current setting for 2 seconds (On or Off).

Press and hold select button 1 to toggle between “On” – enabled and “Off” – disabled.

Release the select button showing the setting you wish to use and display will return to “Override”.

Press select buttons 1 & 2 to scroll to “Sales Message”.

### **Sales Message**

This function is used to turn on the scrolling message “Ice Cold Pepsi”.

Press select button 1 and the display will show the current setting (On or Off).

Press and hold select button 1 to toggle between “On or Off”.

Release the select button showing the setting you wish to use and display will return to “Sales Message”.

Press select buttons 1 & 2 simultaneously to scroll to “Recharge”

### **Recharge**

This function is used to enable the recharge card setting routine.

Press select button 1 and the display will show the current setting (On- recharge card enabled or Off- recharge card disabled). Press and hold select button 1 to toggle between “On and Off”.

Release the select button showing the setting you wish to use and display will return to “Recharge”.

Press select buttons 1 & 2 simultaneously to scroll “Return”

### **Return**

Press select button 1 to return to “User Menu”.

Press & hold select buttons 1 & 2 simultaneously to move to the next item on the menu.

### **Diagnostics**

This function allows you to systematically diagnose problems related to the vender. To move to “Auto Test” press select buttons 1 & 2 simultaneously, to enter sub-menu press select button 1. The following are sub-menus of Diagnostics Menu: “Selection”, “Sold Out Empty Test”, “Sold Out Full Test”, “Motors”, “Coin mech”, “Note Acceptor”, “Display”, “Relay”, and “Return”.

#### **Selection**

Press any select button, and the display will indicate the number of the select button pressed.

Press & hold select buttons 1 & 2 simultaneously to the next item on the menu.

#### **Sold Out Empty Test**

Use this to test the sold-out switches if the vender is empty. Press select button 1 to display any sold out paddles that are not pressed, indicating that a column is empty. The display will automatically scroll through the columns that are sold out. Press select button 1 to return to “Sold Out Empty Test”.

Press & hold select buttons 1 & 2 simultaneously to move to the next item on the menu.

#### **Sold Out Full Test**

Use this to test the sold out switches if the vender is full. Press select button 1 to display any Sold Out Paddles that are pressed, indicating that the column is full. The display will scroll through the columns that have product. Press select button 1 to return to “Sold Out Full Test”.

Press & hold select buttons 1 & 2 simultaneously to move to the next item on the menu.

## INSTALLATION & SETUP

---

### **Motors**

Use this test to run any motor in the stack. Press select button 1 and “Motor 1” will show on the display. Use the following select buttons to run this test.

Press Select Buttons 1&2: Press until desired motor # to run or “Return” is shown on the display.

Press Select Button 1: Press to run the selected motor. The display will show “Vend” and the selected motor will run.

### **Coin mech**

Use this test to check coin mech, coin chute, and the coin mech payout systems. Insert coins. The value of the coins will be reflected on the display. Press select button 2 will exit the test and return any coins inserted and return to “Coin mech”.

Press select buttons 1 & 2 simultaneously to move to the next item on the menu.

### **Note Acceptor**

Use this test to check note acceptor. Insert a bill. Bill will be held in escrow. Press select button 2 to stack the bill. Press select button 3 to return the bill. After the note is has been stacked or returned, the display will return to “Note Acceptor”.

Press & hold select buttons simultaneously to move to the next item on the menu.

### **Display**

Press select button 1 and the display segments will illuminate in a scrolling manner and return to “Display”.

Press & hold select buttons 1 & 2 simultaneously to move to the next item on the menu.

### **Relay**

#### **Compressor #**

This function allows you to test the relay electronic control of the compressor.

CAUTION: Disconnect power to the compressor before testing the compressor relay. Failure to disconnect power to the compressor before testing the relay could result in damage to the compressor.

Press select button 1 and the display will show “Compressor #”, where # is the state of the relay 0 = not activated or off; 1 = activated or on. Press select button 1 to toggle the relay on and off.

Press select buttons 1 & 2 simultaneously to move to “Fan”.

#### **Fan #**

This function allows you to test the relay electronic control of the evaporator fan.

Press select button 1 and the display will show “Fan #” where # is state of the relay 0 = not activated or off; 1 = activated or on. Press select button 1 to toggle the relay on and off.

Press select buttons 1 & 2 simultaneously to scroll to “Light”.

#### **Light #**

This function allows you to test the relay electronic control of the lights.

Press select button 1 and the display will show “Light #”, where # is the state of the relay 0 = not activated or off; 1 = activated or on. Press select button 1 to toggle the relay on and off.

Press select buttons 1 & 2 simultaneously to scroll to “Return”.

Press select button 1 to return to “Relay”.

### **Return**

Press & hold select buttons 1 & 2 simultaneously to scroll to “Return”.

Press select button 1 to return to “Diagnostics”.

Press and hold select buttons 1 & 2 simultaneously to scroll to “Auto Test”.

## INSTALLATION & SETUP

---

### **Auto Test**

This function is used in Dixie- Narco's manufacturing process and is not intended for use in the field. It's purpose is a self-test routine to check the HVV components listed. For further details contact Dixie-Narco Factory Service. Press and hold select buttons 1 & 2 simultaneously to scroll to "Return".

### **Return**

Press & hold select buttons 1 & 2 simultaneously to scroll to "Return".  
Press select button 1 to return to normal operation.



# CONTROLLER PROGRAMMING

## PEPSI HVV QUICK REFERENCE MENU PROMPTS

Main Menu	Sub-Menu	Sub-Sub-Menu	Main Menu	Sub-Menu	Sub-Sub-Menu
Historical Data			User con't.	Light	Days
Interval Data					Start
Set Price					Stop
Cash Settings	Fill Coin Mech				Enable
	Dump Coin Mech				Return
	Coin Rules			Refrigeration	Temperature
	Escrow	Price 1			Celsius or Fahrenheit
		Price 2			Display
		Select 4			Days
		Select 1			Start
	Multi Vend				Stop
	Return				Storage Temperature
User Menu	Space To Sales				Storage Enable
	Time	Year			Return
		Month		Free Vend	Enable
		Day			Display
		Hour/Minute			Reset
		Daylight Savings Time			Return
		Return		Override	
	Language			Sales Message	
	Electronic Counter			Recharge	
	Limited Access	Selects	Diagnostics	Return	
		Days		Selection	
		Start 1		Sold Out Empty Test	
		Stop 1		Sold Out Full Test	
		Start 2		Motors	
		Stop 2		Coin mech	
		Return		Note Acceptor	
	Secondary Price	Price		Display	
		Days		Relay	Compressor #
		Start			Fan #
		Stop			Light #
		Return		Return	Return
			Auto test		
			Return		

A. Press and hold select buttons 1 & 2 simultaneously to move through the menu from top to bottom.

B. Press select button 1 to move left/right or enter/exit in the menu, depending on the menu prompt on the display.

# CONTROLLER PROGRAMMING

## Setting The Vender Type

When installing a service control board that has not been installed in a vender, the control board needs to set the vender type to recognize and perform proper space-to-sales options and vending operations.

To set the vender type:

1. Remove power to the vender.
2. Remove the existing control board.
3. Install the new control board.
4. Power-up the vender and the display will scroll "Set Model Number".
5. Press button 1 and the machine will display the model number available "501E".
6. Press buttons 1 and 2 simultaneously, this will allow the user to cycle through the available model numbers for that machine type. Once the desired model number is displayed "HVV", pressing button 1 will set this type.

**Note:** If the incorrect model number is set, the machine will not have the correct default space-to-sales arrangement. The user should power down the unit, unplug the battery, and reset RAM. The user should then begin the model number set routine again.

## Factory Default Setting

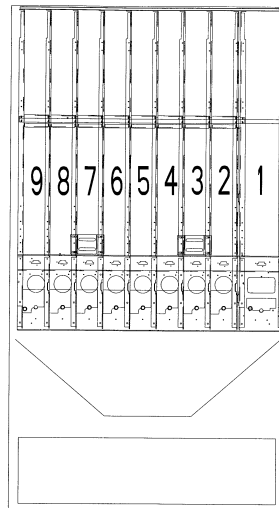
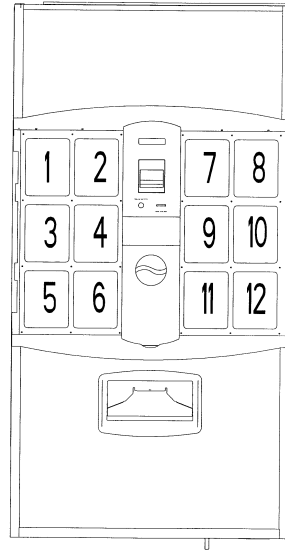

Selection #	Column #
1	1
2	1
3	2
4	3
5	4
6	4
7	5
8	6
9	7
10	8
11	9
12	9

## GENERAL MAINTENANCE

The most important facets of proper vender care and maintenance are the electrical power supplied to it, leveling, and cleanliness of the machine and its components.

### POWER

The vender must be connected to a dedicated 120VAC, 15 Amp circuit (U.S. and Canada).

#### CAUTION:

REMOVE POWER TO THE VENDER PRIOR TO CONNECTING / DISCONNECTING ANY ELECTRICAL COMPONENTS FOR TESTING OR REPLACEMENT.

### CLEANING



DO NOT USE A WATER JET OR NOZZLE TO CLEAN THE VENDER

### SIGN FACE

The polycarbonate sign face requires proper cleaning to prolong its service life. Periodically clean the sign as follows:

1. Rinse the sign with a soft cloth or sponge soaked in warm water.
2. If necessary, use a mild soap to loosen any dirt or grime. DO NOT SCRUB or use a brush or squeegee. Scrubbing may cause damage to signs with a clear ultraviolet resistant coating (prevents yellowing).
3. Repeat the above steps as necessary. To prevent spotting, dry the sign using a soft cloth.

### CABINET

1. Wash the cabinet with a good detergent or soap mixed with warm water.
2. Wax the vender often with a good grade of automobile wax.
3. Any corrosion inside of the vender should be removed with a fine steel wool and the area should be painted with aluminum paint.
4. Repair any scratches on painted surfaces to prevent corrosion.



THE COMPRESSOR ELECTRICAL CIRCUIT IS ALWAYS LIVE WHEN THE PLUG IS CONNECTED TO AN ELECTRICAL OUTLET

### REFRIGERATION CONDENSER

- Check the condenser periodically for dirt or lint build-up.
- Remove build-up with a brush or vacuum, or blow the dirt out of the condenser with compressed air and an approved safety nozzle.
- Ensure nothing obstructs the air intake at the bottom of the main door.
- Ensure nothing obstructs the air exhaust at the rear of the cabinet.

### COIN ACCEPTOR

- Follow the coin acceptor manufacturer's cleaning instructions.

### LUBRICATING THE VENDER

Time	Component	Lubricant Example
Every 6 months (or as needed)	<b>Main Door</b>	
	1. Lock Bolt & Nut Retainer 2. Hinge Pivot Points	Mechanics Friend Mechanics Friend
Every Year (or as needed)	<b>Inner Door</b>	
	1. Hinge Pivot Points <b>Inner Door</b> 1. Door Gasket	Mechanics Friend Petroleum Jelly

## INSTALLATION & SETUP

---

### ***EPROM REPLACEMENT***

Software changes / upgrades are accomplished by changing the EPROM on the Control Board.

To change EPROM:

Remove power to the vender.

Remove existing EPROM.

Replace the EPROM. (The EPROM's legs bend easily. Remove and replace very carefully.)

Note the alignment notch at one end of the EPROM and on the control board. The notches must be matched or problems will occur.

Apply power to the AC distribution box.

Display will scroll “\*/SOFTWARE/REV###.###/ICE COLD PEPSI/##.##”.

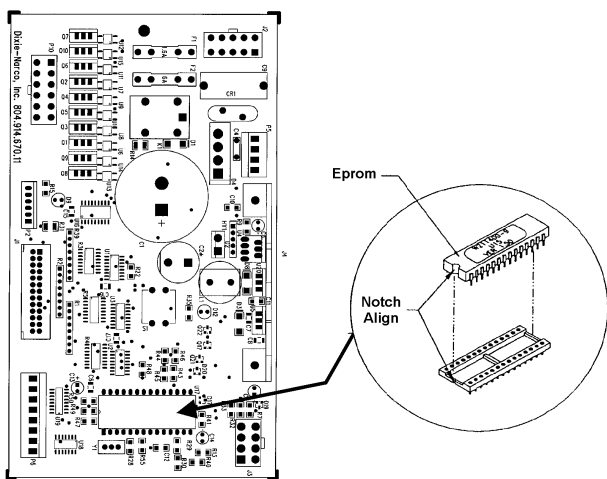

**Figure 1 – EPROM REPLACEMENT  
(SAMPLE BOARD SHOWN)**

## MAJOR COMPONENT DESCRIPTION

---

### ***ELECTRICAL***

Transformer	Provides 24 volt and 12 volt power to the Machine Controller
Fuse (F1)	1.6 Amp Slo Blo Control Board Power (includes display and MDB Peripherals)
Fuse (F2)	6.0 Amp Fast Blo Vend Motor Power
Relay	Potter & Brumfield T91P5D52-24 240VAC/20A-NO/10A-NC (Compressor, Light, Fan)
Power Line Filter	Schaffner (HT2) FN2020-6-06 110/250VAC / 50-60 Hz 6A@40 <sup>0</sup> C / -25 <sup>0</sup> C +85 <sup>0</sup> C
Choke	Foster (HT3) A-16015 5mH 6A

### ***REFRIGERATION***

110 VAC	
Compressor	Embraco, 1/3 HP, 115 VAC, 60 Hz 1 Phase Unit uses 7.5 oz. of 134A Refrigerant
Start Relay	110 VAC, 1.351.605
Start Capacitor	110 VAC 233-280 MFO / 165V
Thermal Overload	110 VAC MRT 22AF2-5598
Condenser Fan	6W Motor 110 VAC FV870CW25S Blade – 8- <sup>11</sup> / <sub>16</sub> " dia.
Evaporator Fan	6W Motor 110 VAC AD775CW32S Blade – 8- <sup>3</sup> / <sub>4</sub> " dia.

# MAJOR COMPONENT DESCRIPTION

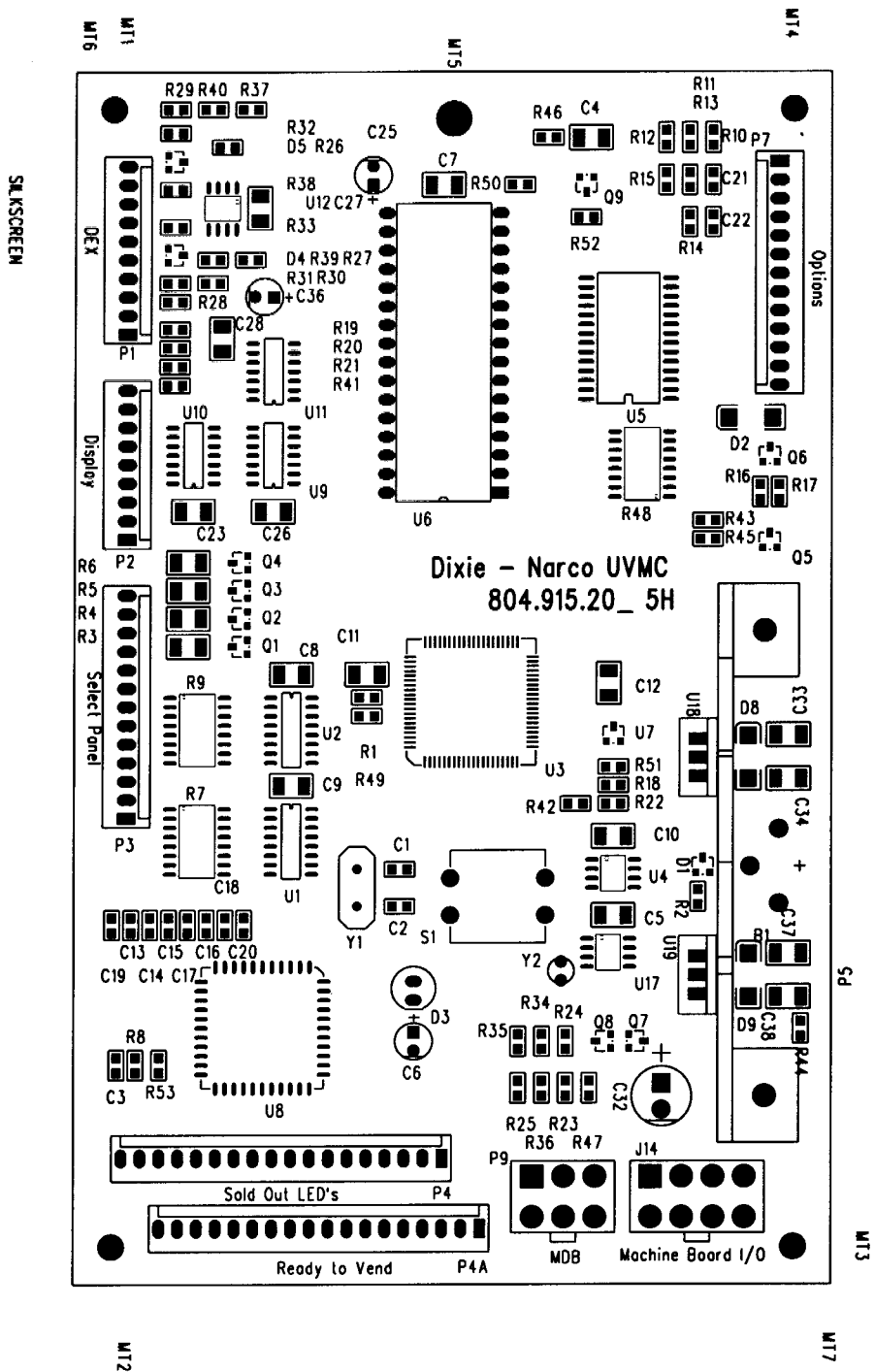

**HT2 UNIVERSAL CONTROLLER**

# MAJOR COMPONENT DESCRIPTION

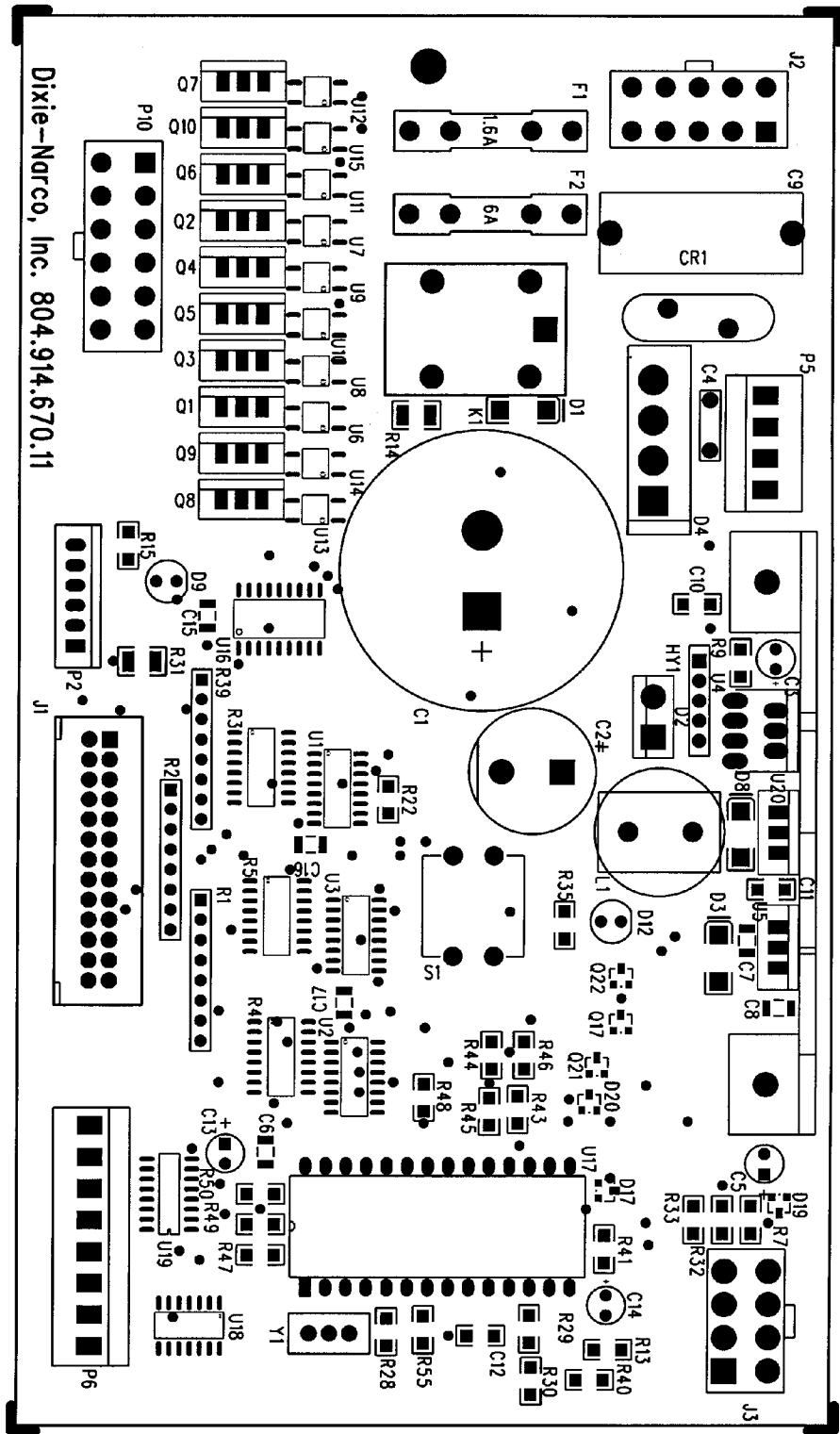

Dixie-Narco, Inc. 804.914.670.11

**HT2 MACHINE CONTROLLER**

- J2 Board Power to Transformer
- P10 Motor Extension Harness (connection)
- J3 Board to Board Interface (Machine Controller to Universal Controller)
- J1 Cabinet Extension Harness
- P2 & P6 Temp Sensor and Relay Extension

# MAJOR COMPONENT DESCRIPTION

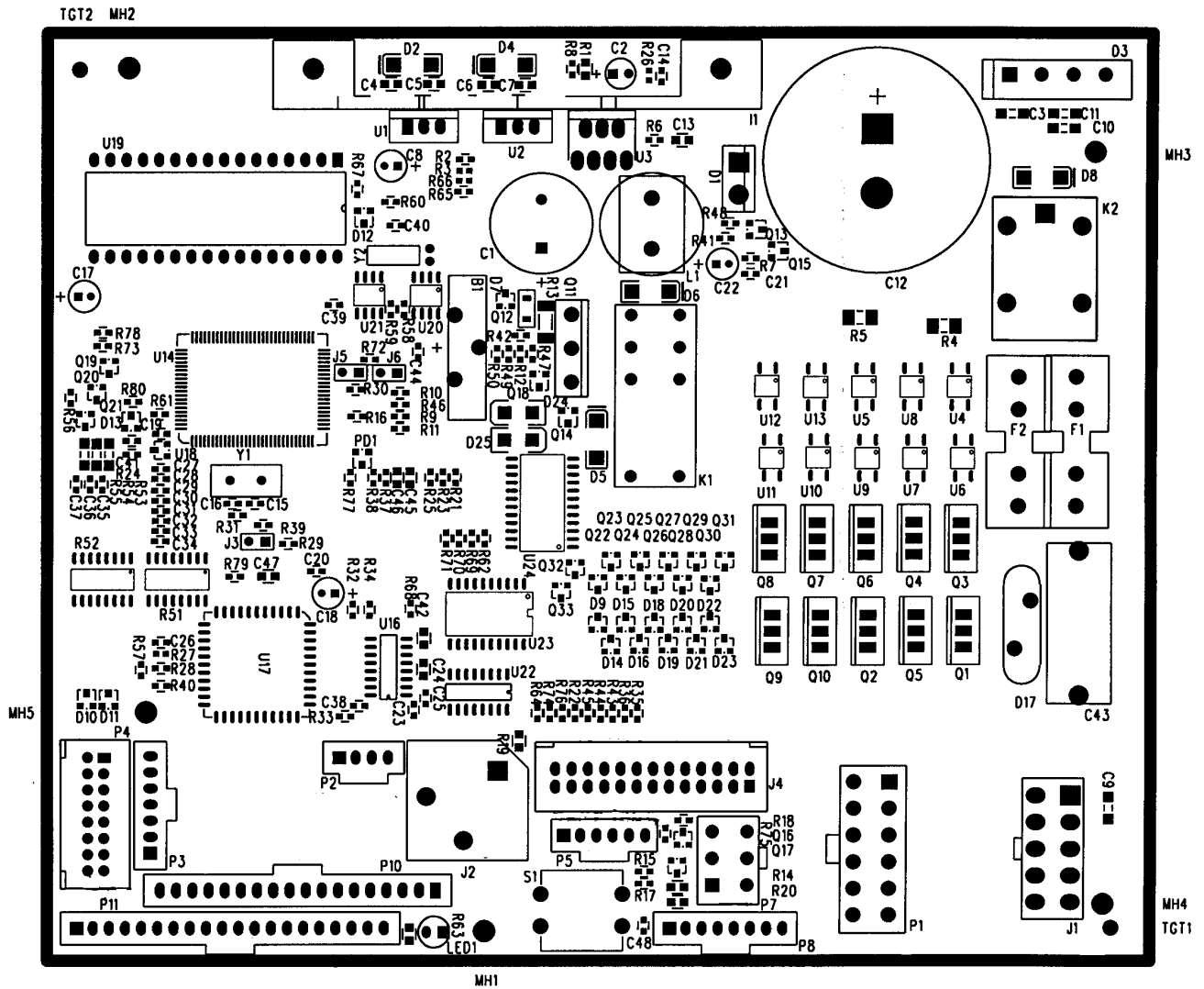

HT3 CONTROL BOARD

- P1 Motor
- P2 Secondary DEX
- P3 Display
- P4 Select Switches
- P5 Temp Sensor
- P7 MDB
- P8 Energy Management
- P10 Sold Out LED's
- P11 Ready to Vend
- J1 AC Power
- J2 DEX
- J4 Cam / Sold Out



# TROUBLESHOOTING FLOWCHARTS

These charts are intended to isolate and correct most problems you might encounter.

## ALL COINS ARE REJECTED

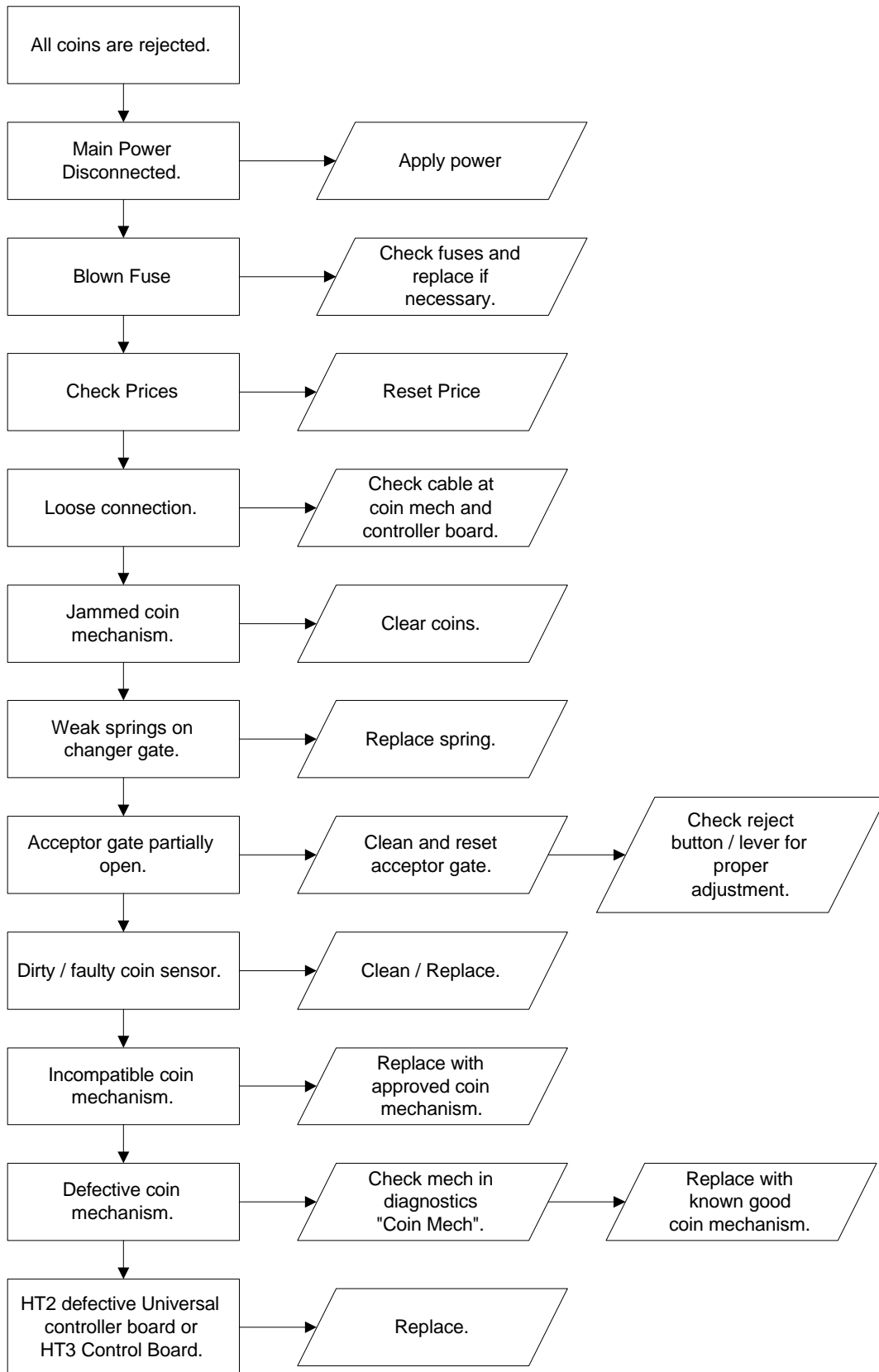

# TROUBLESHOOTING

## ALL BILLS ARE REJECTED

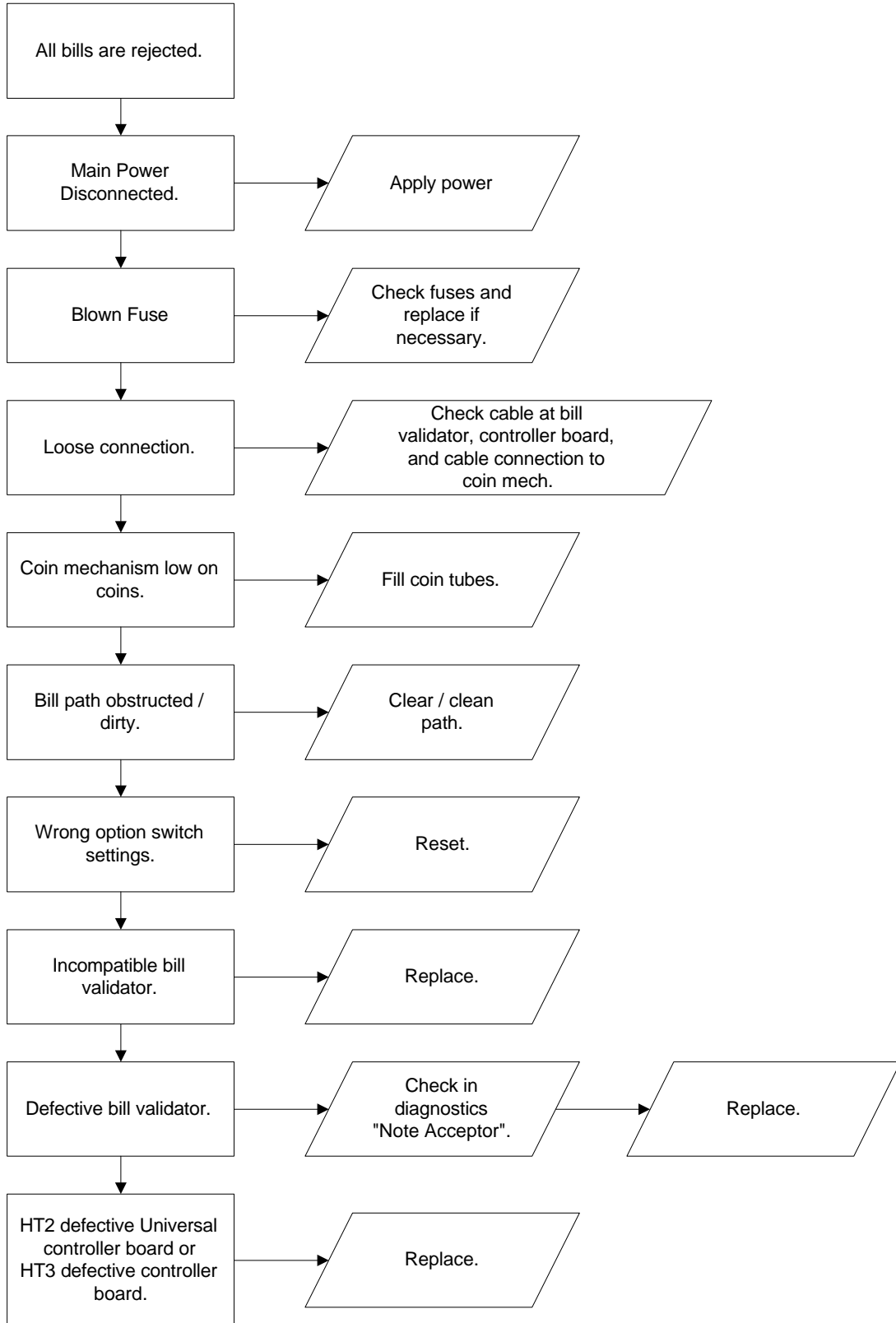

# TROUBLESHOOTING

---

## INCORRECT CHANGE DISPENSED

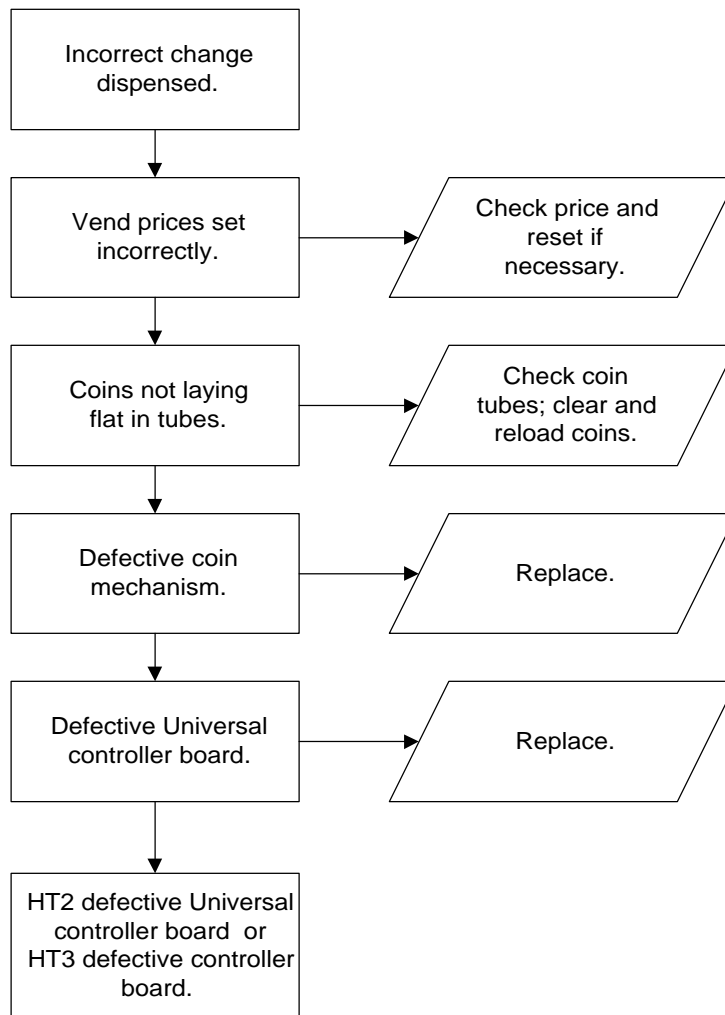

# TROUBLESHOOTING

## SELECTION WILL NOT VEND

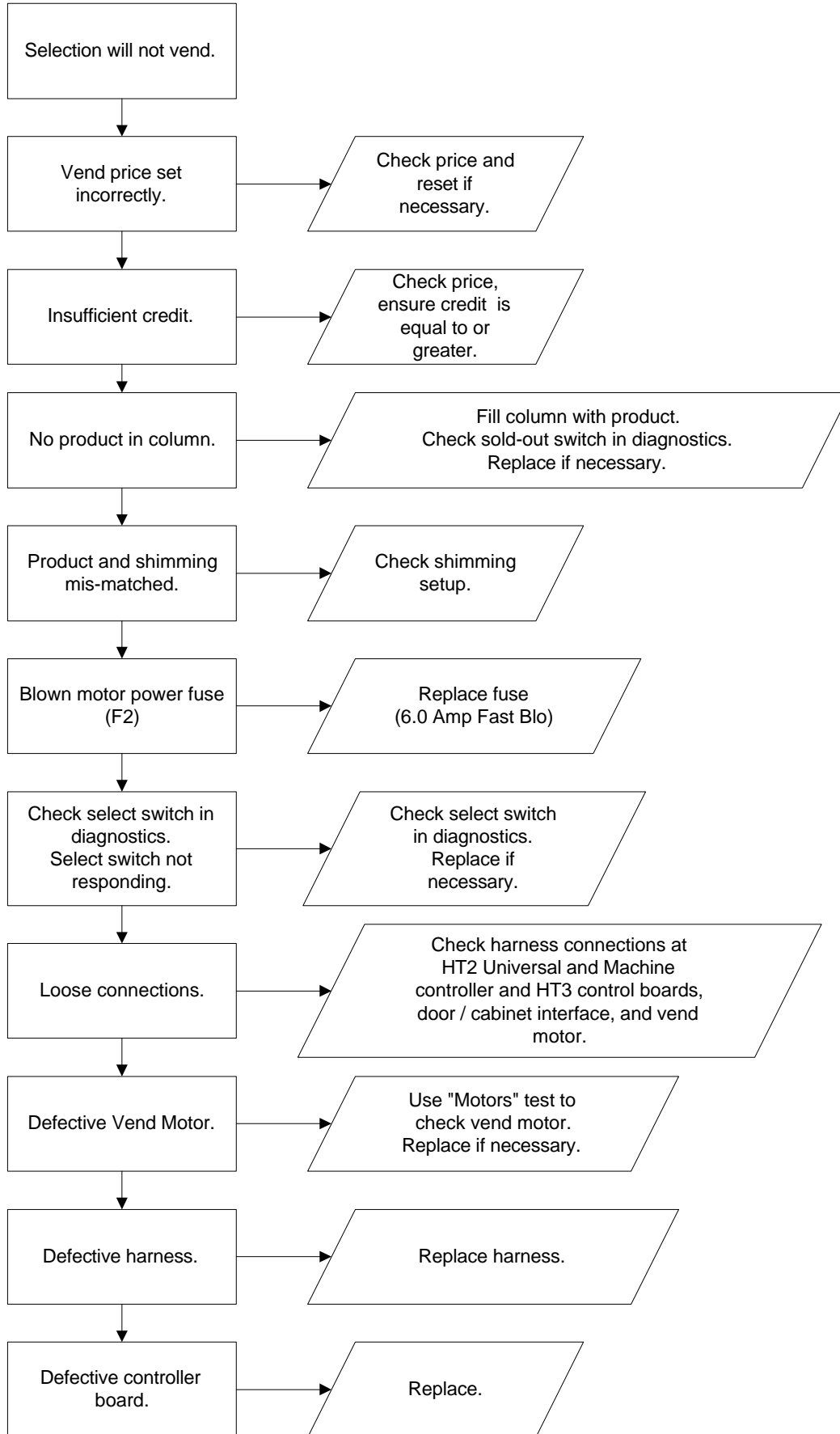

# TROUBLESHOOTING

## ICE / FROST ON EVAPORATOR

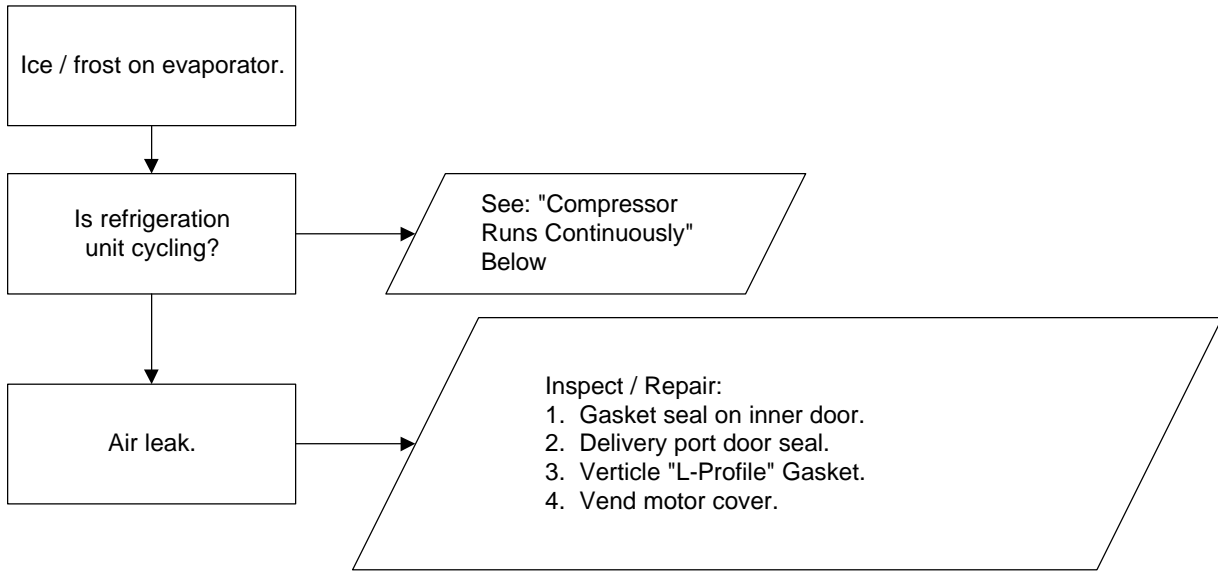

## COMPRESSOR RUNS CONTINUOUSLY

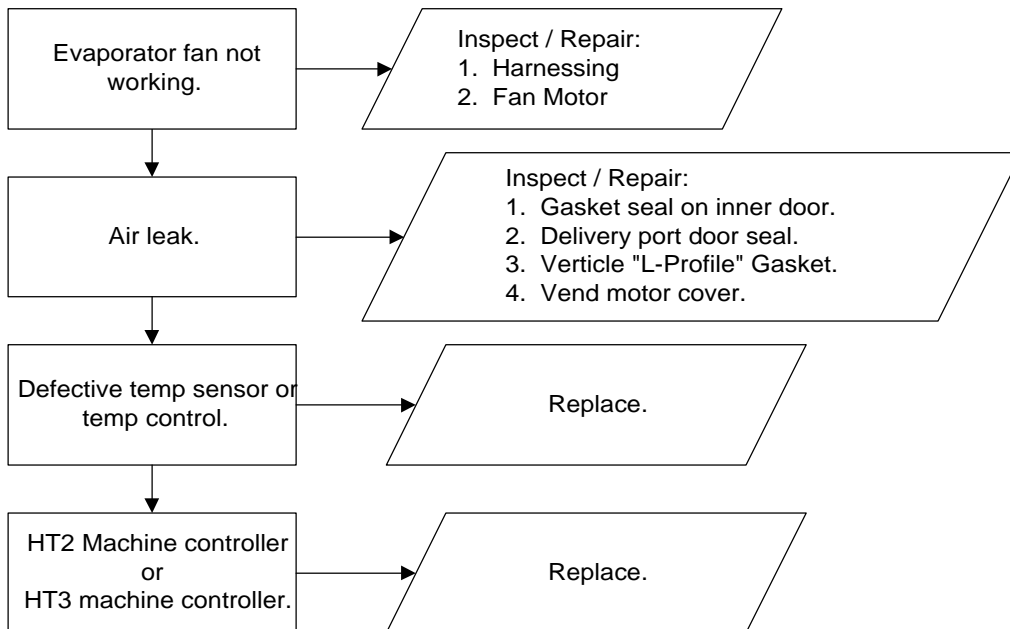

# TROUBLESHOOTING

## COMPRESSOR WILL NOT START

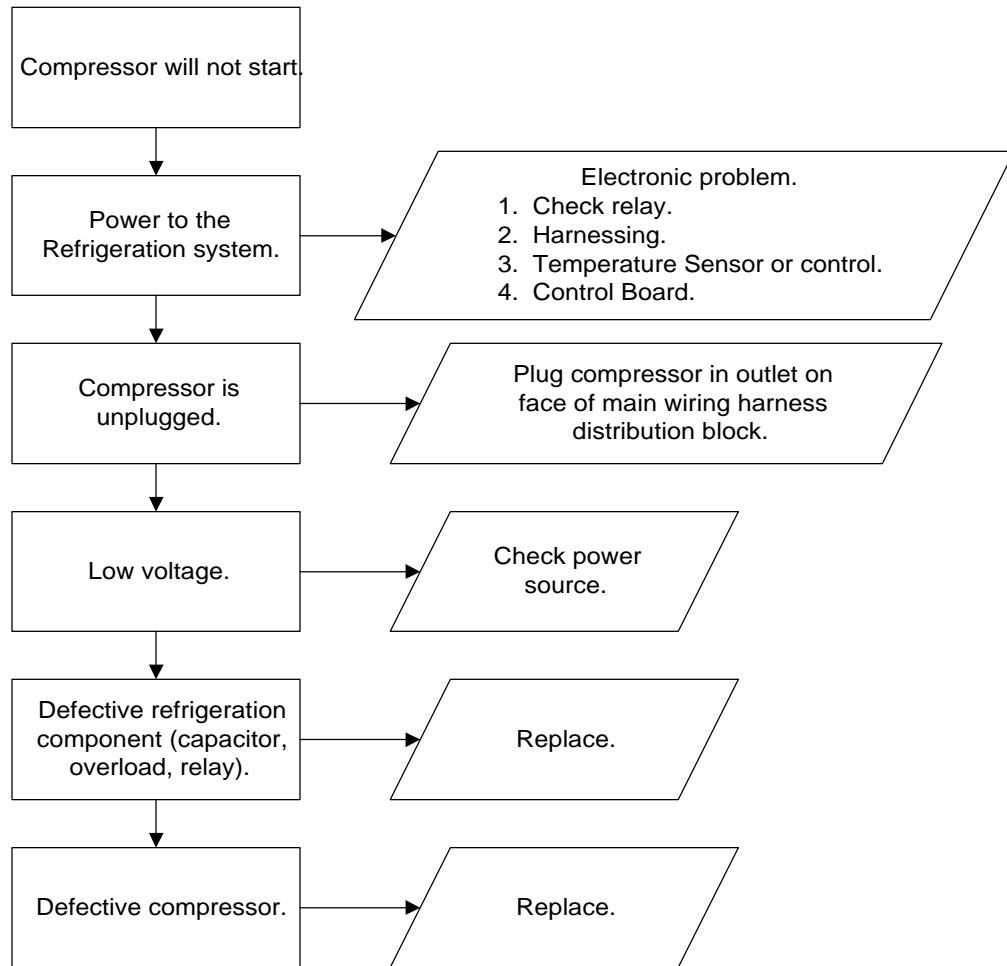

**Troubleshooting Tip:** Use a short 15 Amp extension cord and plug the compressor directly into the wall outlet. This will bypass the Electronic Controls.  
**Note:** For Testing Purposes Only.

# TROUBLESHOOTING

## MACHINE NOT COOLING

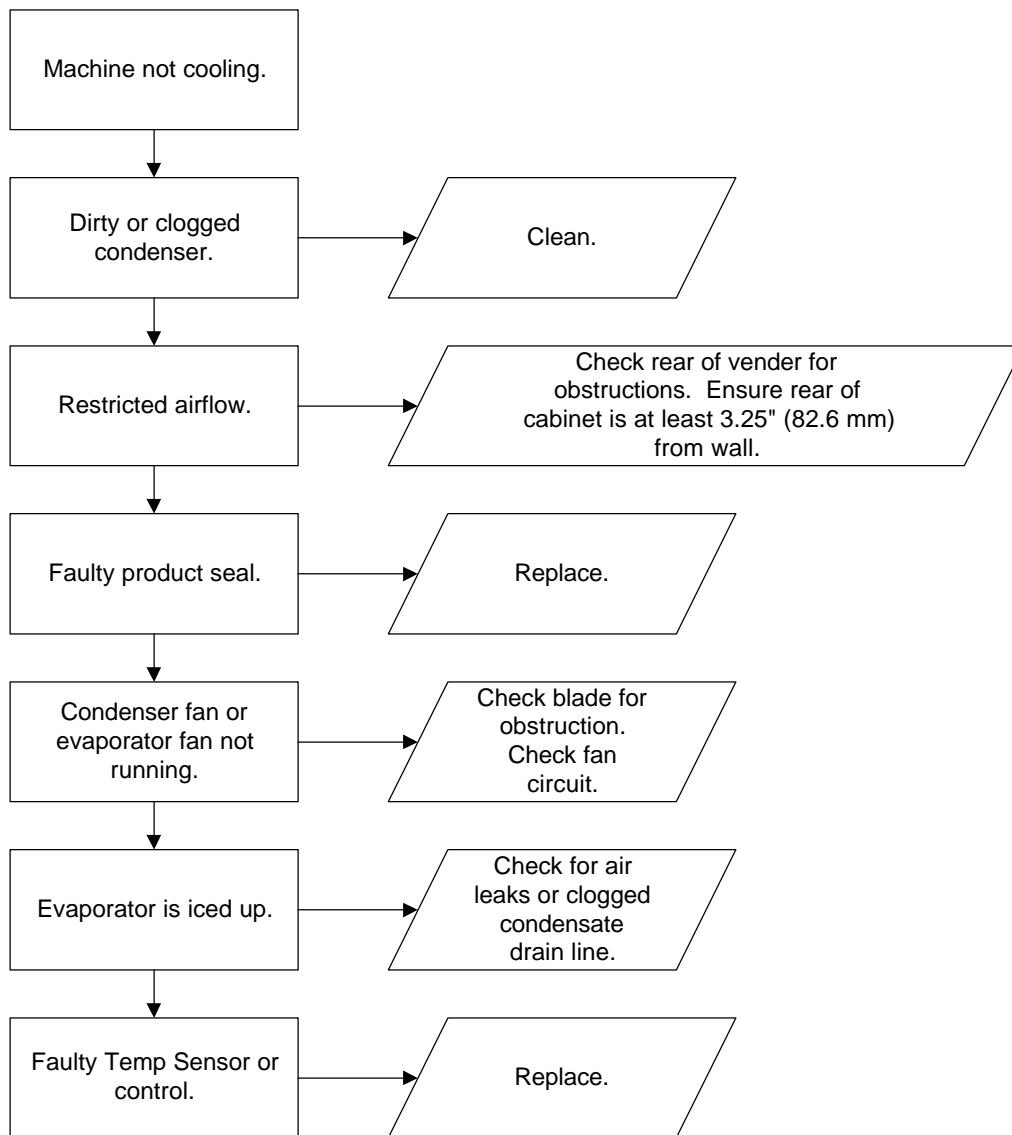

# TROUBLESHOOTING

## CAN'T ENTER THE MENU OR DIAGNOSTICS



**Note:** Prior to checking wires or connections, ensure power has been removed from vender.

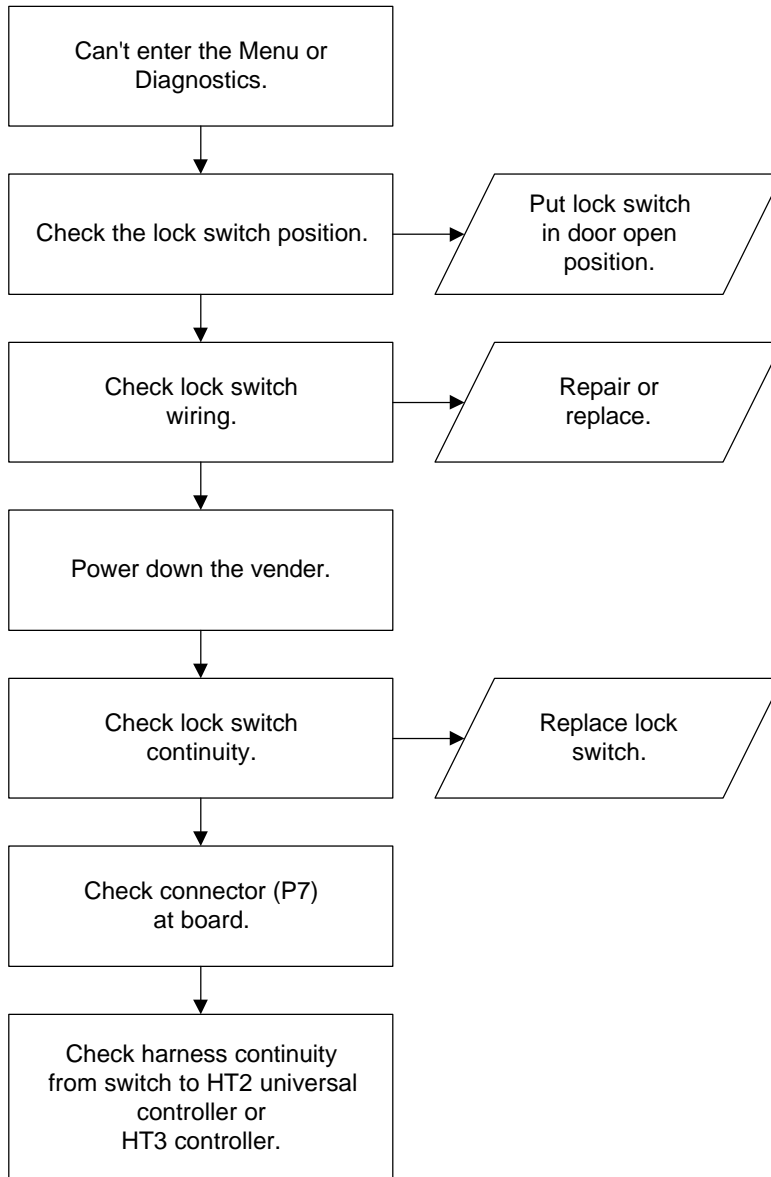



# TROUBLESHOOTING

---

## LIGHTS ARE NOT ON

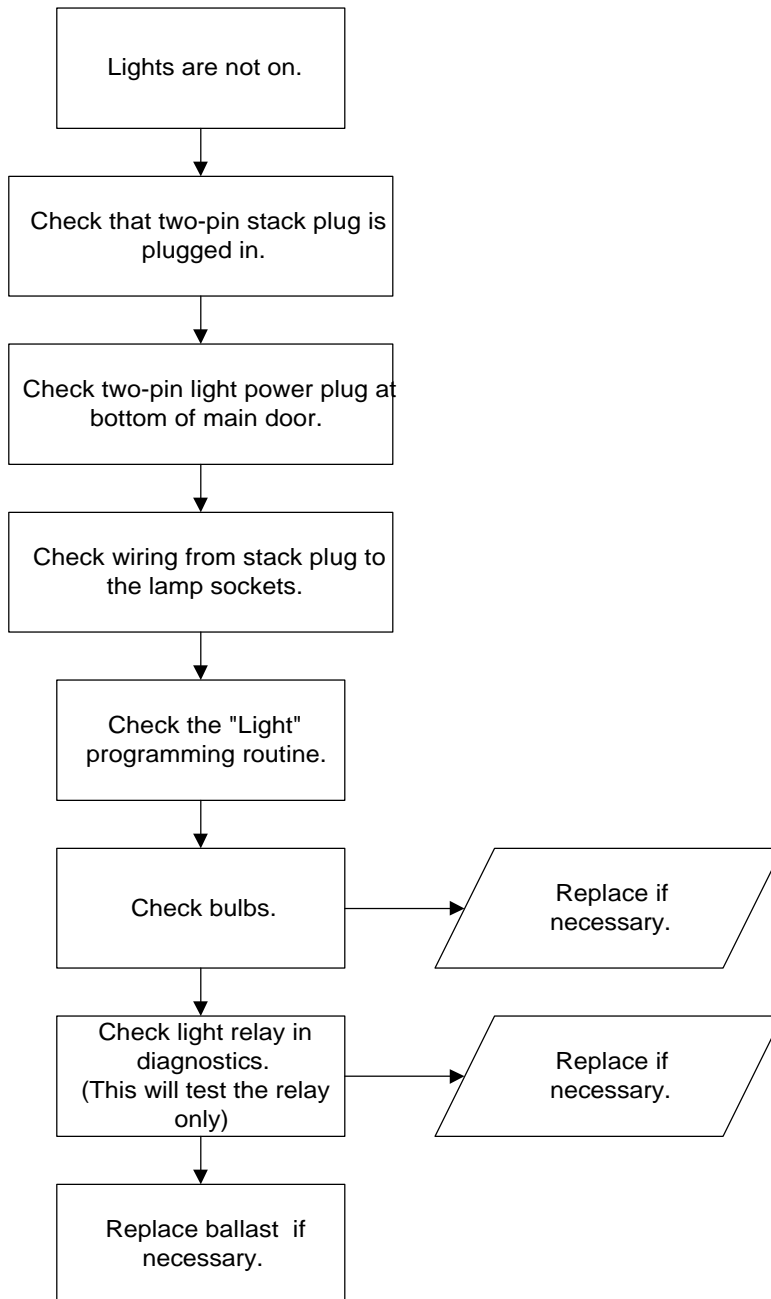

# TROUBLESHOOTING

## ONE OR MORE MOTORS RUN WHEN MAIN DOOR IS CLOSED (Display Scrolls "Homing")

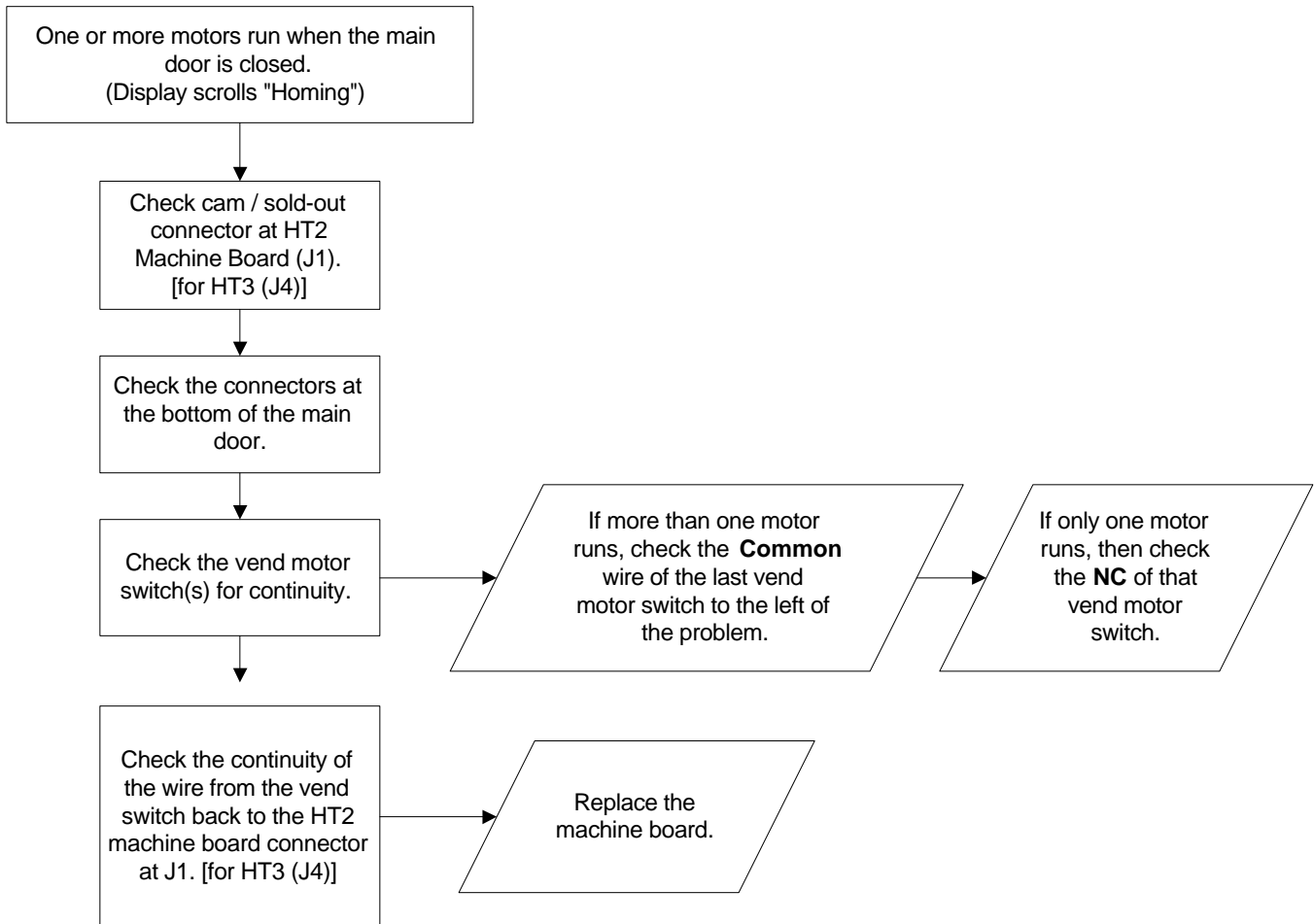

## SOLD OUT SWITCH

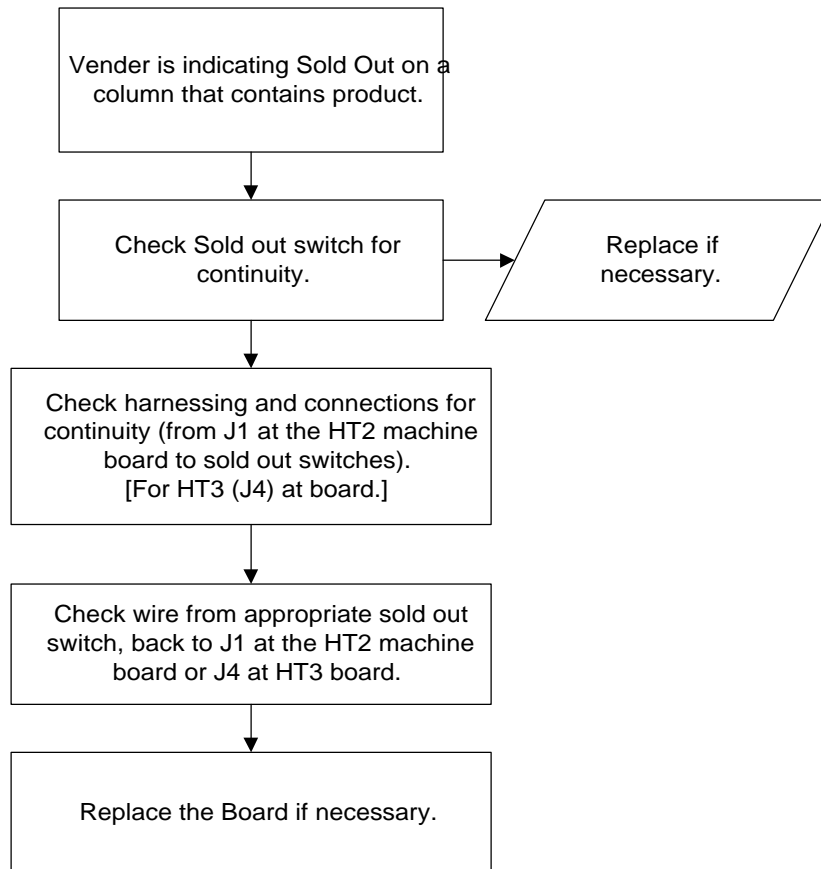

### THE DISPLAY IS DEAD

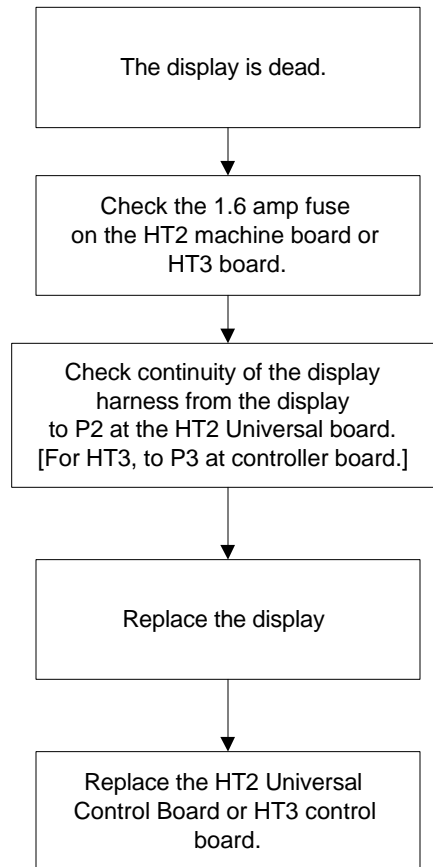

### CAN'T READ THE DISPLAY

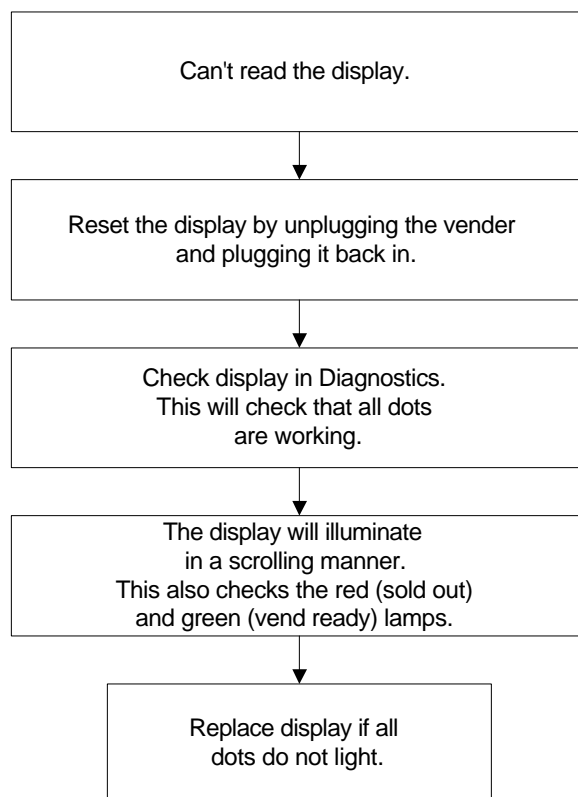

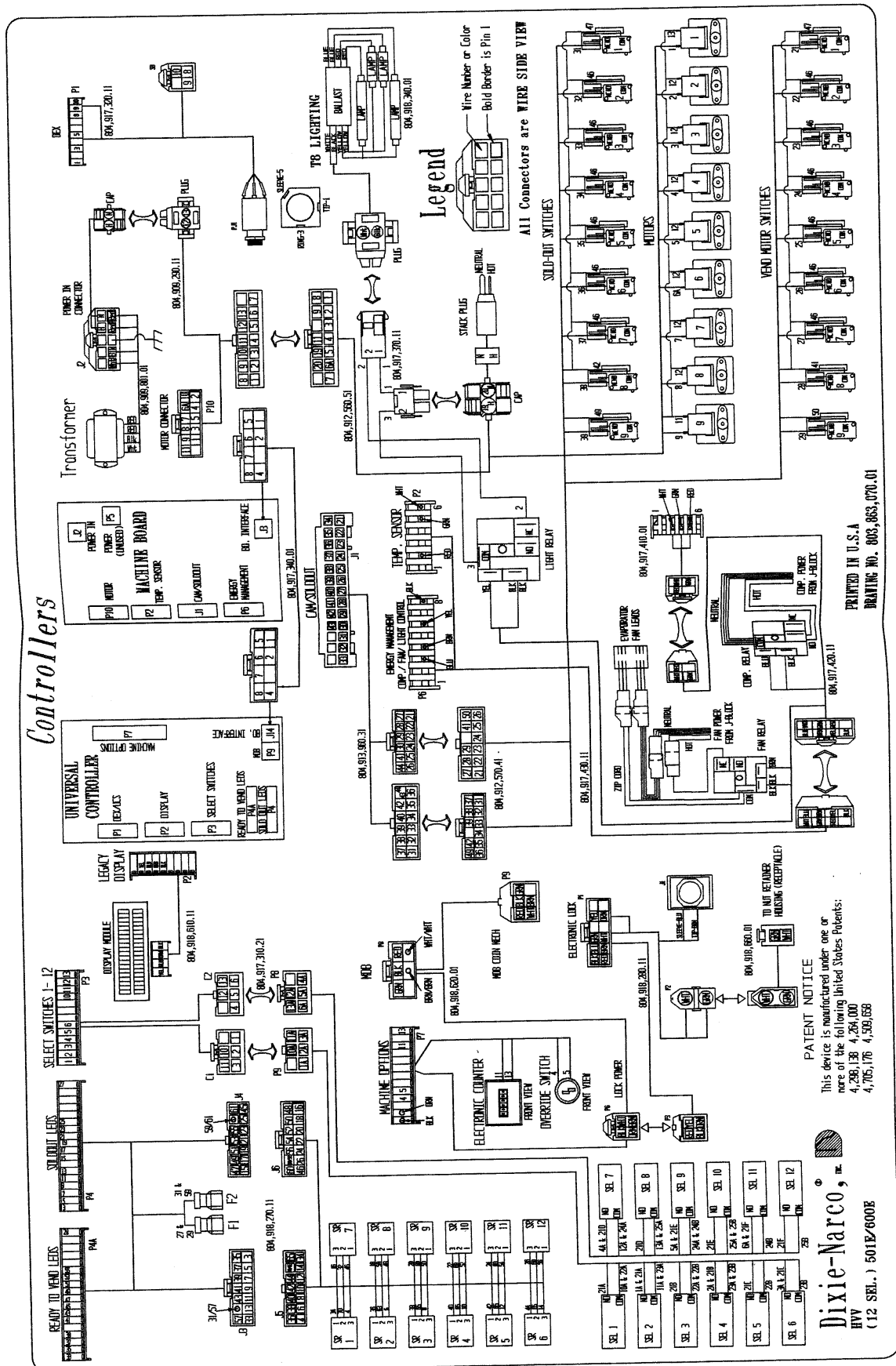

PRINTED IN U.S.A.  
DRAWING NO. 803,863,070.01

PATENT NOTICE  
This device is manufactured under one or more of the following United States Patents:  
4,286,138 4,284,000  
4,705,176 4,336,658

**Dixie-Narco, Inc.**  
HWV  
(12 SEL.) 501E/600E

HT2

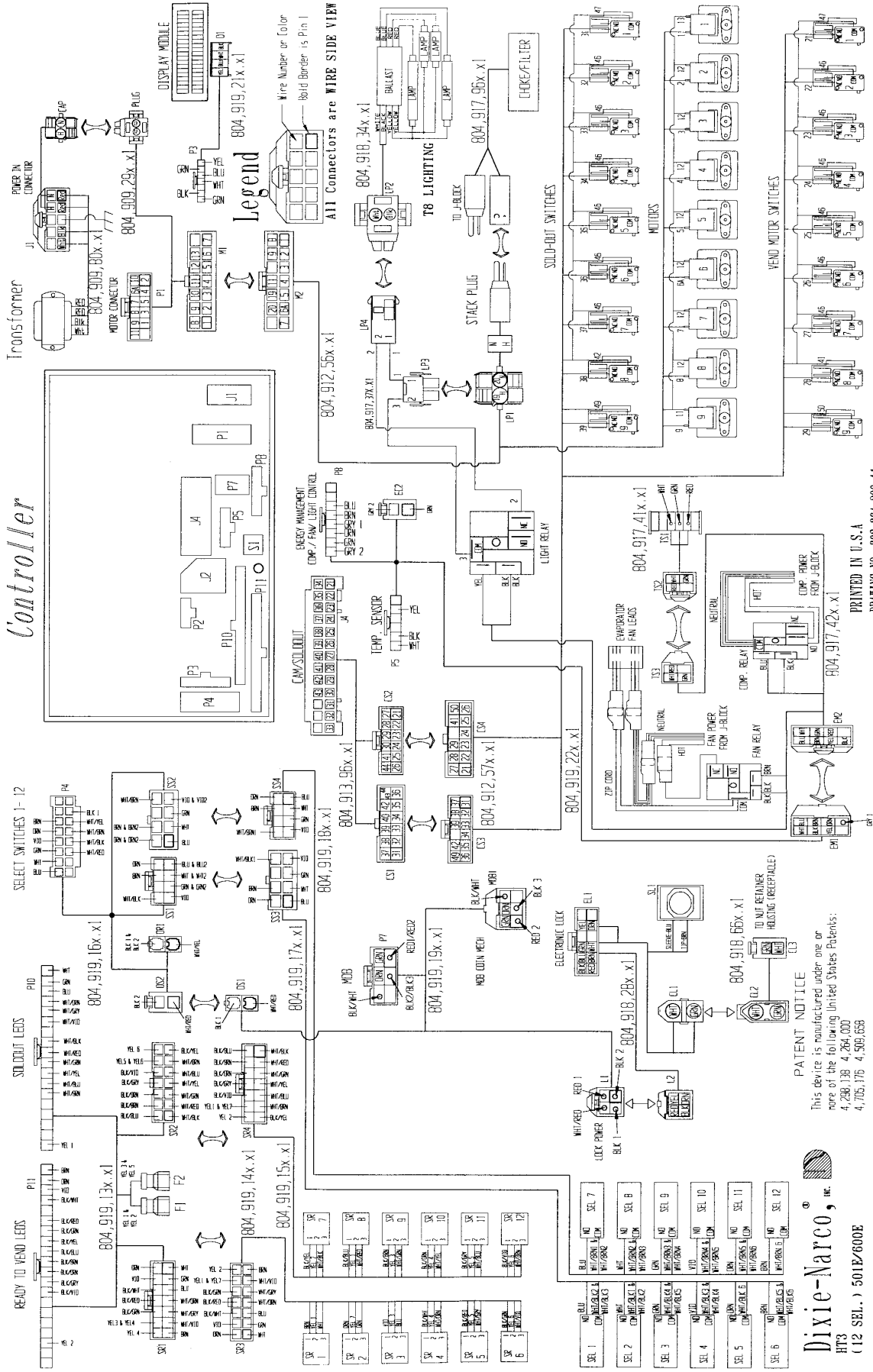

Controller

PRINTED IN U.S.A.  
DRAWING NO. 803,864,290.11

**PATENT NOTICE**  
This device is manufactured under one or more of the following United States Patents:  
4,288,138; 4,264,000;  
4,755,175; 4,506,558

**Dixie-Narco, INC.**  
HTS  
(12 SEL.) 501P/60DE

HT3

Refrigeration Circuit Diagrams

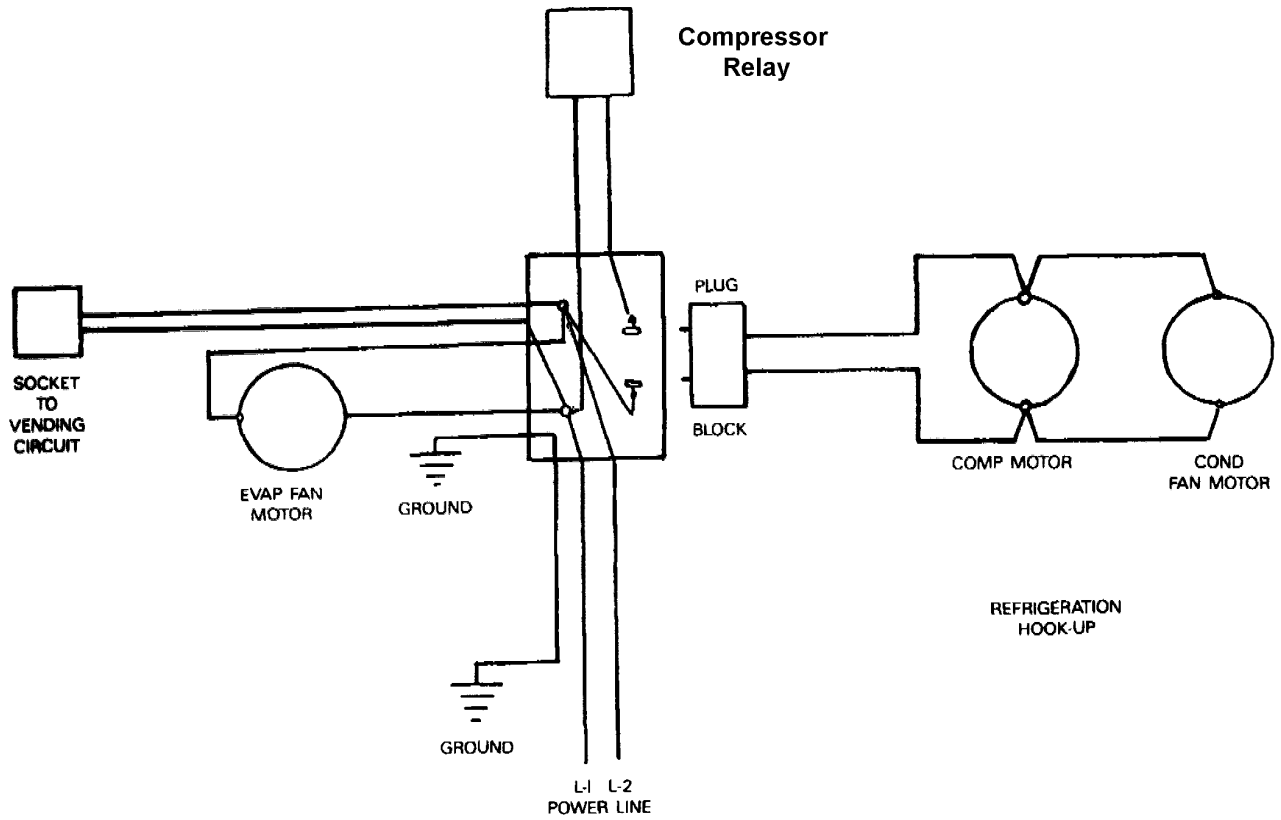

Embraco

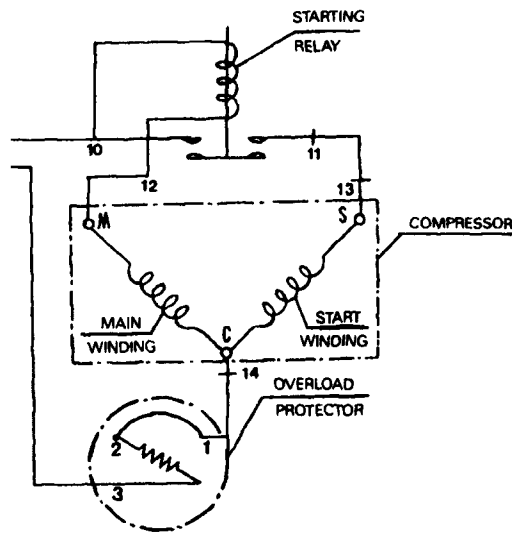



# WIRING DIAGRAMS AND SCHEMATICS

ITEM	DESCRIPTION	QTY
1	PLATE, MOUNTING RELAY	1
2	CHOKE, 5mH 6A FOSTER A-16015	1
3	HRNS, FILTER/STICK PLG (DETAIL "A")	1
4	SCREW, 8-32 x 3/8 PHIL PAN SEMS	2
5	CLAMP, NYLON 3/8 ID	1
6	SCREW, 8-18 x 1/2 PHIL PAN	2
7	SCREW, TAP 10-32 x 1 1/2	1

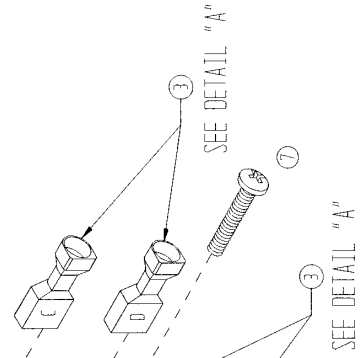
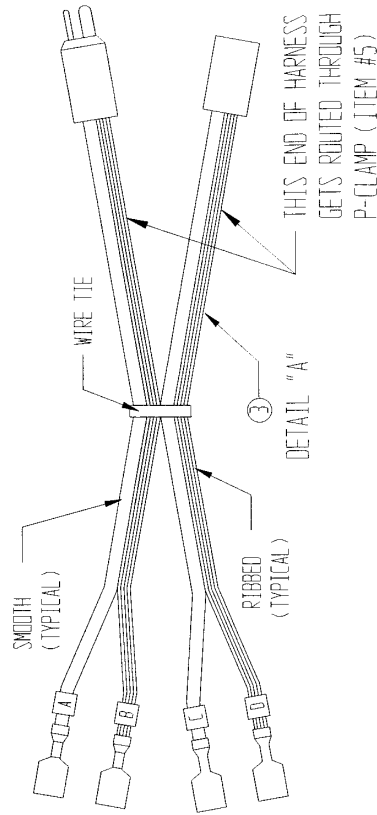
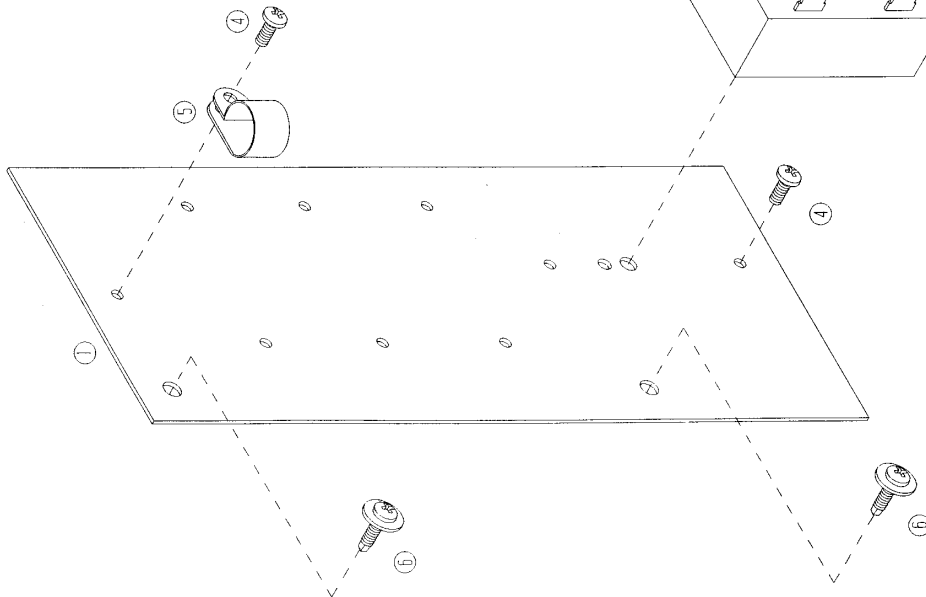

ASS'Y, CHOKE/RELAY PLATE - FOSTER

B 631.007.300.13

# WIRING DIAGRAMS AND SCHEMATICS

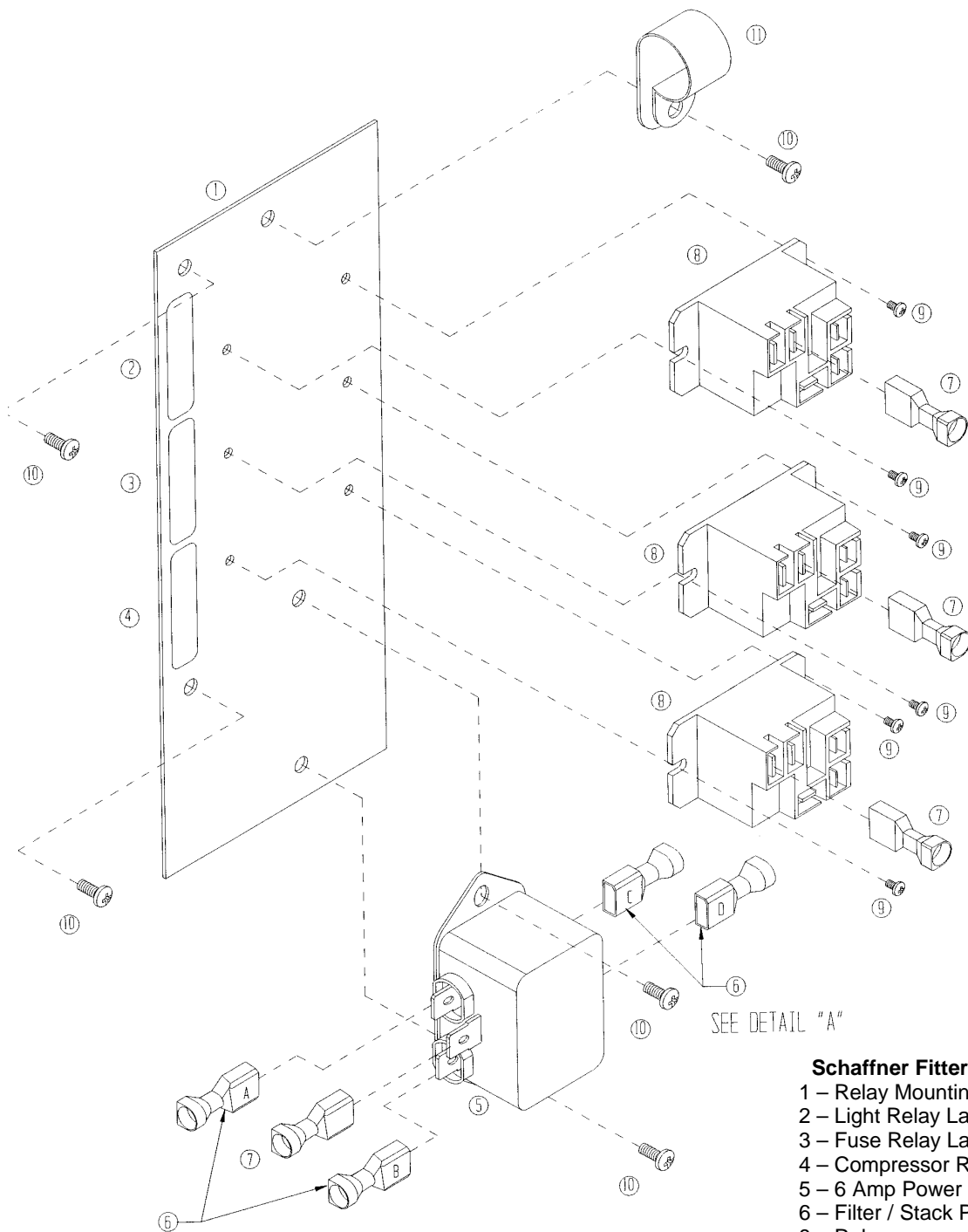

SEE DETAIL "A"

## HT2 Schaffner Fitter / Relay Plate Assy.

- 1 – Relay Mounting Plate
- 2 – Light Relay Label
- 3 – Fuse Relay Label
- 4 – Compressor Relay Label
- 5 – 6 Amp Power Line Filter
- 6 – Filter / Stack Plug Harness
- 8 – Relay
- 9 – Screw, #8-32x1/4"
- 10 – Screw, #8-32x3/8"
- 11 – Clamp, 3/4"

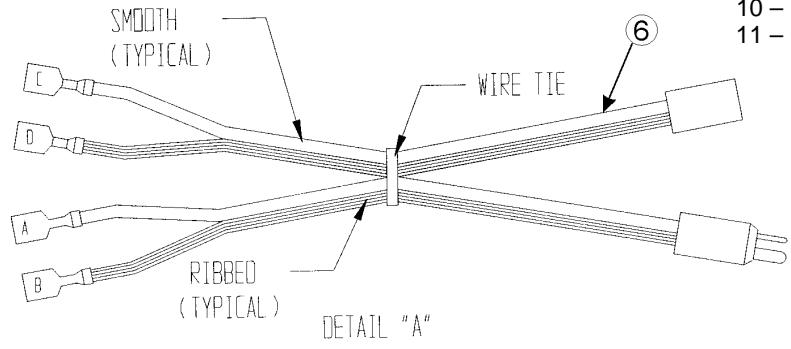

**PARTS LIST**

**MAIN DOOR PARTS (EXTERIOR)**

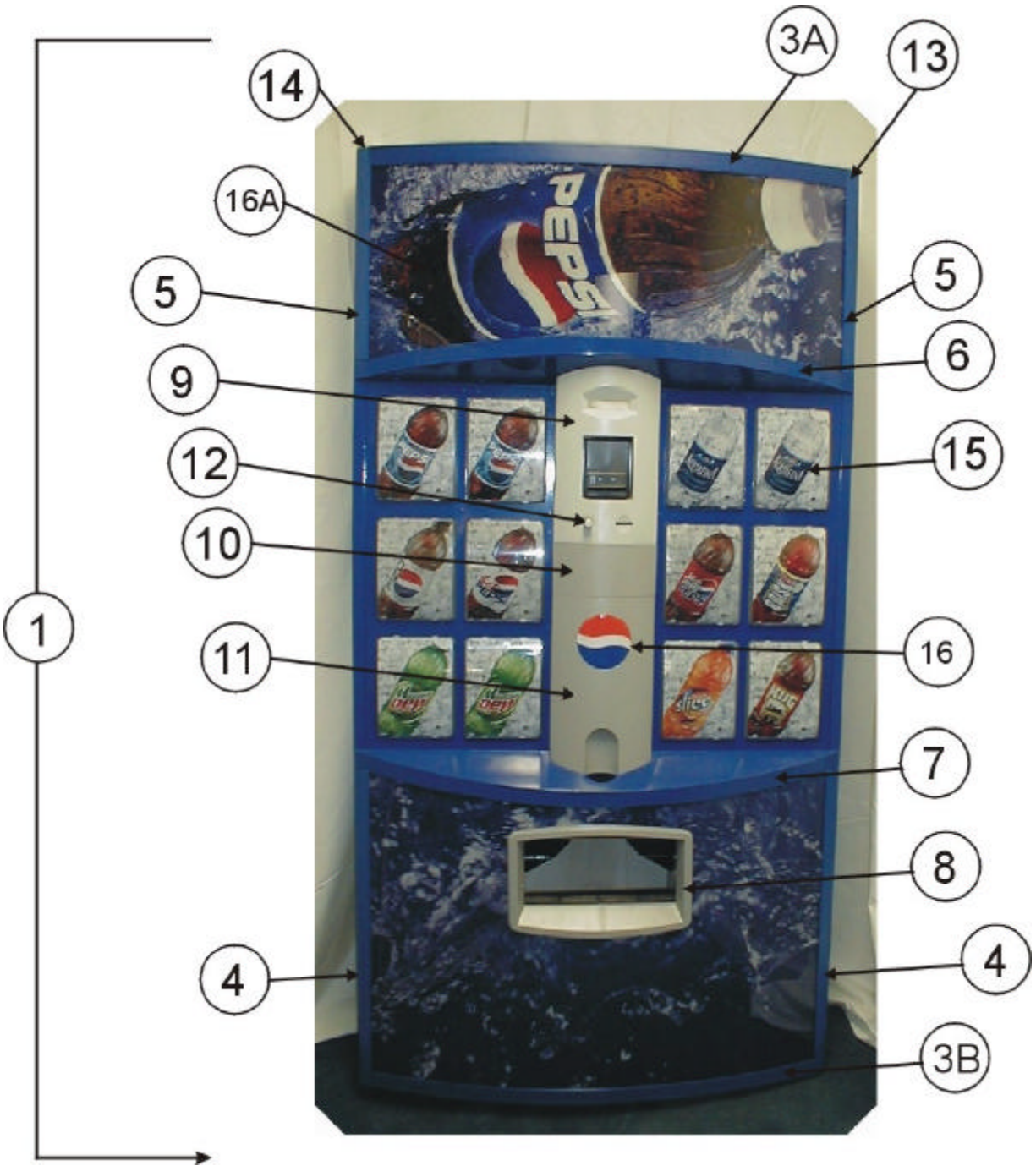

**PARTS LIST**

**MAIN DOOR PARTS (EXTERIOR)**

ITEM	PART DESCRIPTION	HT2 (501E)	HT3 (501E)
1	Main Door Assembly 501E Pepsi	631,004,40x.x3	631,050,00x.x3
	Main Door Assembly 501E Mtn. Dew	NA	631,054,70x.x3
2	Door Weld Assembly Pepsi	631,004,20x.x3	631,050,10x.x3
	Door Weld Assembly Mtn. Dew	NA	631,054,80x.x3
3A	Trim, Top Panel Cap Pepsi	631,001,23x.x3	801,814,63x.x1
	Trim, Top Panel Cap Mtn. Dew	NA	801,814,82x.x1
3B	Bottom Panel Cap Pepsi	631,002,23x.x1	801,814,75x.x1
	Bottom Panel Cap Mtn. Dew	NA	801,814,84x.x1
4	Lower Side Trim Pepsi	631,000,56x.x3	801,814,57x.x1
	Lower Side Trim Mtn. Dew	NA	631,050,53x.x1
5	Upper Side Trim Pepsi	631,000,57x.x3	801,814,61x.x1
	Upper Side Trim Mtn. Dew	NA	631,050,51x.x1
6	Top Cap Pepsi	801,813,40x.x1	801,814,64x.x1
	Top Cap Mtn. Dew	NA	801,814,86x.x1
7	Bottom Cap Pepsi	801,813,50x.x1	801,814,65x.x1
	Bottom Cap Mtn. Dew	NA	801,814,88x.x1
8	Spacer Port Trim Assembly	631,003,80x.x3	631,001,70x.x3
9	Top Column Cover	801,814,13x.x1	801,814,13x.x1
10	Center Column Cover	801,813,70x.x1	801,813,70x.x1
11	Bottom Column Cover	801,813,30x.x1	801,813,30x.x1
12	Coin Return Button	801,814,22x.x1	801,814,22x.x1
13	Top End Cap, Right	801,814,14x.x1	NA
14	Top End Cap, Left	801,814,18x.x1	NA
15	Select Button	801,814,01x.x1	801,814,01x.x1
16	Pepsi Medallion	801,813,33x.x1	803,864,94x.x1
16	Aquafina Medallion	NA	803,865,02x.x1
16	Mountain Dew Medallion	NA	803,864,95x.x1
16A	Sign, HVV (Top) Pepsi	805,030,16x.x1	805,031,33x.x1
	Sign, HVV (Top) Mtn. Dew	NA	805,031,44x.x1
16B	Sign, HVV (Bottom) Pepsi	805,030,17x.x1	805,031,34x.x1
	Sign, HVV (Bottom) Mtn. Dew	NA	805,031,46x.x1
17	Vandal Panel Pepsi	165,150,33x.x3	165,150,33x.x3
	Vandal Panel Mtn. Dew	NA	631,050,38x.x3

NA = Not Applicable  
 Part numbers subject to change without notice.

**PARTS LIST**

**MAIN DOOR INTERIOR (A)**

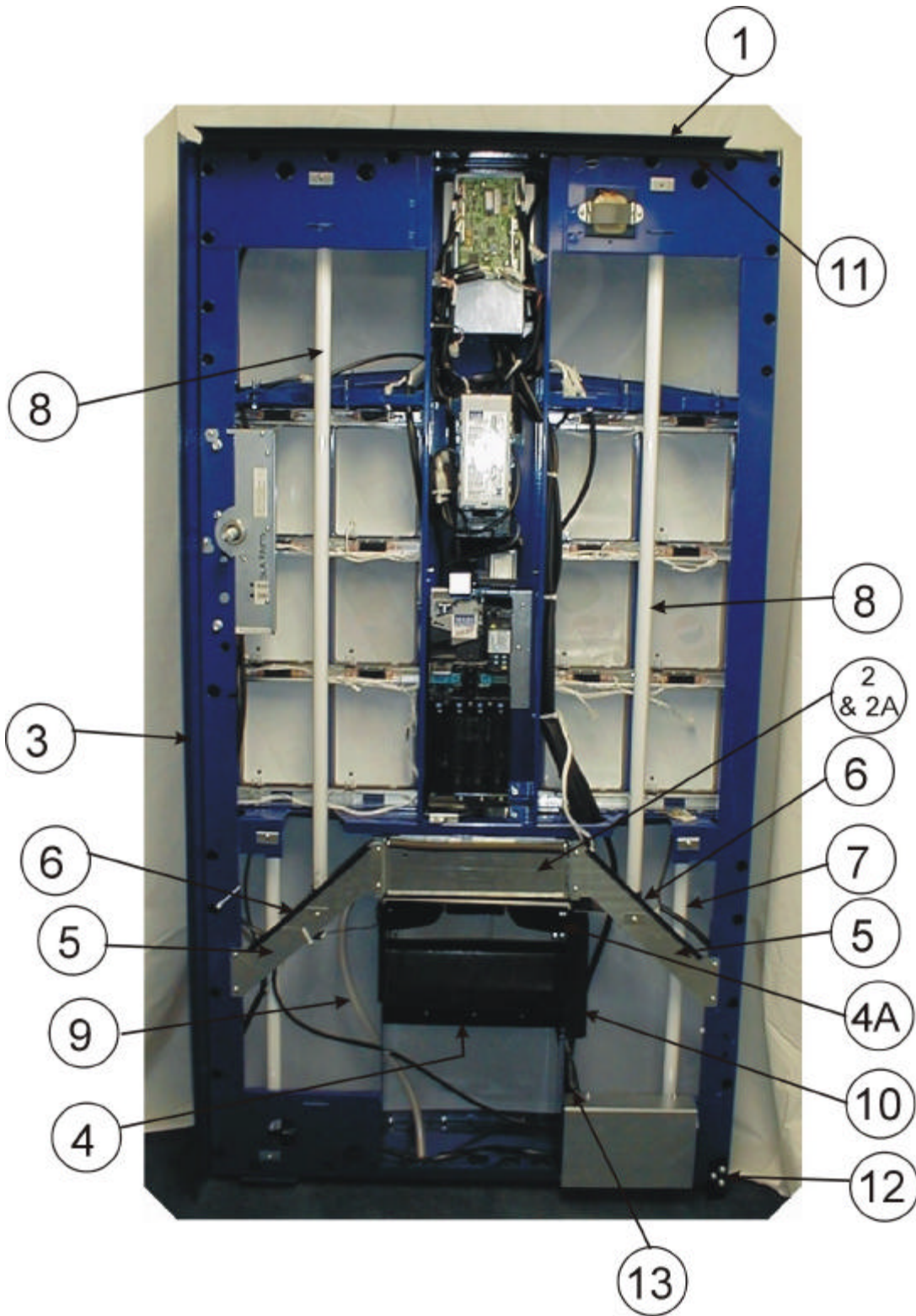

NA = Not Applicable  
Part numbers subject to change without notice.

**PARTS LIST**

**MAIN DOOR INTERIOR (A)**

ITEM	PART DESCRIPTION	HT2 (501E)	HT3 (501E)
1	Rain Guard Pepsi	164,151,14x.x3	164,151,14x.x3
	Rain Guard Mtn. Dew	NA	631,050,39x.x3
2	Cash Box	631,000,69x.x3	631,052,10x.x3
2a	Vault Enclosure	631,005,30x.x3	NA
2b	Cash Box Mount Weld Assy.	NA	631,051,10x.x3
3	Protective Plate, Door	165,150,33x.x3	165,150,33x.x3
4	Wide Delivery Port	801,810,02x.x1	801,810,02x.x1
4a	Closure Strip	609,050,14x.x3	609,050,14x.x3
5	Lamp Bracket	631,001,26x.x3	631,001,26x.x3
6	Protective Edge	801,814,28x.x1	801,814,28x.x1
7	Lamp, T8,2' F17T8/TL865	804,700,77x.x1	804,700,77x.x1
8	Lamp, T8,4' F32T8/TL865	804,700,76x.x1	804,700,76x.x1
9	Drain Hose	801,904,03x.x1	801,904,03x.x1
10	Ballast T8	804,400,59x.x1	804,400,59x.x1
11	L Profile Gasket	903,600,54x.x1	903,600,54x.x1
12	Door Stop Bracket	592,051,19x.x3	592,051,19x.x3
13	W/A Port Support	631,050,70x.x3	631,050,70x.x3

NA = Not Applicable  
 Part numbers subject to change without notice.



# PARTS LIST

## MAIN DOOR INTERIOR (B)

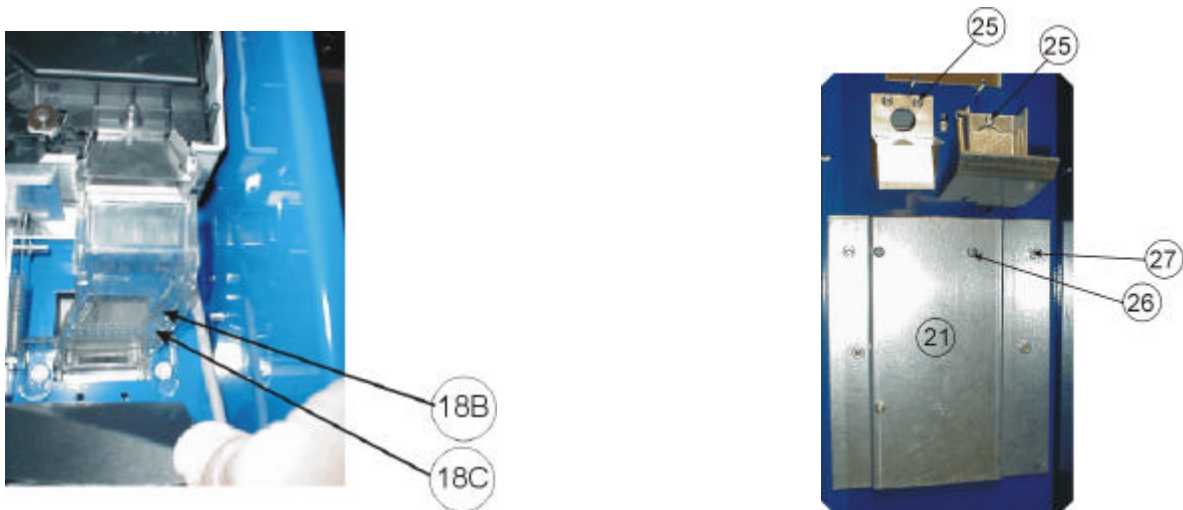
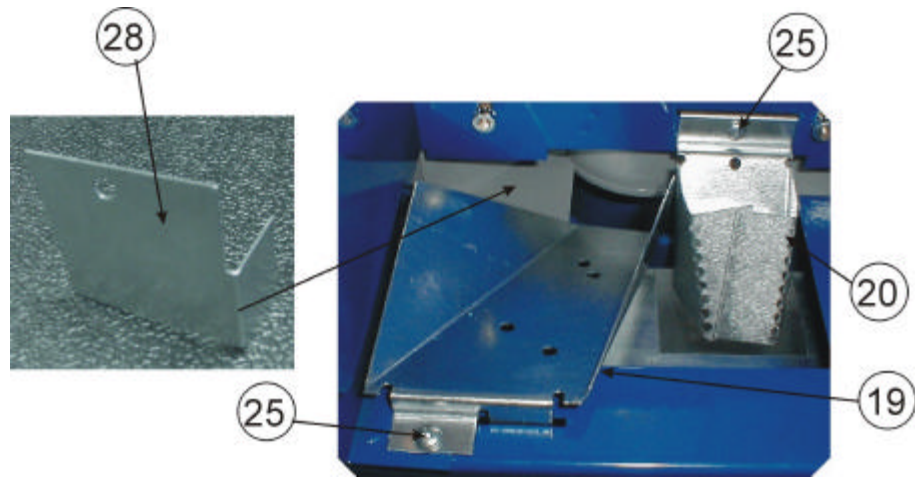
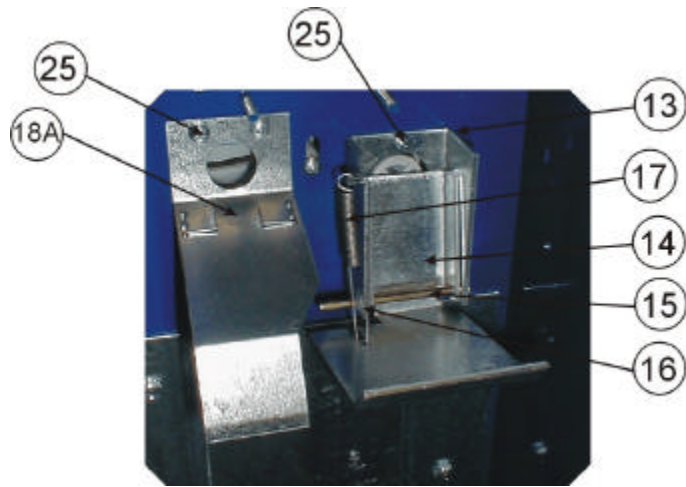

NA = Not Applicable  
Part numbers subject to change without notice.

## PARTS LIST

---

### MAIN DOOR INTERIOR (B)

ITEM	PART DESCRIPTION	HT2 (501E)	HT3 (501E)
13	Coin Return Bracket	631,001,39x.x3	631,050,18x.x3
14	Coin Return Rocker	631,001,38x.x3	631,050,17x.x3
15	Roller Pin	900,502,19x.x1	900,502,19x.x1
16	Roller Pin Retainer	900,900,90x.x1	900,900,90x.x1
17	Coin Return Spring	901,700,63x.x1	901,700,63x.x1
18A	Top Coin Chute Assembly (HT2 only)	631,005,60x.x3	NA
18B	Coin Insert Chute Cover (HT3 only)	NA	801,814,39x.x1
18C	Coin Insert Chute (HT3 only)	NA	801,814,40x.x1
19	Coin Discharge Ramp	631,001,34x.x3	801,814,35x.x1
20	Lower Coin Chute	631,001,36x.x3	801,814,36x.x1
21	Coin Mech Mounting Plate	631,001,22x.x3	631,050,13x.x1
22	Carriage Bolt, ¼ 20 x ½	900,201,45x.x1	900,201,45x.x1
23	Keps nut ¼ 20	900,800,67x.x1	900,800,67x.x1
24	Gasket, 1/8 x 1/8 x 36	801,814,27x.x1	801,814,27x.x1
25	Screw, 8-18x1/2 SD Phil Pan	900,301,50x.x1	900,301,50x.x1
26	Screw, 8-32x1/4 Phil Pan	900,301,97x.x1	900,301,97x.x1
27	Keps Nut 8-32	900,800,50x.x1	900,800,50x.x1
28	Deflector, Coin – (Metal)	631,001,44x.x3	NA

NA = Not Applicable  
Part numbers subject to change without notice.



SELECT PANEL

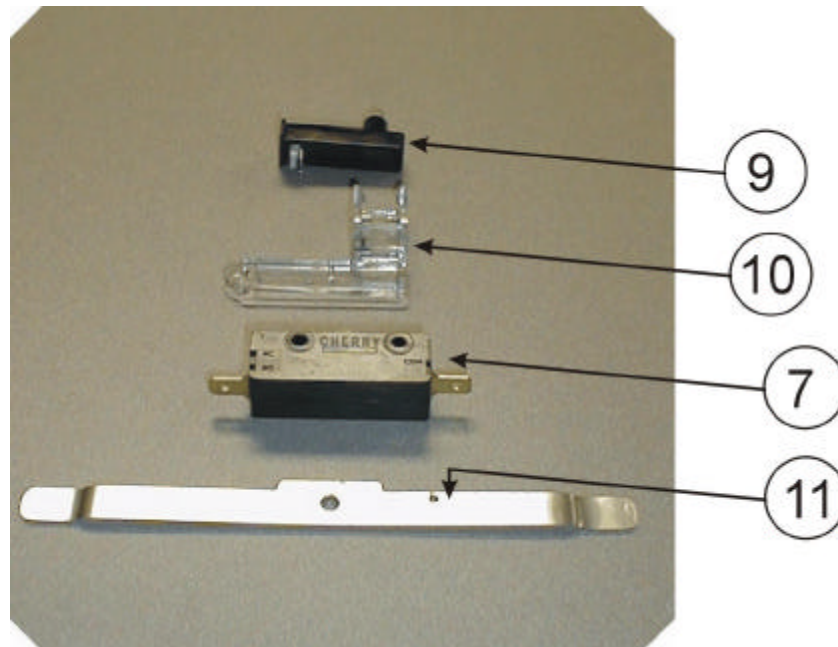
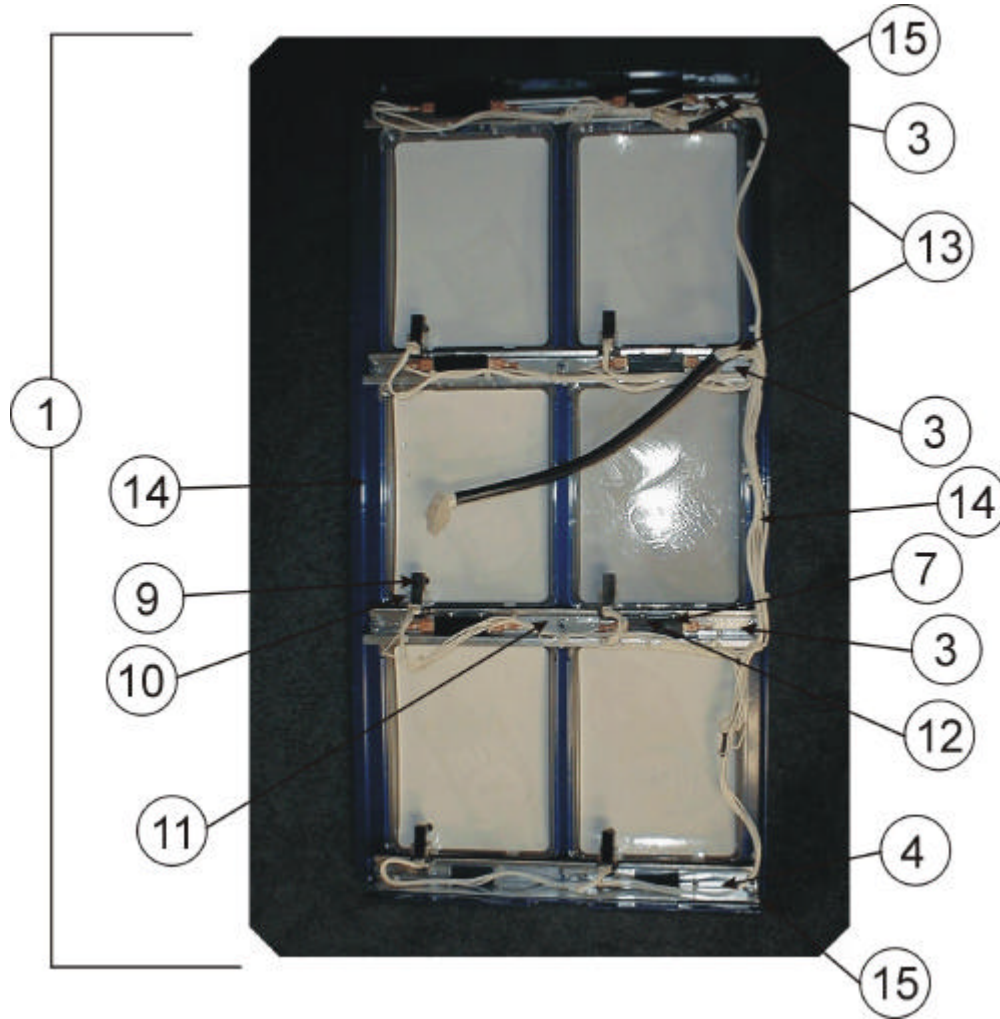

## PARTS LIST

### SELECT PANEL

ITEM	PART DESCRIPTION	HT2 (501E)	HT3 (501E)
1	Select Panel Assy., Right (shown) Pepsi	631,004,20x.x3	631,051,60x.x3
	Select Panel Assy., Right (shown) Mtn. Dew	NA	631,050,60x.x3
2	Select Panel Assy., Left (not shown) Pepsi	631,005,40x.x3	631,051,70x.x3
	Select Panel Assy., Left (not shown) Mtn. Dew	NA	631,055,10x.x3
3	Upper Switch/Button Bracket	631,001,29x.x3	631,050,16x.x3
4	Lower Switch/Button Bracket	631,001,31x.x3	NA
5	Stud Select Panel Assembly, Left Pepsi	631,005,10x.x3	631,051,90x.x3
	Stud Select Panel Assembly, Left Mtn. Dew	NA	631,055,20x.x3
6	Stud Select Panel Assembly, Right Pepsi	631,004,60x.x3	631,051,80x.x3
	Stud Select Panel Assembly, Right Mtn. Dew	NA	631,055,00x.x3
7	Select Switch	804,101,08x.x1	804,101,08x.x1
8	Select Button	801,814,01x.x1	801,814,01x.x1
9	Sold out Light	804,700,75x.x1	804,700,75x.x1
10	Sold out Light Mount	801,814,15x.x1	801,814,15x.x1
11	Button Return Spring	801,306,04x.x1	801,306,04x.x1
12	Philpan Sems Screw 6-32 x 1	800,303,35x.x1	800,303,35x.x1
13	Gasket, 1/4 x .154 x 13	801,814,25x.x1	801,814,25x.x1
14	Gasket, 1/8 x 1/8 x 27	801,814,24x.x1	NA
15	Gasket, 1/8 x 1/8 x 13.5	801,814,26x.x1	NA
16	8-32 Keps Nut	900,800,50x.x1	900,800,50x.x1
17	Wire Tie 7 1/2 "	901,902,01x.x1	901,902,01x.x1

T8 LIGHTING

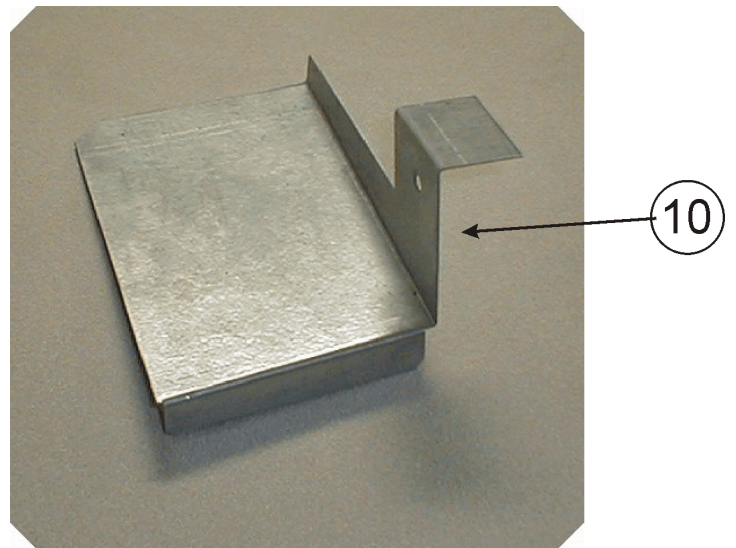
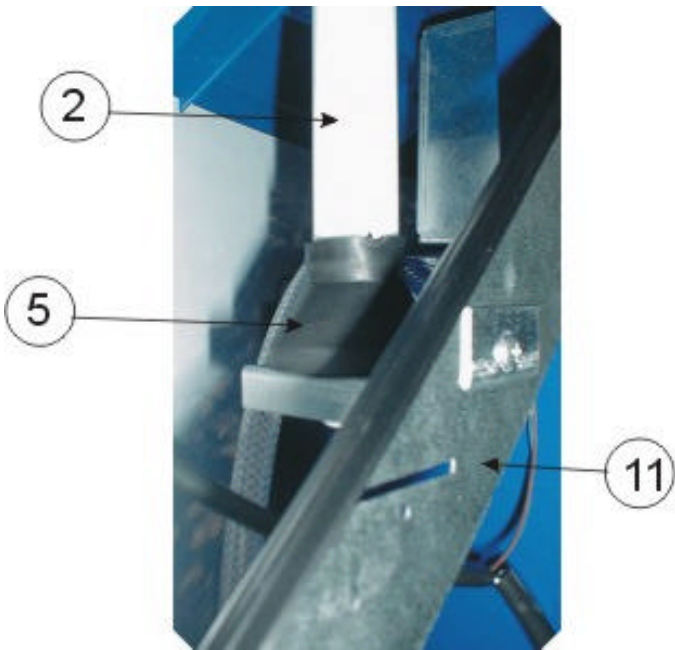
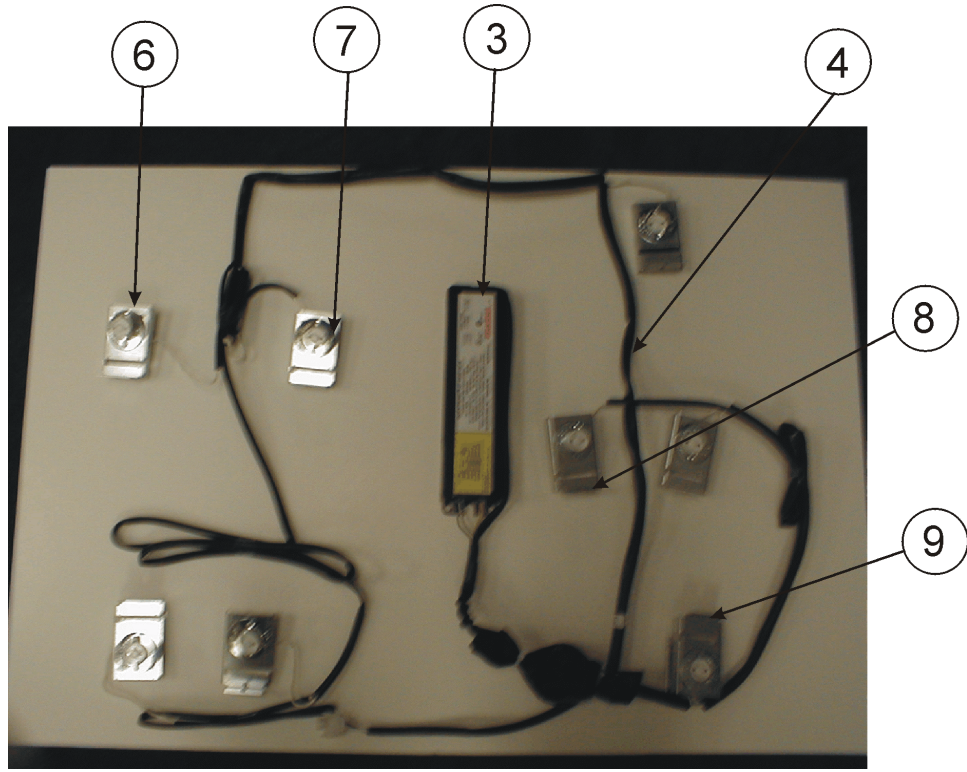

## PARTS LIST

---

### T8 LIGHTING

ITEM	PART DESCRIPTION	HT2 (501E)	HT3 (501E)
1	Fluorescent Bulb (F17T8 / TL865) 2' (Not Shown)	804,700,77x.x1	804,700,77x.x1
2	Fluorescent Bulbs (F32T8 / TL865) 4'	804,700,76x.x1	804,700,76x.x1
3	Ballast T8	804,400,59x.x1	804,400,59x.x1
4	4 Lamp T8 Lighting Harness	804,918,34x.x1	804,918,34x.x1
5	Fluorescent Lamp Boot	802,001,42x.x1	802,001,44x.x1
6	Top Lampholder T8 Leviton 518	804,918,58x.x1	804,918,58x.x1
7	Bottom Lampholder T8 Leviton 519	804,918,59x.x1	804,918,59x.x1
8	Bracket Lamp Socket (Top 6)	562,050,04x.x3	562,050,04x.x3
9	Bracket Lamp Socket (Bottom 2)	631,000,98x.x3	631,000,98x.x3
10	Ballast Cover	631,000,99x.x3	631,000,99x.x3
11	Lamp Bracket	631,001,26x.x3	631,001,26x.x3



# PARTS LIST

## ELECTRONIC COMPONENTS

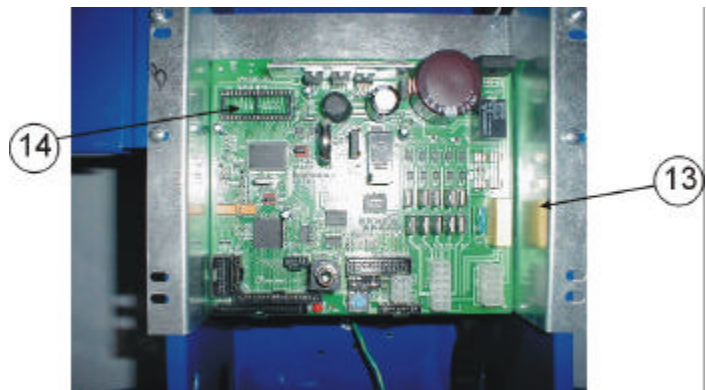
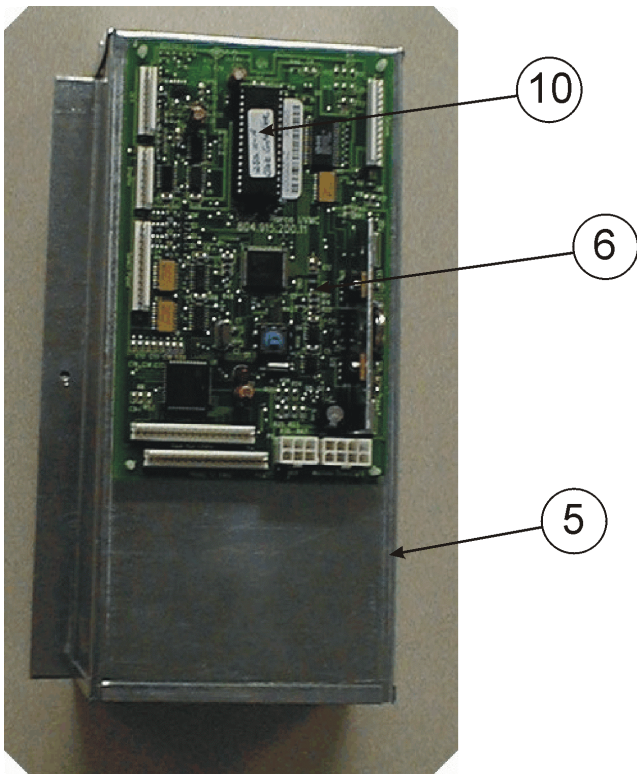
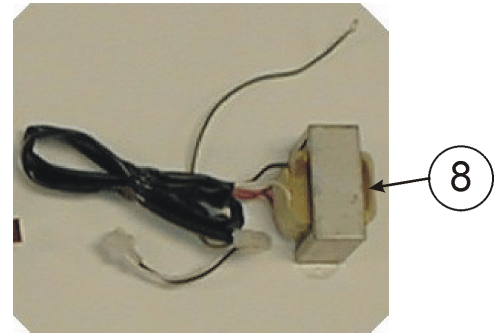
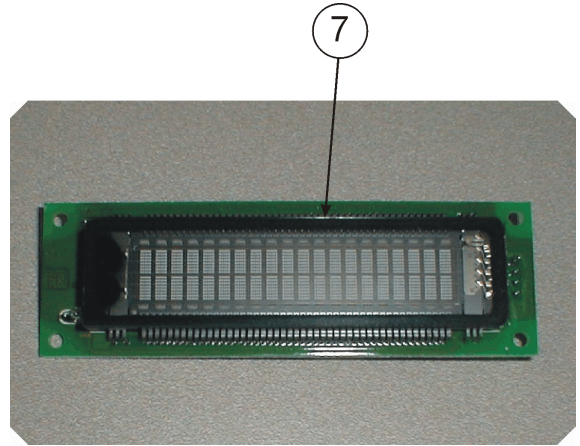
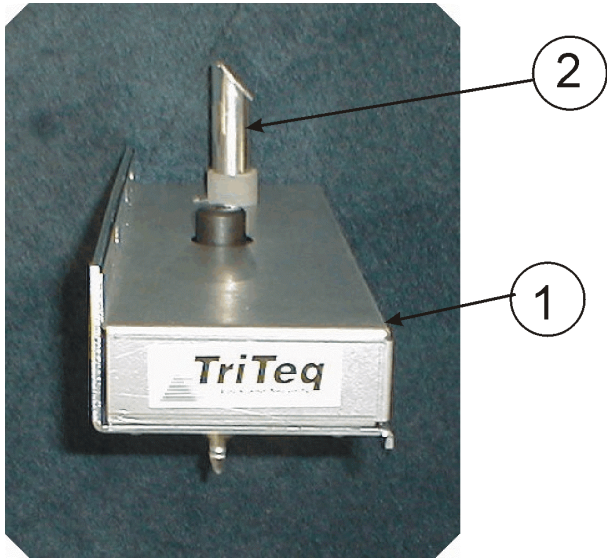

NA = Not Applicable  
Part numbers subject to change without notice.

## PARTS LIST

---

### ELECTRONICS COMPONENTS

ITEM	PART DESCRIPTION	HT2 (501E)	HT3 (501E)
1	Electronic Lock Assembly	805,202,44x.x1	805,202,44x.x1
2	Electronic Lock Light Pipe	801,814,19x.x1	801,814,19x.x1
3	Machine Controller	804,918,15x.x1	631,053,30x.x3
4	Machine Controller Base	801,813,45x.x1	801,306,15x.x1
5	Machine Controller Cover	631,000,68x.x3	801,306,16x.x1
6	Universal Controller	804,916,31x.x1	NA
7	Display (Vacuum Fluorescent)	804,918,69x.x1	804,918,69x.x1
8	Transformer	804,909,80x.x1	804,909,80x.x1
9	Machine Controller EPROM	804,917,61x.x1	NA
10	Universal Controller EPROM	804,916,25x.x1	NA
11	Fuse 6 Amp (F2)	804,910,93x.x1	804,910,93x.x1
12	Fuse 1.6 Amp (F1)	804,800,71x.x1	804,800,71x.x1
13	Control Board Assembly HT3	NA	631,053,30x.x1
14	HT3 Eprom Control Board	NA	804,919,24x.x1

NA = Not Applicable  
Part numbers subject to change without notice.

**PARTS LIST**

**INNER DOOR**

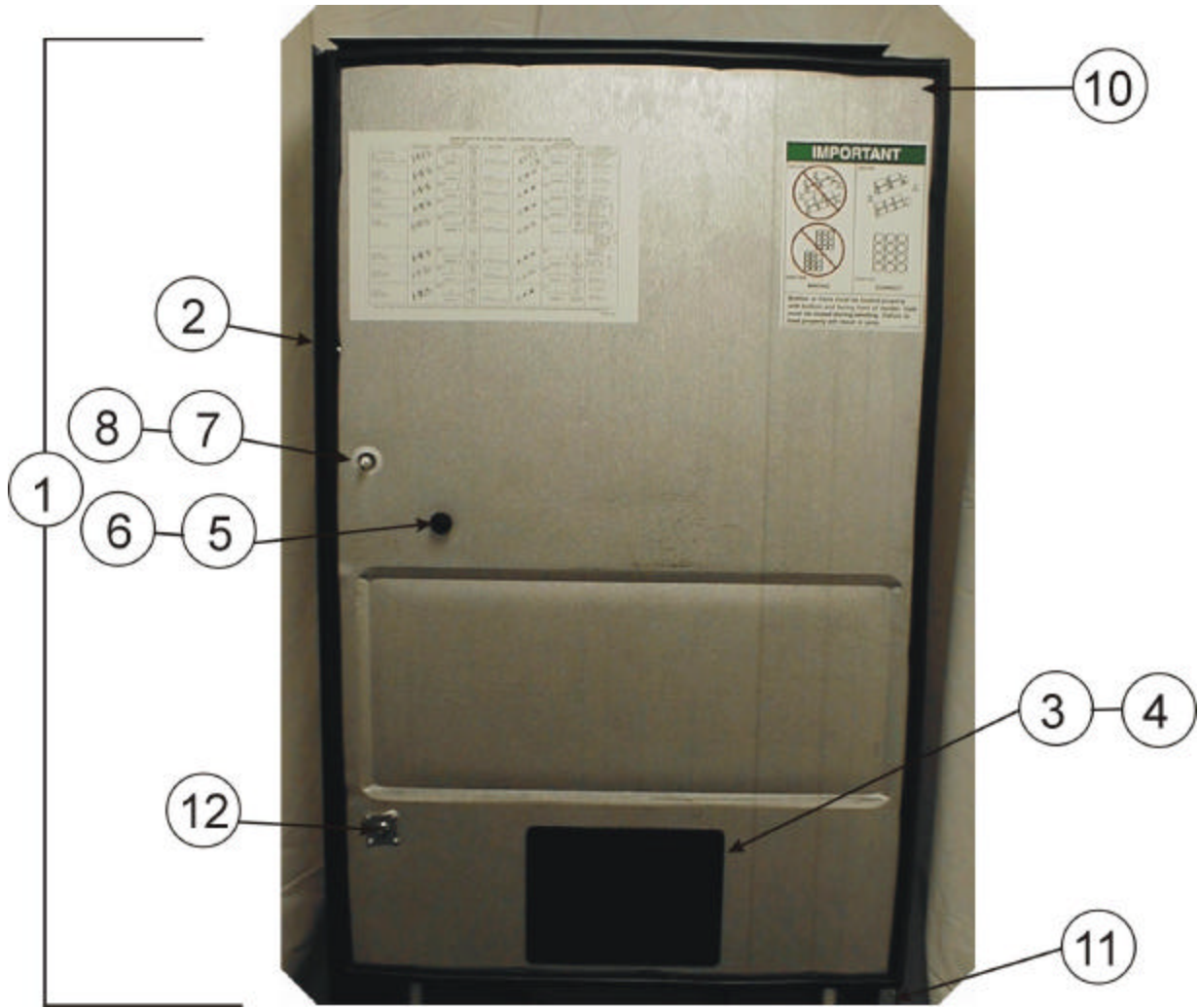

10

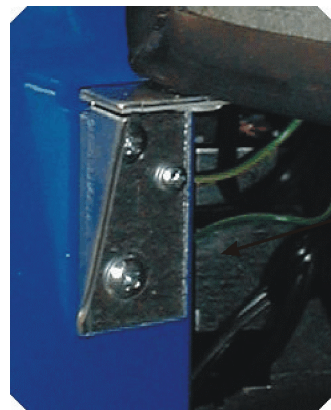

11

## PARTS LIST

---

### INNER DOOR

ITEM	PART DESCRIPTION	HT2 (501E)	HT3 (501E)
1	Inner Door Assembly	631,004,90x.x3	631,004,90x.x3
2	Inner Door Gasket	801,804,06x.x1	801,804,06x.x1
3	Discharge Frame Assembly	801,809,16x.x1	801,809,16x.x1
4	Discharge Frame Retainer	801,809,15x.x1	801,809,15x.x1
5	Pull Knob	901,501,70x.x1	901,501,70x.x1
6	Carriage Bolt 1/4x20x1/4	900,201,23x.x1	900,201,23x.x1
7	Inner Door Bushing	801,806,42x.x1	801,806,42x.x1
8	Bushing Retainer	801,806,43x.x1	801,806,43x.x1
9	Plastic Bearing	901,803,71x.x1	901,803,71x.x1
10	Top Hinge	169,053,00x.x3	169,053,00x.x3
11	Bottom Hinge	169,051,10x.x3	169,051,10x.x3
12	Inner Door Lock Kit	360,010,30x.x4	360,010,30x.x4



**PARTS LIST**

**HARNESSING  
Dual Board (HT2)**

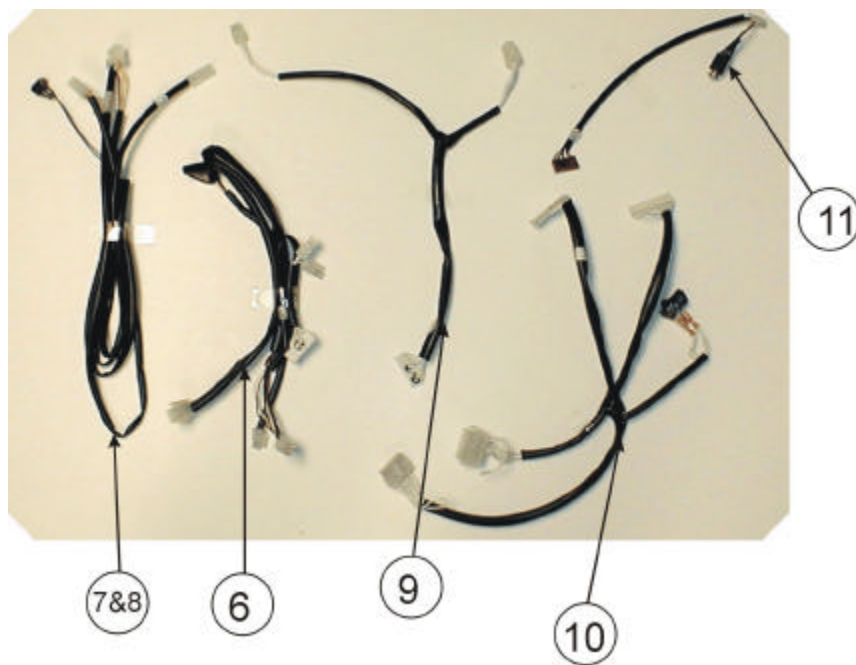
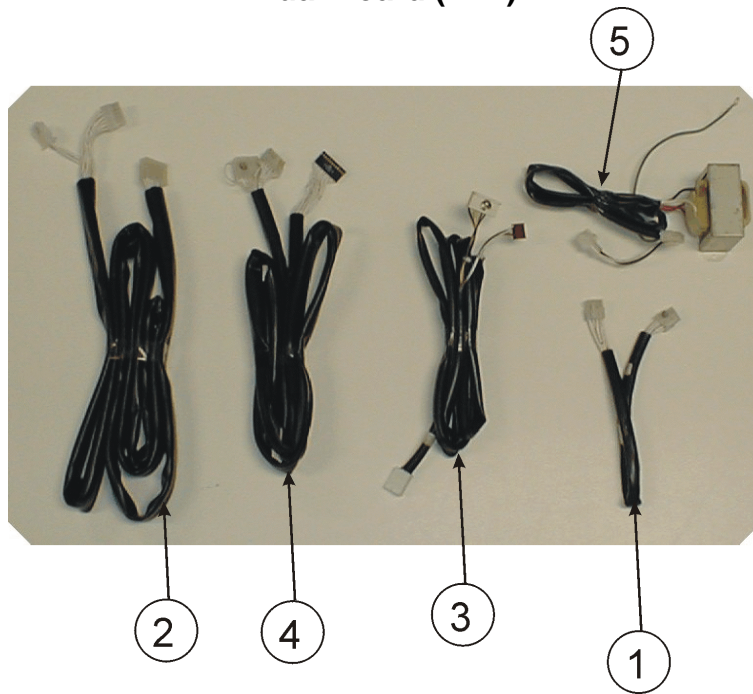

NA = Not Applicable  
Part numbers subject to change without notice.

**PARTS LIST**

**HARNESSING**

**Dual Board (HT2)**

ITEM	PART DESCRIPTION	HT2 (501E)
<b>MACHINE BOARD HARNESS</b>		
1	Board to board interface harness (J3 of machine board to J14 of universal board)	804,917,34x.x1
2	Motor Extension Harness, 90 inches (P10 to bottom of door)	804,909,29x.x1
3	Temp Sensor and Relay Extension Harness (P6 and P2 to bottom of door)	804,917,43x.x1
4	Cabinet Extension Harness, 80 inches (J1 to bottom of door)	804,913,96x.x1
5	Board Power Harness (J2 to transformer) (includes transformer)	804,909,80x.x1
<b>UNIVERSAL CONTROLLER HARNESSES</b>		
6	Mdb AND Lock Power Harness (P9 to lock and MDB peripherals)	804,918,62x.x1
7	Harness, Electronic Lock	804,918,28x.x1
8	Jumper, Electronic Lock	804,918,66x.x1
9	Select Panel Harness (P3 to select switches)	804,917,31x.x1
10	Sold Out / Ready to Vend Harness (P4 and P4A to sold out / ready to vend LED's and switch)	804,918,27x.x1
11	DEX Harness (P1 to DEX jack)	804,917,32x.x1
12	Display Harness (P2 to display board) (Not Shown)	804,918,61x.x1

**HARNESSING**  
**Single Board (HT3)**

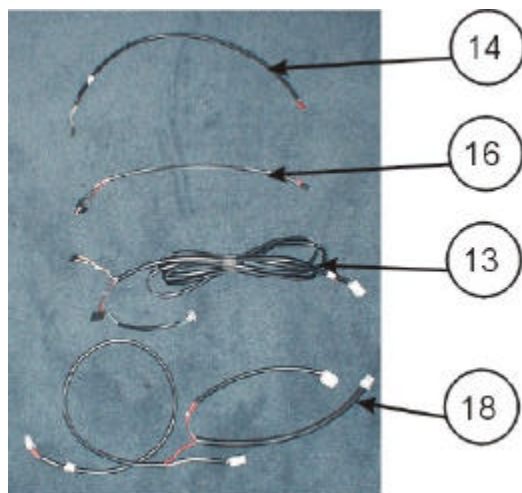
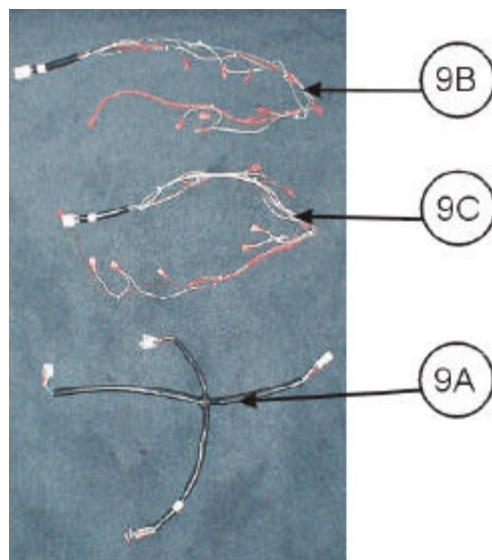

## PARTS LIST

---

### HARNESSING Single Board (HT3)

ITEM	PART DESCRIPTION	HT3 (501E)
2	Motor Extension Harness, 90" (see page 61)	804,909,29x.x1
2	Motor Harness (see page 61)	804,912,56x.x1
4	Cabinet Harness (see page 61)	804,912,57x.x1
4	Cabinet Extension Harness, 80 inches J4 to (see page 61)	804,913,96x.x1
5	Board Power Harness (including transformer) J1 (see page 61)	804,909,80x.x1
7	Harness Electronic Lock (see page 61)	804,918,28x.x1
8	Jumper Electronic Lock (see page 61)	804,918,66x.x1
9A	Select Switch Harness 1 – 6 (Jumper off common)	804,919,17x.x1
9B	Select Switch Harness 7 – 12 (Jumper off common)	804,919,18x.x1
9C	Select Switch Common Harness (P4 to select switches)	804,919,16x.x1
11	66" DEX Harness	804,907,83x.x1
13	Temp Sensor & Relay Harness	804,919,22x.x1
14	Display Harness (P3 to display board) (not shown)	804,919,21x.x1
16	Secondary DEX Harness	804,913,97x.x1
17	Sold Out Light Kit	631,053,50x.x3
18	MDB and Lock Power Harness (P8 & P5 to coin mech & lock)	804,919,19x.x1

**PARTS LIST**

**CABINET AND VEND MECHANISM  
(SECTION ONE)**

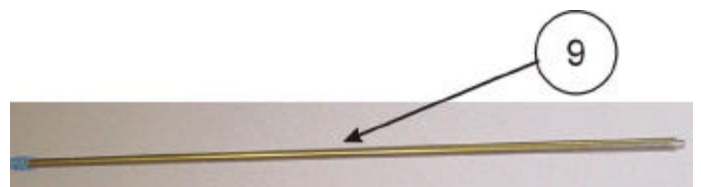
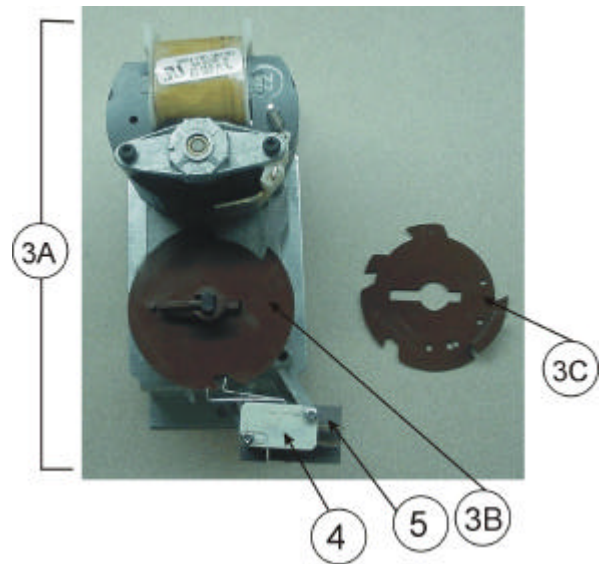
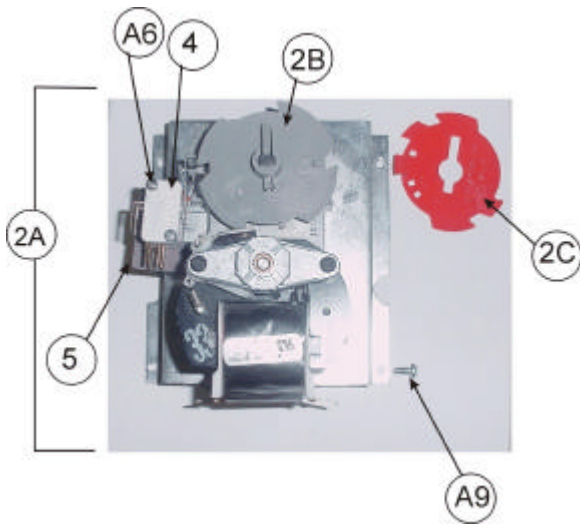
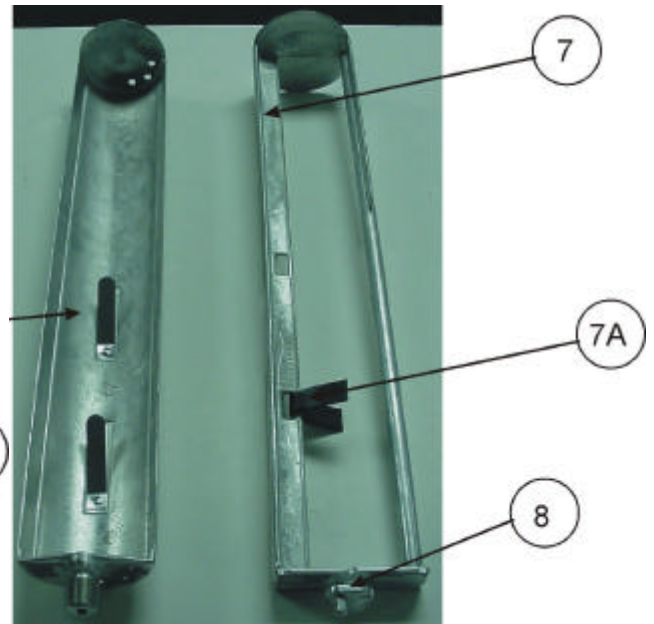
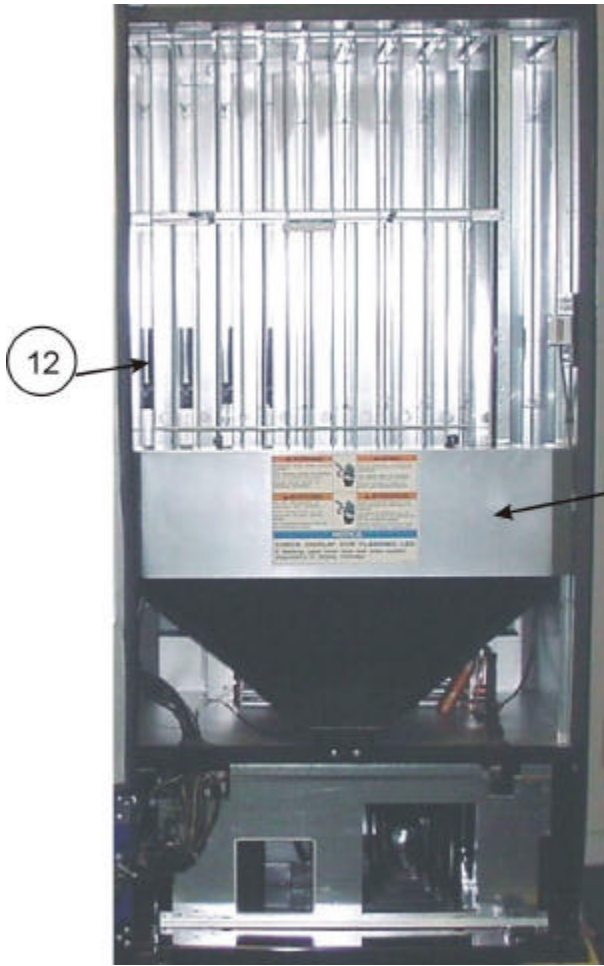

NA = Not Applicable  
Part numbers subject to change without notice.

**PARTS LIST**

**CABINET AND VEND MECHANISM  
(SECTION ONE)**

ITEM	DESCRIPTION	HT2 (501E)	HT3 (501E)
1	Vend Motor Cover Assy.	609,070,43x.x3	609,070,43x.x3
1A	Clamp Nylon Cable 3/4 (2) not shown	901,900,55x.x1	901,900,55x.x1
2A	Vend Motor Assy., Wide HVV (Electronic)	609,070,70x.x3	609,070,70x.x3
2B	Vend Cam, Wide Column Grey	801,809,80x.x1	801,809,80x.x1
2C	Adjustable Cam, Wide Column Red	801,809,79x.x1	801,809,79x.x1
3A	Vend Motor Assy., Narrow HVV (Electronic)	609,070,90x.x3	609,070,90x.x3
3B	Vend Cam, Narrow Column Brown	801,806,18x.x1	801,806,18x.x1
3C	Adjustable Cam, Narrow Column Brown	801,806,61x.x1	801,806,61x.x1
4	Vend Motor Switch Switch Electronic	804,100,73x.x1	804,100,73x.x1
5	Vend Motor Switch Insulator	905,800,33x.x1	905,800,33x.x1
6	Vend Rotor - Narrow Column	801,201,56x.x1	801,201,56x.x1
7	Vend Oscillator - Wide Column	801,201,57x.x1	801,201,57x.x1
7A	Package Retainer - Oscillator	801,807,87x.x1	801,807,87x.x1
8	Nyliner Front Wide Column Only (#8L2-FF) Rear All Columns	901,804,23x.x1 801,803,17x.x1	901,804,23x.x1 801,803,17x.x1
9	Rod and Spring Assembly	800,503,00x.x1	800,503,00x.x1
10	Tubes for Rod and Spring Assy. Red Yellow White Black	801,903,23x.x1 801,903,25x.x1 801,903,24x.x1 801,904,04x.x1	801,903,23x.x1 801,903,25x.x1 801,903,24x.x1 801,904,04x.x1
11	Vend Motor Cover Trim	801,807,85x.x1	801,807,85x.x1
12	Rear Air Deflector	801,903,29x.x1	801,903,29x.x1
A6	Screw, Vend Motor #4-24x3/4 (single switch)	900,300,47xx.1	900,300,47xx.1
A9	Screw, Phil Pan 8-32x3/8	900,301,56x.x1	900,301,56x.x1



# PARTS LIST

## CABINET AND VEND MECHANISM (SECTION TWO)

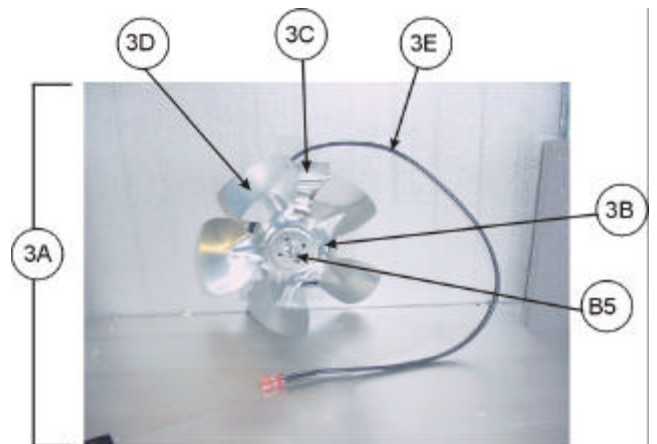
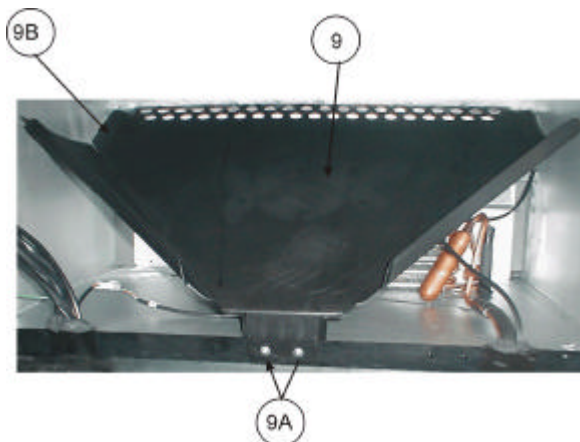
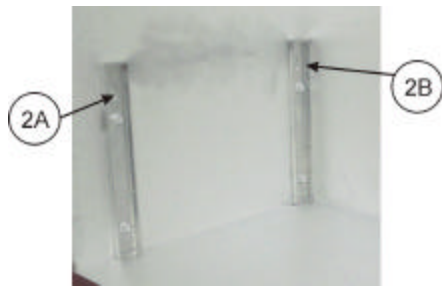
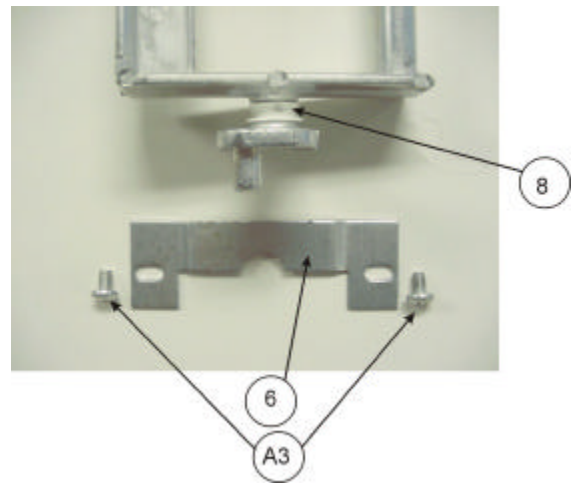
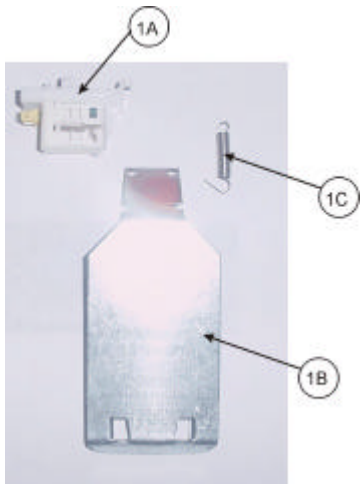
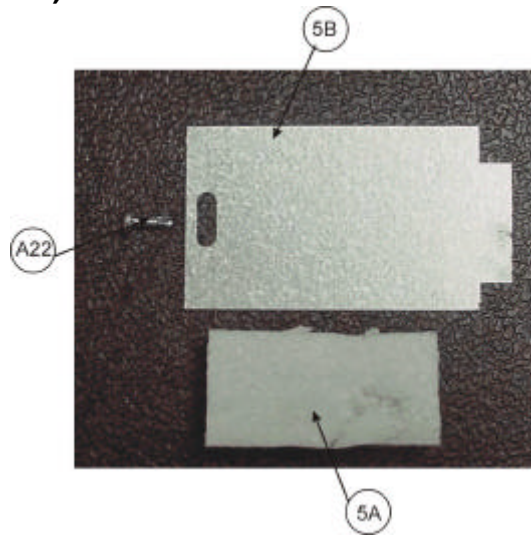
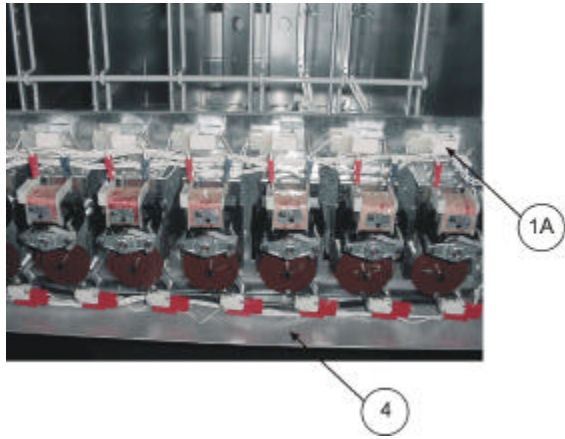

NA = Not Applicable  
Part numbers subject to change without notice.

**PARTS LIST**

**CABINET AND VEND MECHANISM  
(SECTION TWO)**

ITEM	DESCRIPTION	HT2 (501E)	HT3 (501E)
1A	Sold-Out Switch Assy. Electronic (w/ gold cross point) - Xenoy 1731	804,100,75x.x1	804,100,75x.x1
1B	Sold-Out Paddle		
	Standard Emodel (shown)	432,070,19x.x3	432,070,19x.x3
	Special Use Only - E-Models	609,070,19x.x3	609,070,19x.x3
	Narrow - Special Use Only E-Models	432,070,17x.x3	432,070,17x.x3
1C	Sold-Out Paddle Spring	901,700,74x.x1	901,700,74x.x1
2A	Front, Left Mechanism Support (shown)	609,070,22x.x3	NA
2B	Rear Mechanism Support (shown)	497,070,01x.x3	497,070,01x.x3
2C	Front, Right Mechanism Support (not shown)	609,070,23x.x3	NA
3A	Evaporator Fan Motor Assy.		
	115V	491,000,20x.x3	609,044,30x.x3
	220-240V	491,140,40x.x3	NA
3B	Evaporator Fan Motor		
	115V	609,044,40x.x3	804,501,12x.x1
	220-240V / 50 Hz	609,044,60x.x3	609,044,60x.x3
3C	Evaporator Fan Motor Bracket	164,040,08x.x3	164,040,08x.x3
3D	Evaporator Fan Blade All Styles (AD775CW32S or FV775CW30S)	801,303,27x.x1	801,303,27x.x1
3E	Evaporator Fan Harness	804,914,35x.x1	804,914,35x.x1
4	Wire Shield	267,070,37x.x3	267,070,37x.x3
5A	Foam Block, EPS	903,300,77x.x1	903,300,77x.x1
5B	Hinge Pocket Cover	169,000,13x.x3	169,000,13x.x3
6	Journal	176,072,11x.x3	176,072,11x.x3
7	Shims		
	Flat Shim 3/32" (wide column) Waffle	801,812,04x.x1	801,812,04x.x1
	Short Flat Shim 3/32" (wide column)	801,809,81x.x1	801,809,81x.x1
	Can Stop Shim, Right (narrow column)	805,701,14x.x1	805,701,14x.x1
	Bottle Shim, Right (narrow column)	805,701,15x.x1	805,701,15x.x1
	Bottle Shim, Right (narrow column) Expose Stiffener	801,304,96x.x1	801,304,96x.x1
	Angle Shim (wide column)	610,070,06x.x3	610,070,06x.x3
	Angle Shim (narrow column)	609,010,10x.x3	609,010,10x.x3
	Rotor Shim 330 ml x 4	801,305,21x.x1	801,305,21x.x1
	Shim 330 ml x 4 Can, Narrow Column	609,070,53x.x3	609,070,53x.x3
	Can Stop Shim, 330 ml (3 deep)	609,070,71x.x3	609,070,71x.x3
	Shim 25 cl x 4 Can, Narrow Column	609,070,56x.x3	609,070,56x.x3
	Bottom Shim, Exposed Stiffener Extended Lip	609,070,65x.x3	609,070,65x.x3
	Flat Shim 3/32 Large Product	801,811,05x.x1	801,811,05x.x1
	Shim Back	609,071,02x.x3	609,071,02x.x3
	Can Stop Shim Long Lip	609,070,64x.x3	609,070,64x.x3
8	Nyliner		
	Front Wide Column Only (#8L2-FF)	901,804,23x.x1	901,804,23x.x1
	Rear All Columns	801,803,17x.x1	801,803,17x.x1
9	Chute, Can/Bottle HVV Plastic	609,077,80x.x1	609,077,80x.x1
9A	Screw, 8-32x1/2 Sems Phil Pan	900,303,09x.x1	900,303,09x.x1
9B	Strip, Poly Foam 34" (under chute)	803,301,30x.x1	803,301,30x.x1
A3	Screw, Phil Pan 10-32x5/16"	900,301,83x.x1	900,301,83x.x1
B5	Speed Nut (evaporator fan & condenser fan)	900,800,85x.x1	900,800,85x.x1

NA = Not Applicable  
Part numbers subject to change without notice.



**PARTS LIST**

**CABINET AND VEND MECHANISM  
(SECTION THREE)**



NA = Not Applicable  
Part numbers subject to change without notice.

## PARTS LIST

### CABINET AND VEND MECHANISM (SECTION THREE)

ITEM	DESCRIPTION	HT2 (501E)	HT3 (501E)
1	Foam Cabinet Assy. Hvv	609,001,20x.x3	631,060,40x.x3
2A	Stack Assy.		
	12 oz. Cans	609,071,20x.x3	609,071,20x.x3
	20 oz. Bottles	609,071,50x.x3	609,071,50x.x3
	330 ml Can 4 deep	609,074,40x.x3	609,074,40x.x3
2B	Stack Sub Assy. (Not Shown)	609,071,10x.x3	609,071,10x.x3
3A	Rear Spacer Assy. Wide Column	498,071,30x.x3	498,071,30x.x3
3B	Rear Spacer Assy. Narrow Column	498,071,40x.x3	498,071,40x.x3
3C	Latch Spring		
	Wide	901,700,88x.x1	901,700,88x.x1
	Narrow	901,700,86x.x1	901,700,86x.x1
4A	Plate, Protective LS Ext. Hinge (Specify Blue)	609,000,01x.x3	594,020,14x.x3
4B	Plate, Protective RT Cab (Specify Blue)	165,000,04x.x3	165,000,04x.x3
5	Relay (Environmental Control Kit Only)		
5A	Relay (3) (Environmental Control Venders Only)	804,200,26x.x1	804,200,26x.x1
5B	Plate Mounting Relay (used on all HVV Machines)	631,000,64x.x3	631,000,64x.x3
5C	Filter (powerline) (All HT2 501E)	804,917,96x.x1	NA
5D	Choke (Used on all HVV Machines ) (replaces Filter – 5C)	804,919,09x.x1	804,919,09x.x1
6A	Label, Light Relay (Environmental Control Venders Only)	803,860,68x.x1	803,860,68x.x1
6B	Label, Fan Relay (Environmental Control Venders Only)	803,860,69x.x1	803,860,69x.x1
6C	Label, Compressor Relay (Environmental Control Venders Only)	803,860,70x.x1	803,860,70x.x1
7	Cabinet Front Stiffener Plate	594,021,10x.x3	594,021,10x.x3
8	Trim Access Hole Stiffener	801,807,10x.x1	801,807,10x.x1
9	Caterpillar Grommeting	801,809,93x.x1	801,809,93x.x1
10	Mullion	801,806,21x.x1	801,806,23x.x1
11	Mullion Cover	801,303,83x.x1	801,303,83x.x1
12	Kydex Door (not shown)	801,903,34x.x1	801,903,34x.x1
13	Choke / Relay Plate Assy.	NA	631,007,30x.x3
A4	Screw, Phil Pan 8-18x1/2	900,301,50x.x1	900,301,50x.x1
A5	Screw, Phil Pan Swage Form #8-32x1/4"	900,301,97x.x1	900,301,97x.x1
A9	Screw, Phil Pan 8-32x3/8	900,301,56x.x1	900,301,56x.x1
A10	Screw, Machine #6-32x1 1/4"	900,201,31x.x1	900,201,31x.x1
A14	Screw, Phil Pan 10-32x1 1/4	900,301,81x.x1	900,301,81x.x1
A16	Screw, Phil Pan Sems 8-18x1/2"	900,301,65x.x1	900,301,65x.x1
A17	Screw, Type F 1/4-20x5/8 (Stack Bolts)	900,302,01x.x1	900,302,01x.x1
A19	Screw, Phil Pan 10-32x5/8	900,901,51x.x1	900,901,51x.x1
A21	Screw, Phil Pan 8-18x1/2	900,301,98x.x1	900,301,98x.x1
A26	Screw, Phil Pan 8-18x3/4	800,303,15x.x1	800,303,15x.x1
B2	Keps Nut 1/4"-20	900,800,67x.x1	900,800,67x.x1
C6	Lockwasher, Shakeproof 5/8" (1132-00-00-0551)	900,700,89x.x1	900,700,89x.x1
C8	Washer, Shakeproof (4610-16-01-0551)	900,700,62x.x1	900,700,62x.x1
E9	Carriage Bolt 1/4-20x5/8	800,303,19x.x1	800,303,19x.x1
F1	Pop Rivet, Aluminum 1/4"	901,100,43x.x1	901,100,43x.x1
F5	Pop Rivet, Steel (Zinc Plated) 1/8"	901,100,61x.x1	901,100,61x.x1
F6	Pop Rivet, Aluminum 1/8"	901,100,53x.x1	901,100,53x.x1
H2	Tinnerman Clip, Fan Shroud (C5207-014-3B)	900,901,89x.x1	900,901,89x.x1
H7	Hole Plug, Snap In - 1 1/4	801,807,01x.x1	801,807,01x.x1
I6	Clamp, Nylon 5/16 Black Heyco 3355 or Dennison 10159	900,901,79x.x1	900,901,79x.x1
I7	Clamp, Nylon 1/2" Heyco 3328	900,901,80x.x1	900,901,80x.x1

NA = Not Applicable

Part numbers subject to change without notice.

# PARTS LIST

## CABINET INTERIOR

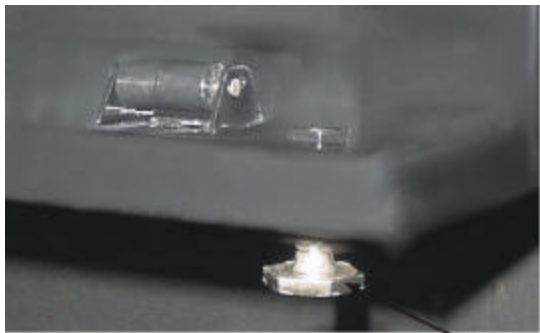

7

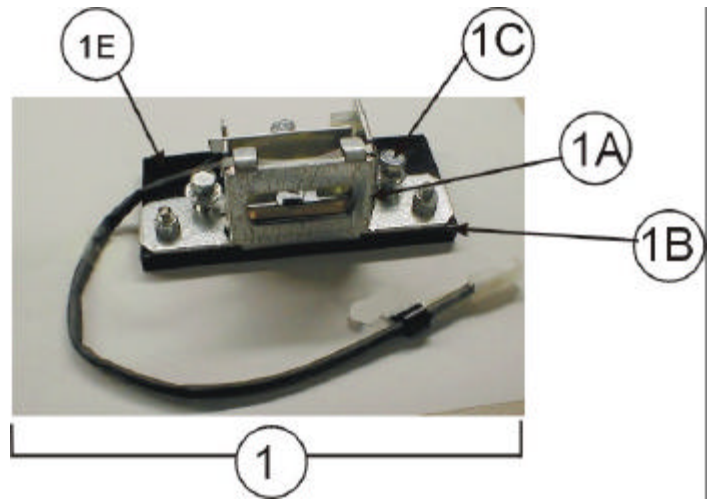

1E



5

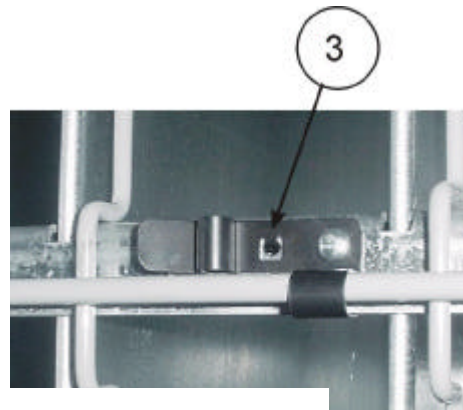

3

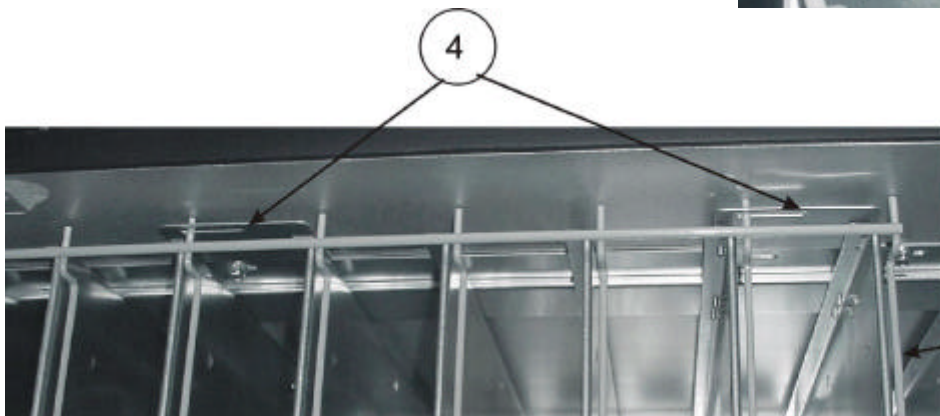

4

2

NA = Not Applicable  
Part numbers subject to change without notice.

## PARTS LIST

### CABINET INTERIOR

ITEM	DESCRIPTION	HT2 (501E)	HT3 (501E)
1	Lock Housing		
1A	Assy. Vertical Recpt Mount	631,006,40x.x3	631,006,40x.x3
1B	Plate Assy (Black)	801,306,05x.x1	801,306,05x.x1
1C	Screw 1/4x20x1	900,301,73x.x1	900,301,73x.x1
1D	Nut 1/4-20 Nylon Insert, Locking	800,303,48x.x1	800,303,48x.x1
1E	E-Lock Shim	631,000,76x.x3	631,000,76x.x3
2	Gate, Wire	801,401,72x.x1	801,401,72x.x1
3	Wire Gate Latch Lock & Guide	801,401,77x.x1	801,401,77x.x1
4	Wire Gate Bracket Top	609,070,36x.x3	609,070,36x.x3
5	Label - Close Gate	805,029,45x.x1	805,029,45x.x1
6	Clamp, Nylon Cable 1/2" (Not Shown)	900,901,80x.x1	900,901,80x.x1
7	Leveling Leg 5/8"-11x2 1/16"	900,502,49x.x1	900,502,49x.x1
8	Mounting Bracket, Rear (Not Shown)	609,070,24x.x3	609,070,24x.x3
A4	Screw, Phil Pan 8-18x1/2	900,301,50x.x1	900,301,50x.x1
A5	Screw, Phil Pan Swage Form #8-32x1/4"	900,301,97x.x1	900,301,97x.x1
A9	Screw, Phil Pan 8-32x3/8	900,301,56x.x1	900,301,56x.x1
A10	Screw, Machine #6-32x1 1/4"	900,201,31x.x1	900,201,31x.x1
A14	Screw, Phil Pan 10-32x1 1/4	900,301,81x.x1	900,301,81x.x1
A16	Screw, Phil Pan Sems 8-18x1/2"	900,301,65x.x1	900,301,65x.x1
A17	Screw, Type F 1/4-20x5/8 (Stack Bolts)	900,302,01x.x1	900,302,01x.x1
A19	Screw, Phil Pan 10-32x5/8	900,901,51x.x1	900,901,51x.x1
A21	Screw, Phil Pan 8-18x1/2	900,301,98x.x1	900,301,98x.x1
A26	Screw, Phil Pan 8-18x3/4	800,303,15x.x1	800,303,15x.x1
B2	Keps Nut 1/4"-20	900,800,67x.x1	900,800,67x.x1
C6	Lockwasher, Shakeproof 5/8" (1132-00-00-0551)	900,700,89x.x1	900,700,89x.x1
C8	Washer, Shakeproof (4610-16-01-0551)	900,700,62x.x1	900,700,62x.x1
E9	Carriage Bolt 1/4-20x5/8	800,303,19x.x1	800,303,19x.x1
F1	Pop Rivet, Aluminum 1/4"	901,100,43x.x1	901,100,43x.x1
F5	Pop Rivet, Steel (Zinc Plated) 1/8"	901,100,61x.x1	901,100,61x.x1
F6	Pop Rivet, Aluminum 1/8"	901,100,53x.x1	901,100,53x.x1
H2	Tinnerman Clip, Fan Shroud (C5207-014-3B)	900,901,89x.x1	900,901,89x.x1
H7	Hole Plug, Snap In - 1 1/4	801,807,01x.x1	801,807,01x.x1
I6	Clamp, Nylon 5/16 Black Heyco 3355 or Dennison 10159	900,901,79x.x1	900,901,79x.x1
I7	Clamp, Nylon 1/2" Heyco 3328	900,901,80x.x1	900,901,80x.x1



**PARTS LIST**

**HINGES AND ROLLER ASSY.**

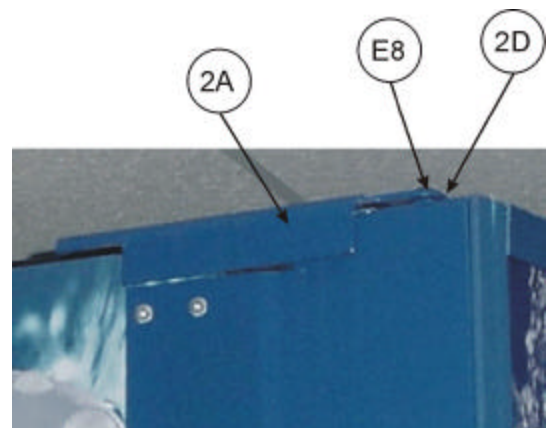
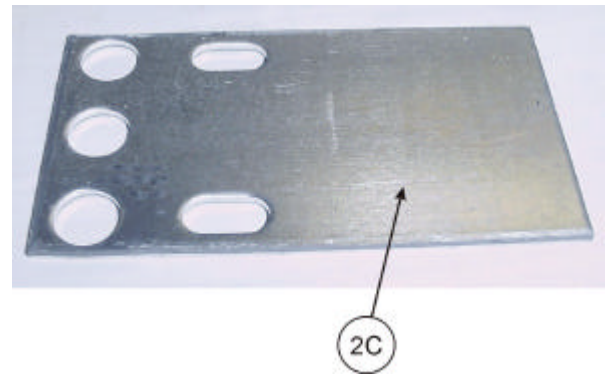
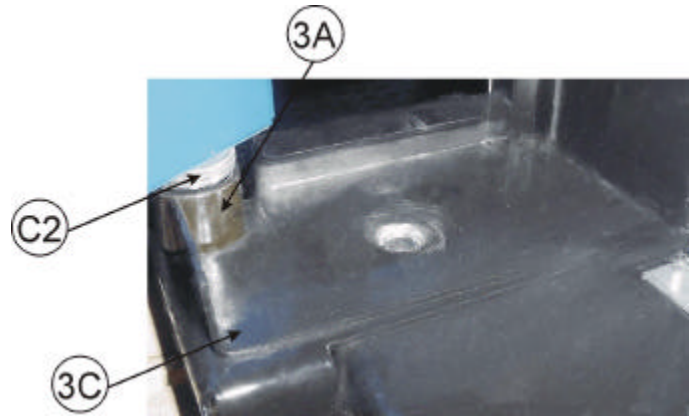
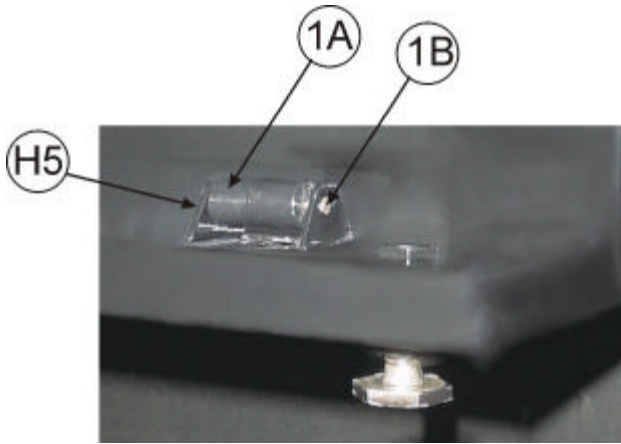

NA = Not Applicable  
Part numbers subject to change without notice.

## PARTS LIST

### HINGES AND ROLLER ASSY.

TEM	DESCRIPTION	HT2 (501E)	HT3 (501E)
1A	Roller, Main Door		
	All Styles	901,806,20x.x1	901,806,20x.x1
1B	Roller Pin		
	All Styles	900,502,19x.x1	900,502,19x.x1
2A	Assy., Top Hinge (drop in pin) E-Models		
	All Styles Pepsi	609,051,40x.x3	609,051,40x.x3
	All Styles Mtn. Dew	NA	631,055,40x.x3
2B	Top Hinge (drop in pin) E-Models		
	All Styles	801,304,92x.x1	801,304,92x.x1
2C	Top Hinge Spacer		
	All Styles	169,000,15x.x3	169,000,15x.x3
2D	Bearing Sleeve		
	All Styles	805,300,42x.x1	805,300,42x.x1
3A	Bottom Hinge Sleeve		
	All Styles	900,502,64x.x1	900,502,64x.x1
3B	Bottom Hinge Pin		
	Pepsi	900,502,70x.x1	900,502,70x.x1
3C	Bottom Hinge Assy. Cabinet		
	Pepsi	801,304,90x.x1	801,305,07x.x1
4A	Door Stop Pepsi	NA	631,001,43x.x3
	Door Stop Mtn. Dew	NA	631,050,42x.x3
4B	Door Stop Bracket Pepsi	NA	592,051,19x.x3
	Door Stop Bracket Mtn. Dew	NA	631,050,41x.x3
A9	Screw, Phil Pan Swage Form #8-32x3/8"	900,301,56x.x1	900,301,56x.x1
A15	Screw, Machine Truss #10-32x1/2"	900,201,14x.x1	900,201,14x.x1
A17	Screw, Self Tapping 1/4-20x5/8"	900,302,01x.x1	900,302,01x.x1
B2	Keps Nut, 1/4-20	900,800,67x.x1	900,800,67x.x1
B4	Keps Nut, Top Door Hinge 3/8-16	900,800,69x.x1	900,800,69x.x1
B10	Hex Nut, 5/16-28 Center w/Flange (top hinge - drop in)	900,801,02x.x1	900,801,02x.x1
C2	Flat Washer Door Hinge (Bottom)	901,303,77x.x1	901,303,77x.x1
C10	Washer, Flat 18 Gauge	900,700,83x.x1	900,700,83x.x1
C11	Flat Washer, 14 Gauge 5/16"-3/8"x7/8"	900,700,08x.x1	900,700,08x.x1
E2	Carriage Bolt, 1/4-20x1 (Top Hinge)	900,201,17x.x1	NA
E6	Carriage Bolt 1/4-20x3/4"	900,201,56x.x1	900,201,56x.x1
E8	Carriage Bolt, 1/4-20x1 1/4 (top hinge - drop in)	900,201,85x.x1	900,201,85x.x1
E9	Carriage Bolt, 1/4-20x5/8"	800,303,19x.x1	800,303,19x.x1
	Carriage Bolt, 1/4-20x1 1/4 (top hinge)	NA	900,201,23x.x1
H5	Retainer, Roller Pin	900,900,90x.x1	900,900,90x.x1

NA = Not Applicable  
Part numbers subject to change without notice.

# PARTS LIST

## REFRIGERATION SYSTEM (SECTION ONE)

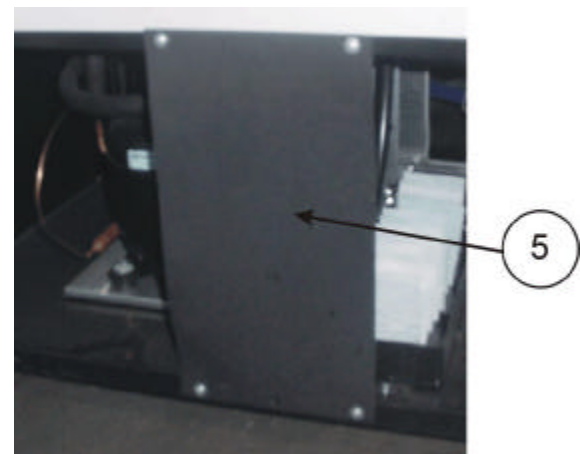
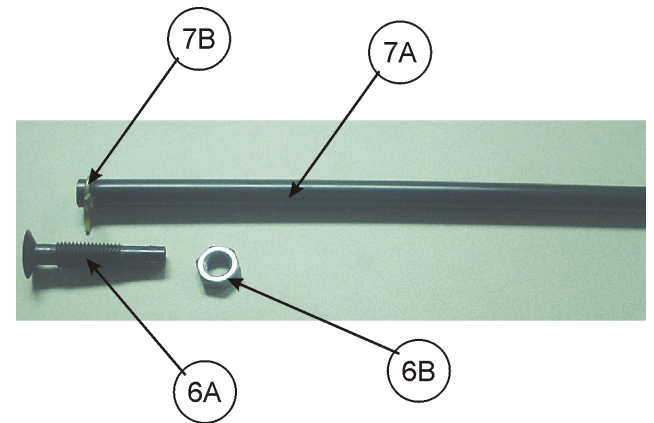
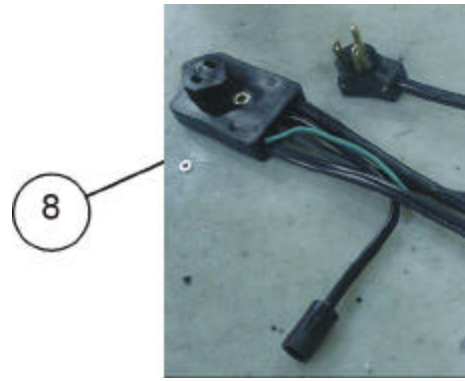
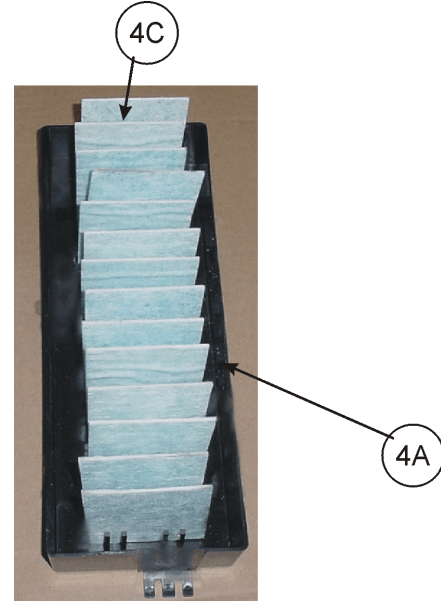
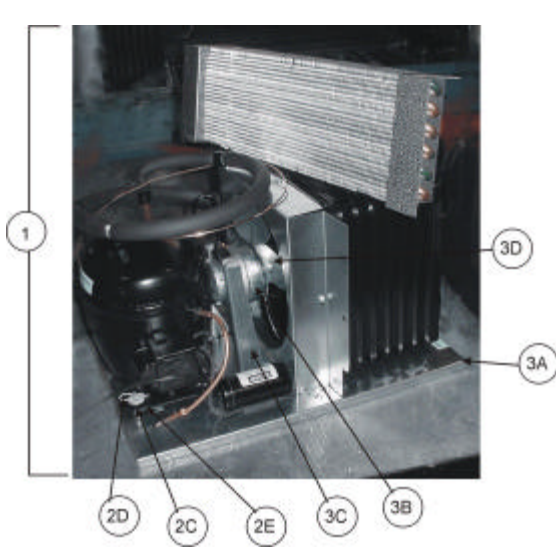

NA = Not Applicable  
Part numbers subject to change without notice.

## PARTS LIST

### REFRIGERATION SYSTEM (SECTION ONE)

ITEM	DESCRIPTION	HT2 (501E)	HT3 (501E)
1	Complete Refrigeration System		
	Domestic 1203 C-E 115/60	609,043,50x.x4	609,043,50x.x4
	1/3 HP 220-240/50 "E" (1222B-E IEC)	609,040,20x.x3	609,040,20x.x3
	1/3 HP 220-240/50 "E" (1222B-E AUS)	609,040,30x.x3	609,040,30x.x3
	1/3 HP 220-240/50 "E" (1222B-E GEN)	609,040,40x.x3	609,040,40x.x3
2A	Compressor		
	FFI12HBX 115/60 1/3 HP	802,501,74x.x1	802,501,74x.x1
	FFI12HBK 220/50 1/3 HP	802,502,17x.x1	802,502,17x.x1
2B	Compressor Lead Harness (Not Shown)		
	115/60 (1202CB-E)	904,900,61x.x1	904,900,61x.x1
	Europe (1222B-E IEC)	804,905,32x.x1	804,905,32x.x1
	IECA (1222B-E AUS)	804,904,49x.x1	804,904,49x.x1
	220/50 (1222B-E GEN)	904,900,61x.x1	904,900,61x.x1
2C	Compressor Mounting Grommet (Black)	902,000,57x.x1	902,000,57x.x1
2D	Compressor Mounting Clip	900,901,88x.x1	900,901,88x.x1
2E	Compressor Grommet Plug, Plastic	901,803,91x.x1	901,803,91x.x1
3A	Condenser Base Plate	491,040,25x.x3	491,040,25x.x3
3B	Condenser Fan Motor Assy.		
	115/60	491,040,20x.x3	491,040,20x.x3
	220/50	491,140,30x.x3	491,140,30x.x3
3C	Condenser Fan Motor Bracket ("A" Frame)		
	115/60	804,500,67x.x1	804,500,67x.x1
	220/50	804,500,70x.x1	804,500,70x.x1
3D	Condenser Fan Blade		
	All Styles FY870CW25S	800,103,37x.x2	800,103,37x.x2
4A	Drain Pan Assy. w/ Fiberglass Soakers	491,000,10x.x3	805,800,71x.x1
4B	Drain Pan, Plastic w/ Fingers (Not Shown)	801,804,24x.x1	801,804,24x.x1
4C	Soakers, Fiberglass (14 required)	905,800,69x.x1	905,800,69x.x1
5A	Ingress Guard	594,041,40x.x3	594,041,40x.x3
5B	Rear Condensate Plate	801,903,52x.x1	801,903,52x.x1
6A	Drain Tube	801,806,05x.x1	801,806,05x.x1
6B	Drain Tube Nut	900,301,79x.x1	900,301,79x.x1
7A	Drain Hose	901,900,50x.x1	901,900,50x.x1
7B	Drain Hose Clamp	900,901,03x.x1	900,901,03x.x1
8	Main Wiring Harness (Detachable)		
	United States & Mexico	804,902,22x.x1	804,917,26x.x1
9	Power Cord (Detachable)	804,917,28x.x1	804,917,28x.x1



**PARTS LIST**

**REFRIGERATION SYSTEM  
(SECTION TWO)**

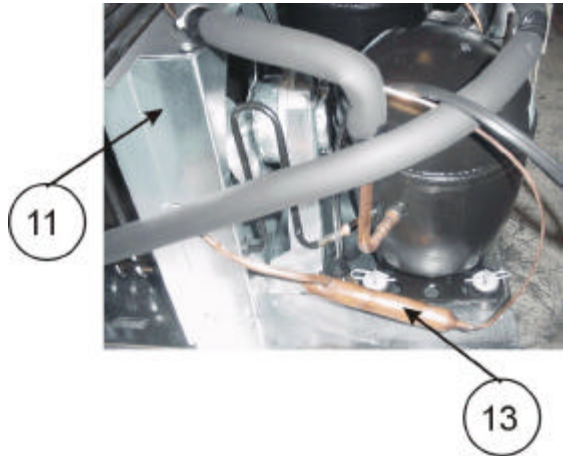
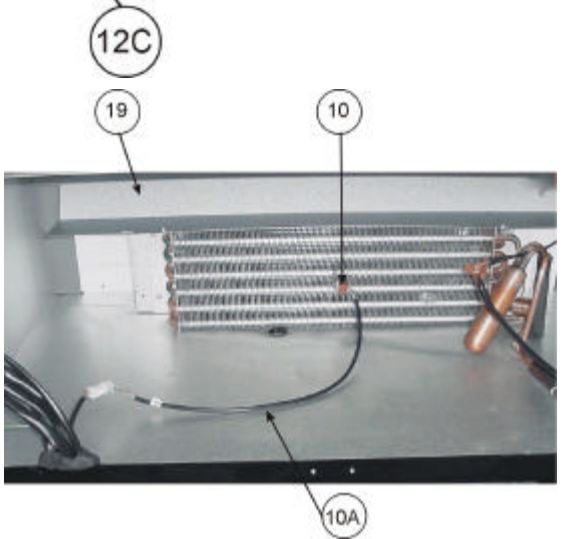
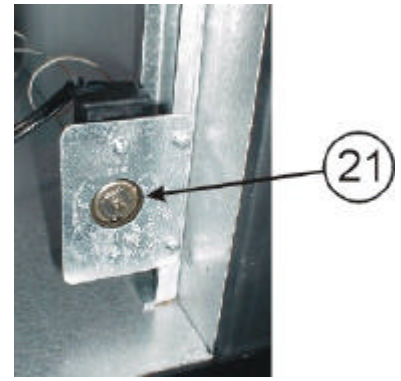
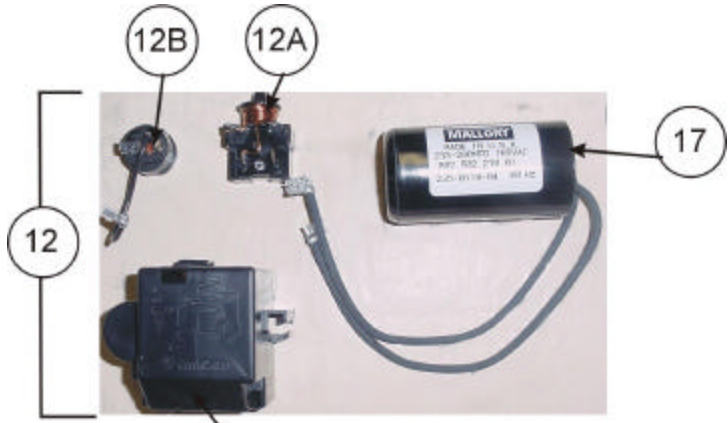
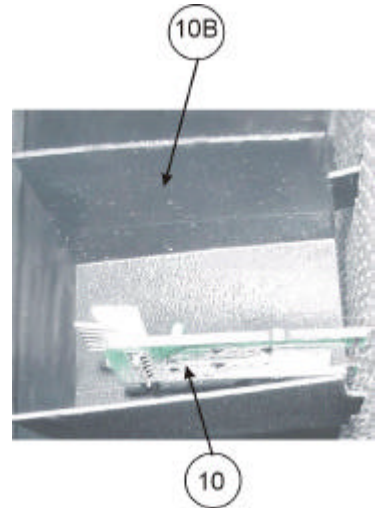
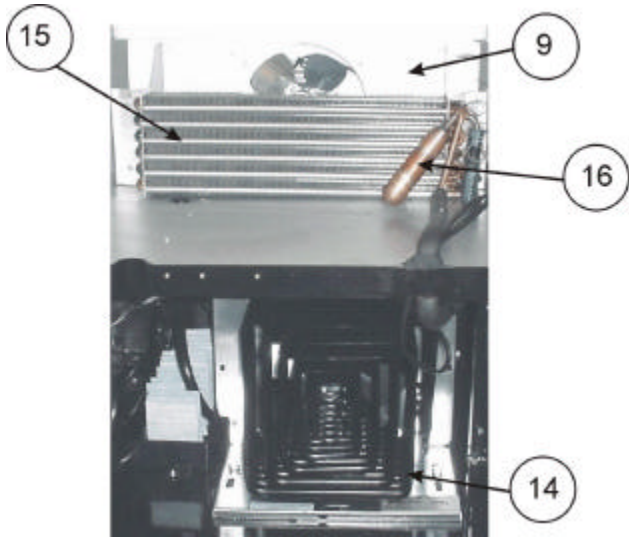

NA = Not Applicable  
Part numbers subject to change without notice.

**PARTS LIST**

**REFRIGERATION SYSTEM  
(SECTION TWO)**

ITEM	DESCRIPTION	HT2 (501E)	HT3 (501E)
9	Fan Housing Assy.		
	Assy., Housing Fan (Wide)	609,044,80x.x1	609,044,80x.x1
10	Temperature Sensor (Board)	804,917,44x.x1	804,917,44x.x1
10A	Temp Sensor Harness	804,917,41x.x1	804,917,41x.x1
10B	Cover, Temp Sensor HVV	631,001,42x.x3	631,001,42x.x3
11	Condenser Fan Shroud	491,040,11x.x3	491,040,11x.x3
12	Overload – Relay Cover Assy.		
	Domestic	802,501,77x.x1	802,501,77x.x1
12A	Relay		
	Domestic Models Embraco 1.351.605	802,502,13x.x1	802,502,13x.x1
12B	Overload		
	Domestic Models	802,502,10x.x1	802,502,10x.x1
12C	Cover	802,501,86x.x1	802,501,86x.x1
13	Dryer		
	.054 Outlet 4AXH7	802,401,29x.x1	802,401,29x.x1
14	Condenser		
	“B” 1/3 HP	802,600,55x.x1	802,600,55x.x1
15	Evaporator (short)		
	CW01655 (1/3 HP)	802,600,37x.x1	802,600,37x.x1
16	Accumulator		
	1/3 HP	802,400,46x.x1	802,400,46x.x1
17	Capacitor, Start		
	Domestic, 233-280MFD / 115V 60 Hz (FOR 1/3 HP)	802,501,21x.x1	802,501,21x.x1
17A	Capacitor, End Cap Bottom Hole (Not Shown)		
	Domestic	802,501,18x.x1	802,501,18x.x1
17B	Capacitor Assembling Bracket (Not Shown)		
	Domestic	802,501,87x.x1	802,501,87x.x1
18	Cover, Embraco (Not Shown)		
	x.x5x.x04 Short (Domestic) – 1/3 HP	802,501,86x.x1	802,501,86x.x1
	x.x5x.x00 Long (220/50) – 1/3 HP	802,501,95x.x1	802,501,95x.x1
19	Top Evaporator Cover	609,050,06x.x3	609,050,51x.x3
20	Temp Control Plate	NA	491,070,08x.x3
21	GE Temp Control	NA	802,800,58x.x1
22	Silencer	902,100,29x.x1	902,100,29x.x1

# PARTS LIST

## MISC. LABELS

ITEM	DESCRIPTION	HT2 (501E)	HT3 (501E)
1	Labels		
	Price Label Sheet	803,861,87x.x1	803,861,87x.x1
	HVV Programming (English)	803,862,08x.x1	803,862,08x.x1
	Package Set-Up Guide Domestic (Non Coke)	803,849,11x.x1	803,849,11x.x1
	Label, Light Relay	803,860,68x.x1	803,860,68x.x1
	Label, Fan Relay	803,860,69x.x1	803,860,69x.x1
	Label, Compressor Relay	803,860,70x.x1	803,860,70x.x1
	Close Gate Sign	805,029,45x.x1	805,029,45x.x1
	Warning: Do Not Tilt	803,843,64x.x1	803,843,64x.x1
	134A Removable Substance	903,833,54x.x1	903,833,54x.x1
	Money Removed Daily	903,805,70x.x1	903,805,70x.x1
	Power Disconnect, Warning	803,857,01x.x1	803,857,01x.x1
	Power Supply Cord Label	803,834,65x.x1	803,834,65x.x1
	Skid Removal	903,828,70x.x1	903,828,70x.x1
	Coin Mechanism Label	803,863,59x.x1	803,863,59x.x1
	Fuses F1-lamp, F2-6A	803,843,91x.x1	803,843,91x.x1
	Mercury Notice Label	803,860,59x.x1	803,860,59x.x1
	Notice - No Refund Label	803,860,53x.x1	803,860,53x.x1
	Sold Out / Ready to Vend Light Switch Label	803,863,63x.x1	803,863,63x.x1
	Motor Cover Label	803,863,09x.x1	803,863,09x.x1
	Button & Stack Label	803,863,61x.x1	803,863,61x.x1
	Motor Cover Label	803,863,09x.x1	803,863,09x.x1
	Button & Stack Label	803,863,61x.x1	803,863,61x.x1
2	Wiring Diagram HVV Pepsi – 12 Select	803,863,07x.x1	803,864,29x.x1
3	Pepsi Domestic Bottle Side Decal 72x25.25	803,861,85x.x1	803,861,85x.x1
4	Installation & Setup Guide	903,901,60x.x1	903,901,60x.x1
5	Technical Manual	803,903,12x.x1	803,903,12x.x1

## PARTS LIST

---

### DOMESTIC SIGNS & SIDE DECALS (Contact Parts Department for any not listed)

ITEM	DESCRIPTION	HT2 (501E)	HT3 (501E)
3	Pepsi Side Decals		
	Pepsi Domestic Bottle 72 x 25.25	803,861,85x.x1	803,861,85x.x1
	Mountain Dew	NA	803,864,92x.x1

NA = Not Applicable  
Part numbers subject to change without notice.

# PARTS LIST

## SCREWS & NUTS

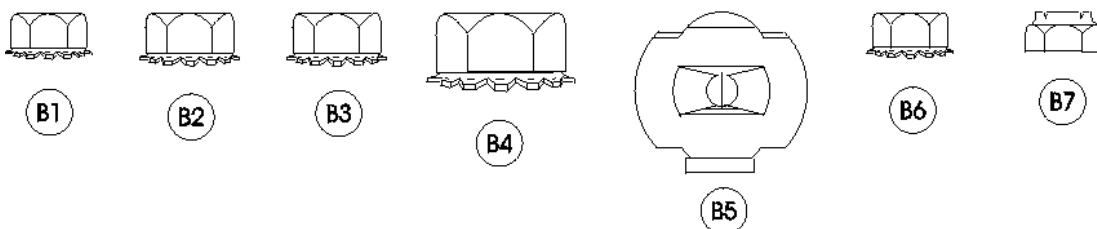
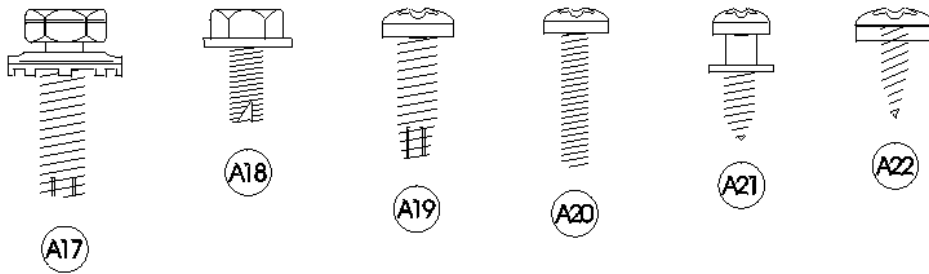
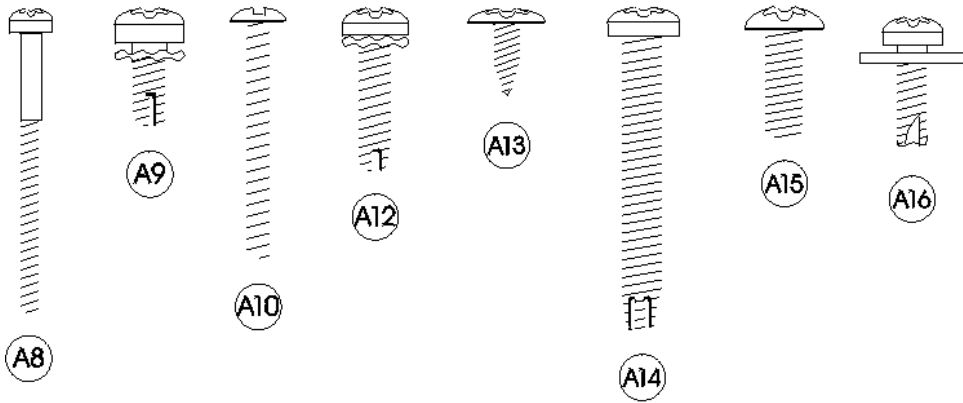
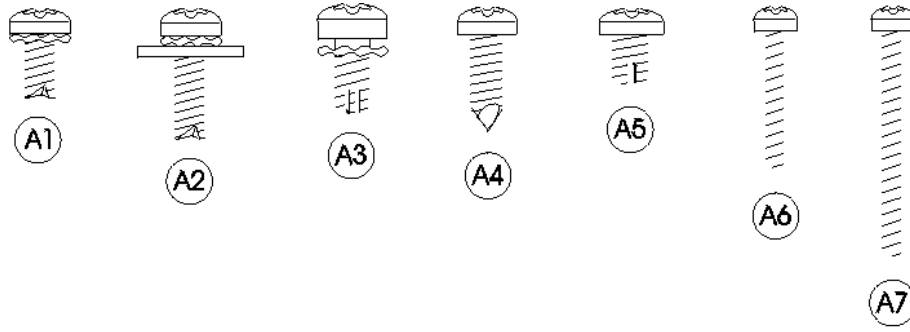

NA = Not Applicable  
Part numbers subject to change without notice.

## PARTS LIST

### SCREWS & NUTS

ITEM	PART NUMBER	PART NAME AND DESCRIPTION
A1	900,301,70x.x1	Screw, Phil Pan Swage Form #6 - 32 x 3/8"
A2	900,301,64x.x1	Screw, Phil Pan Swage Form w/washer #8 - 32 x 1/2"
A3	900,301,83x.x1	Screw, Phil Pan Swage Form #10 - 32 x 5/16"
A4	900,301,50x.x1	Screw, Phil Pan w/out washer, #8 - 18 x 1/2"
A5	900,301,97x.x1	Screw, Phil Pan Swage Form #8 - 32 x 1/4"
A6	900,300,47x.x1	Screw, Vend Motor, #4-24 x 3/4" Single Switch (NOT USED)
A7	900,301,82x.x1	Screw, Vend Motor, #4-24 x 1 1/16" Double Switch (NOT USED)
A8	900,301,61x.x1	Screw, Vend Motor, #4-24 x 1 1/2" Triple Switch (NOT USED)
A9	900,301,56x.x1	Screw, Phil Pan Cutting #8 - 32 x 3/8"
A10	900,201,31x.x1	Screw, Machine, #6 - 32 x 1 1/4"
A11	900,301,97x.x1	Screw, Phil Pan Sems #8 - 32 x 1/4"
A12	900,301,85x.x1	Screw, Phil Thread Form #8 - 32 x 5/8"
A13	900,300,16x.x1	Screw, Phil Head Truss #6 x 3/8"
A14	900,301,81x.x1	Screw, Phil Pan Form #10 - 32 x 1 1/4"
A15	900,201,14x.x1	Screw, Machine Truss, #10 - 32 x 1/2"
A16	900,301,65x.x1	Screw, Phil Pan Sems with washer, #8 - 18 x 1/2"
A17	900,302,01x.x1	Screw, Self Tapping, 1/4 - 20 x 5/8"
A18	900,301,69x.x1	Screw, Hex Head Swage Form #8 - 36 x 3/8"
A19	900,901,51x.x1	Screw, Phil Pan Tapping #10 - 32 x 5/8"
A20	900,201,22x.x1	Screw, Machine Phil Pan #8 - 32 x 3/4"
A21	900,301,98x.x1	Screw, Phil Pan Shoulder #8 - 18 x 1/2"
A22	900,301,84x.x1	Screw, Phil Pan #8-18x1/2"
A23	900,500,26x.x1	Shoulder Screw 1/2" Long
A24	900,201,13x.x1	Screw, Hex Head
A25	900,301,73x.x1	Screw, Tap 1/4-20x1" Type F
A26	800,303,15x.x1	Screw, Phil Pan #8-18x3/4"
A27	800,303,18x.x1	Screw, Truss Type 23 #8-32x1/2
A28	900,301,94x.x1	Screw, Phil Flat 23B #10-32x1/2"
A29	900,201,44x.x1	Screw, Machine Brass #6-32x1/4"
A30	900,301,99x.x1	Screw, Plastic 8-hi/low x 1 1/4
A31	900,301,55x.x1	Screw, Phil Pan Swage Form #8-32x1/2"
A32	900,303,08x.x1	Screw, Hex Washer Type 1 #8-32x3/8"
A34	800,303,22x.x1	Screw, Phil Pan #6-20x3/8
A35	900,302,02x.x1	Screw, Self Tapping, #8-18x3/4
A36	900,201,86x.x1	Screw, Phil Pan Head #6-32x1/4"
B1	900,800,65x.x1	Keps Nut, #10 - 32
B2	900,800,67x.x1	Keps Nut, 1/4 - 20
B3	900,800,50x.x1	Keps Nut, #8 - 32
B4	900,800,69x.x1	Keps Nut, Top Door Hinge, 3/8 - 16
B5	900,800,85x.x1	Speed Nut
B6	900,800,49x.x1	Keps Nut, #6 - 32
B7	900,800,51x.x1	Elastic Stop Nut, #8 - 32
B8	900,800,81x.x1	Hex Nut 8-32
B9	900,902,37x.x1	Push Nut, Acorn Type
B10	900,801,02x.x1	Hex Nut 5/16-18
B11	900,800,81x.x1	Hex Nut, Flange with Serrations 8-32

NA = Not Applicable  
 Part numbers subject to change without notice.

**PARTS LIST**

**WASHERS, BOLTS, & MISC. HARDWARE**

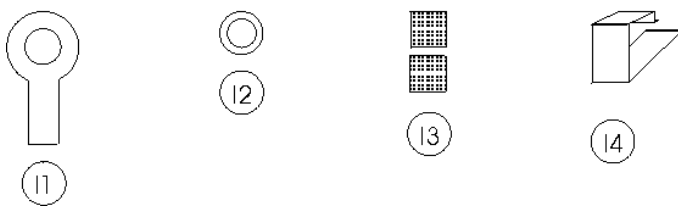
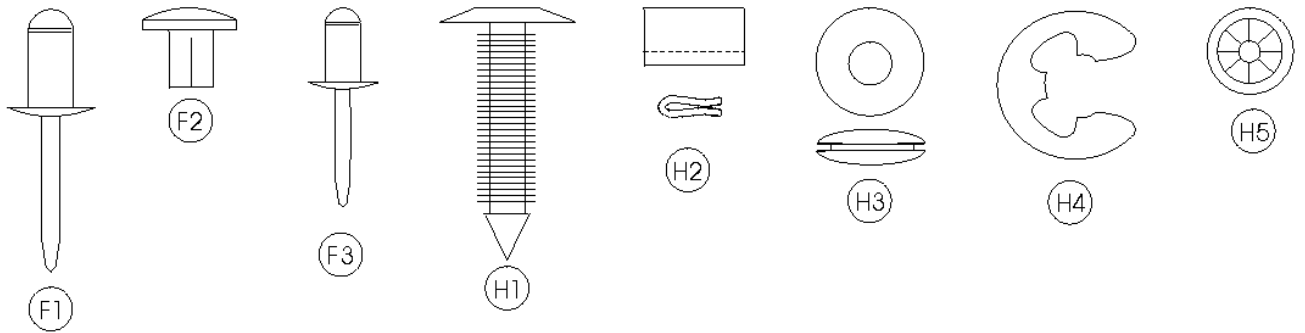
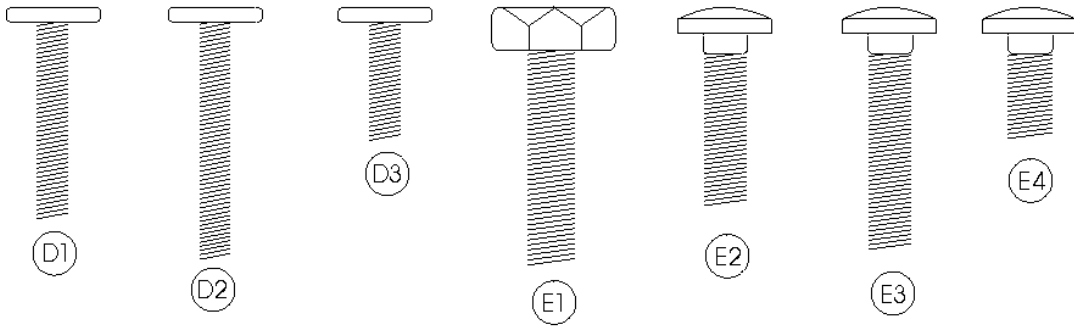
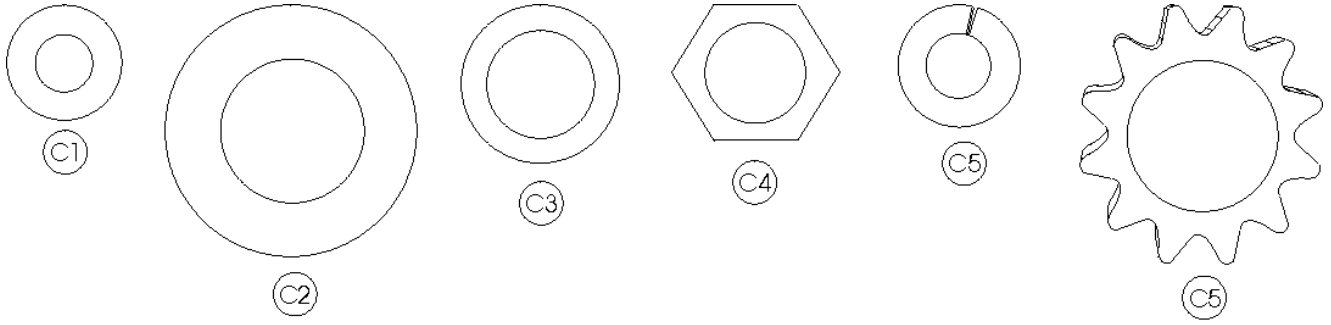

**PARTS LIST**

**WASHERS, BOLTS, & MISC. HARDWARE**

ITEM	PART NUMBER	PART NAME AND DESCRIPTION
C1	900,700,60x.x1	Washer, Delrin .047 Thick 3/8"IDx5/8"OD
C2	901,303,77x.x1	Washer, Door Hinge
C3	901,503,06x.x1	Washer, Flat #2949 (T-Handle)
C4	901,503,08x.x1	Washer, Hex #29-34 (T-Handle)
C5	900,700,36x.x1	Lockwasher, Split 3/8"
C6	900,700,89x.x1	Lockwasher, Shakeproof 5/8" (1132-00-00-0551)
C7	900,700,02x.x1	Steel Washer, 18 Gauge (1/2"x3/16")
C8	900,700,62x.x1	Washer, Shakeproof (4610-16-01-0551)
C10	900,700,83x.x1	Washer, Flat 18 Gauge (17/64"IDx5/8"OD)
C11	900,700,08x.x1	Washer, Flat 14 Gauge (5/16"-3/8"x7/8")
C12	801,902,48x.x1	Nylon Spacer
	900,701,05x.x1	Washer Flat (.343"ID x .688" OD .6T)
D1	900,400,43x.x1	T-Bolt, #8 - 32 x 1" (obsolete)
D2	900,400,41x.x1	T-Bolt, #8 - 32 x 1 3/8"
D3	900,40x.x5x.x1	T-Bolt, #8 - 32 x 3/4"
D4	900,400,45x.x1	T-Bolt, #8 - 32 x 1/2"
E1	900,400,44x.x1	Refrigeration Bolt, 3/8 - 16 x 1"
E2	900,201,17x.x1	Carriage Bolt, 1/4 - 20 x 1"
E3	900,201,23x.x1	Carriage Bolt, 1/4 - 20 x 1 1/4"
E4	900,201,45x.x1	Carriage Bolt, 1/4 - 20 x 1/2"
E5	900,201,54x.x1	Carriage Bolt, 1/4 - 20 x 3/8"
E6	900,201,56x.x1	Carriage Bolt, 1/4 - 20 x 3/4"
E7	900,303,12x.x1	Carriage Bolt, 1/4-20x5/8" (obsolete)
E8	900,201,85x.x1	Carriage Bolt, 5/16x18x1 1/4" Top Hinge (drop in)
E9	800,303,19x.x1	Carriage Bolt, 1/4-20x5/8"
E10	900,202,04x.x1	Carriage Bolt, 1/4-20x1/2" (red)
F1	901,100,43x.x1	Pop Rivet, Aluminum 1/4"
F2	901,100,44x.x1	Drive Rivet, #38-108-06-13 1/4" dia.
F4	901,100,54x.x1	Pop Rivet, Black 1/8"
F5	901,100,61x.x1	Pop Rivet, Steel (Zinc Plated) 1/8"
F6	901,100,53x.x1	Pop Rivet, Aluminum 1/8"
F7	901,100,60x.x1	Pop Rivet, Steel (Zinc Plated) 3/16"
H1	900,902,13x.x1	Christmas Tree Clip #354280307-00 (NOT USED)
H2	900,901,89x.x1	Tinnerman Clip, Fan Shroud (C5207-014-3B)
H3	900,401,09x.x1	Grommet, Bk. Rubber #97
H4	901,503,07x.x1	E-Ring #31-30
H5	900,900,90x.x1	Retainer, Roller Pin
H6	900,902,18x.x1	Tinnerman Clip
H7	801,807,01x.x1	Hole Plug, Snap in - 1 1/4
H8	901,806,77x.x1	Grommet, Admiral #B53351
H9	902,100,29x.x1	Silencer
I1	804,601,45x.x1	#6 Terminal Ring Crimp 16-14 AWG
I2	801,902,48x.x1	Nylon Spacer used on Coke D/O Boards
I3	801,809,12x.x1	Velcro Blocks
I4	801,807,49x.x1	Vender Defender Clamp



## PARTS LIST

### WASHERS, BOLTS, & MISC. HARDWARE

ITEM	PART NUMBER	PART NAME AND DESCRIPTION
I5	901,901,89x.x1	Clamp, Cable 1" Heyco 3390
I6	900,901,79x.x1	Clamp, Nylon 5/16" Black Heyco 3355 or Dennison 10159
I7	900,901,80x.x1	Clamp, Nylon 1/2" Heyco 3328
I8	901,901,06x.x1	Hand Tie, x.x"
I9	901,902,01x.x1	Wire Tie, 7 1/2"
I10	901,901,00x.x1	Wire Ties, 4"
I11	901,900,55x.x1	Clamp, Nylon 3/4" Heyco 3382BL
I12	901,902,83x.x1	Cable Tie, x.x"
I13	900,902,14x.x1	Canoe Clip #254-090-301-00-0108

### ELECTRONICS & COMPONENTS

ITEM	PART NAME AND DESCRIPTION	HT2 (501E)	HT3 (501E)
1	Electronic Lock Assembly	805,202,44x.x1	805,202,44x.x1
2	Electronic Lock Light Pipe	801,814,19x.x1	801,814,19x.x1
3	Machine Controller	804,918,15x.x1	NA
4	Machine Controller Base	801,813,45x.x1	NA
5	Machine Controller Cover	631,000,68x.x3	NA
6	Universal Controller	804,916,31x.x1	NA
7	Display (Vacuum Fluorescent)	804,918,69x.x1	804,918,69x.x1
8	Transformer	804,909,80x.x1	804,909,80x.x1
9	Machine Controller EPROM	804,917,61x.x1	NA
10	Universal Controller EPROM	804,916,25x.x1	NA
11	Fuse 6 Amp (F2)	804,910,93x.x1	804,910,93x.x1
12	Fuse 1.6 Amp (F1)	804,800,71x.x1	804,800,71x.x1
13	Control Board Assy. HT3	NA	631,053,30x.x3
14	HT3 Eprom Control Board	NA	804,919,24x.x1

NA = Not Applicable  
 Part numbers subject to change without notice.